

## Low voltage fast-switching PNP power transistors

### Features

- Very low collector-emitter saturation voltage
- High current gain characteristic
- Fast switching speed

### Applications

- LED
- Motherboard & hard disk drive
- Mobile equipment
- DC-DC converter

### Description

The devices are PNP transistors manufactured using new "PB-HDC" (power bipolar high density current) technology. The resulting transistor shows exceptional high gain performances coupled with very low saturation voltage.

The 2STF2340 complementary PNP is the 2STF1340.

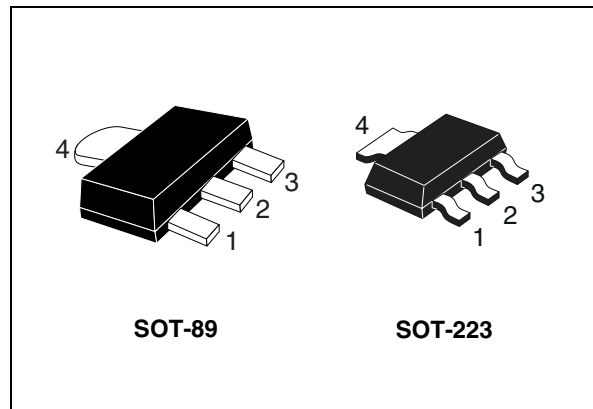

Figure 1. Internal schematic diagram

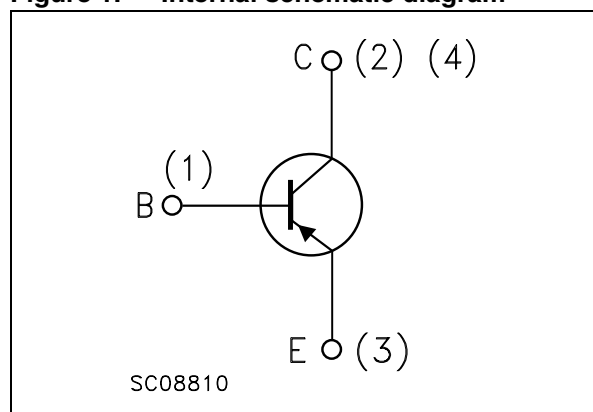

Table 1. Device summary

Order codes	Marking	Packages	Packaging
2STF2340	2340	SOT-89	Tape and reel
2STN2340	N2340	SOT-223	Tape and reel

# 1 Electrical ratings

**Table 2. Absolute maximum rating**

Symbol	Parameter	Value		Unit
		2STF2340	2STN2340	
		SOT-89	SOT-223	
$V_{CES}$	Collector-emitter voltage ( $V_{BE} = 0$ )	-40		V
$V_{CEO}$	Collector-emitter voltage ( $I_B = 0$ )	-40		V
$V_{EBO}$	Emitter-base voltage ( $I_C = 0$ )	-5		V
$I_C$	Collector current	-3		A
$I_{CM}$	Collector peak current ( $t_p < 5$ ms)	-6		A
$P_{TOT}$	Total dissipation at $T_{amb} = 25$ °C	1.4	1.6	W
$T_{STG}$	Storage temperature	-65 to 150		°C
$T_J$	Max. operating junction temperature	150		°C

**Table 3. Thermal data**

Symbol	Parameter	SOT-89	SOT-223	Unit
$R_{thJA}^{(1)}$	Thermal resistance junction-ambient max	89	78	°C/W

1. Device mounted on PCB area of 1 cm<sup>2</sup>

## 2 Electrical characteristics

$T_{\text{case}} = 25\text{ }^{\circ}\text{C}$  unless otherwise specified

**Table 4. Electrical characteristics**

Symbol	Parameter	Test conditions	Min.	Typ.	Max.	Unit
$I_{\text{CBO}}$	Collector cut-off current ( $I_{\text{E}} = 0$ )	$V_{\text{CB}} = -40\text{ V}$			-0.1	$\mu\text{A}$
$I_{\text{EBO}}$	Emitter cut-off current ( $I_{\text{C}} = 0$ )	$V_{\text{EB}} = -5\text{ V}$			-0.1	$\mu\text{A}$
$V_{(\text{BR})\text{CBO}}^{(1)}$	Collector-base breakdown voltage ( $I_{\text{E}} = 0$ )	$I_{\text{C}} = -100\text{ }\mu\text{A}$	-40			V
$V_{(\text{BR})\text{CEO}}^{(1)}$	Collector-emitter breakdown voltage ( $I_{\text{B}} = 0$ )	$I_{\text{C}} = -10\text{ mA}$	-40			V
$V_{(\text{BR})\text{EBO}}$	Emitter-base breakdown voltage ( $I_{\text{C}} = 0$ )	$I_{\text{E}} = -100\text{ }\mu\text{A}$	-5			V
$V_{\text{CE(sat)}}^{(1)}$	Collector-emitter saturation voltage	$I_{\text{C}} = -2\text{ A}$ $I_{\text{B}} = -100\text{ mA}$ $I_{\text{C}} = -3\text{ A}$ $I_{\text{B}} = -150\text{ mA}$			-250 -350	mV mV
$V_{\text{BE(sat)}}^{(1)}$	Base-emitter saturation voltage	$I_{\text{C}} = -2\text{ A}$ $I_{\text{B}} = -100\text{ mA}$			-1.2	V
$h_{\text{FE}}^{(1)}$	DC current gain	$I_{\text{C}} = -0.1\text{ A}$ $V_{\text{CE}} = -2\text{ V}$ $I_{\text{C}} = -1\text{ A}$ $V_{\text{CE}} = -2\text{ V}$ $I_{\text{C}} = -3\text{ A}$ $V_{\text{CE}} = -2\text{ V}$	100 180	220	450	
$f_{\text{t}}$	Transition frequency	$I_{\text{C}} = -0.1\text{ A}$ $V_{\text{CE}} = -5\text{ V}$ $f = 100\text{ MHz}$	100			MHz
$C_{\text{CBO}}$	Collector-base capacitance ( $I_{\text{E}} = 0$ )	$V_{\text{CB}} = -10\text{ V}$ $f = 1\text{ MHz}$		50		pF
$t_{\text{on}}$ $t_{\text{off}}$	Resistive load Turn-on time Turn-off time	$I_{\text{C}} = -1.5\text{ A}$ $V_{\text{CC}} = -10\text{ V}$ $I_{\text{B(on)}} = -I_{\text{B(off)}} = -150\text{ mA}$ $V_{\text{BB(off)}} = 5\text{ V}$		80 450		ns ns

1. Pulse test: pulse duration  $\leq 300\text{ }\mu\text{s}$ , duty cycle  $\leq 2\%$

## 2.1 Electrical characteristics (curves)

Figure 2. Output characteristics

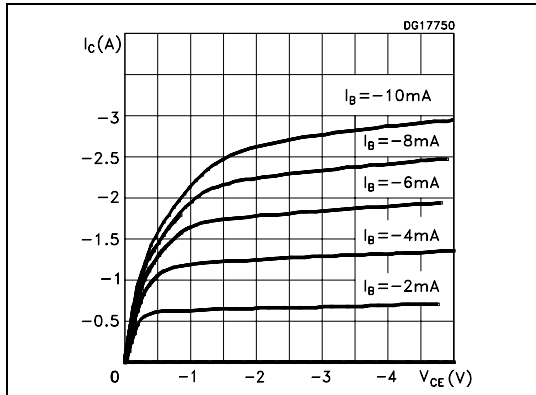

Figure 3. Derating curve

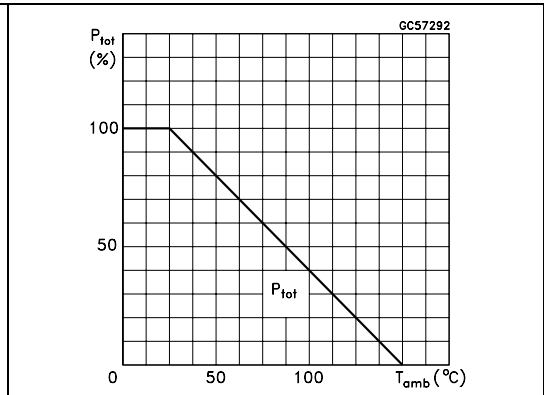

Figure 4. DC current gain ( $V_{CE} = -2 V$ )

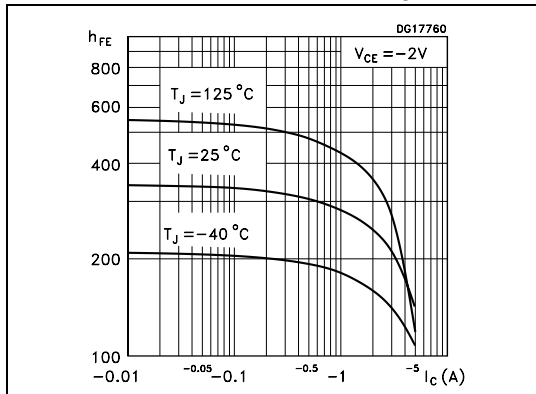

Figure 5. DC current gain ( $V_{CE} = -5 V$ )

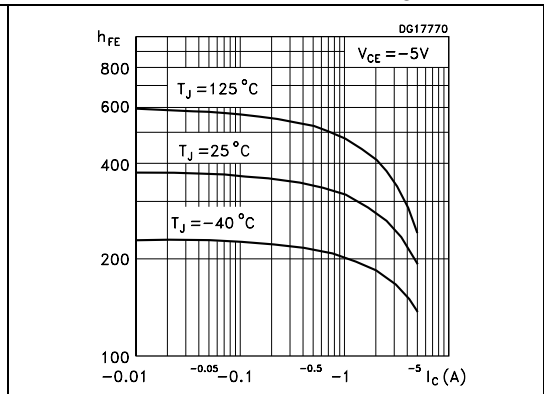

Figure 6. Collector-emitter saturation voltage

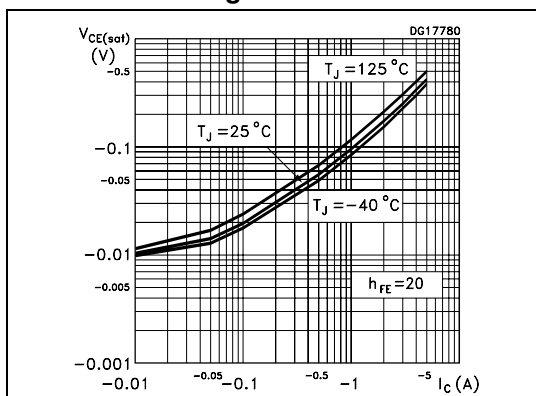

Figure 7. Base-emitter saturation voltage

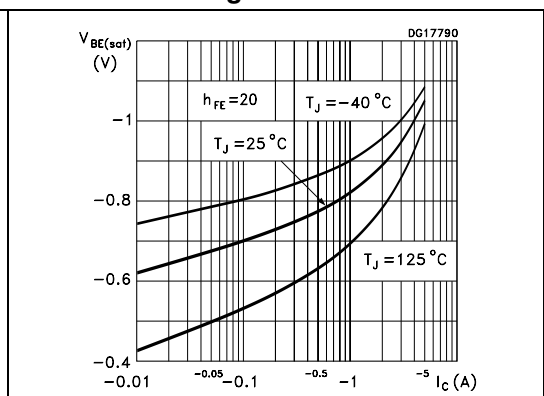

Figure 8. Resistive load switching on

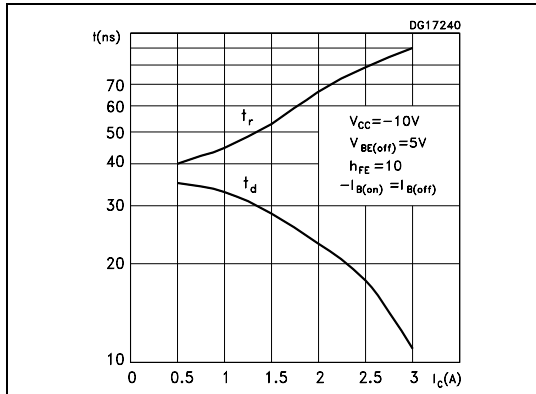

Figure 9. Resistive load switching off

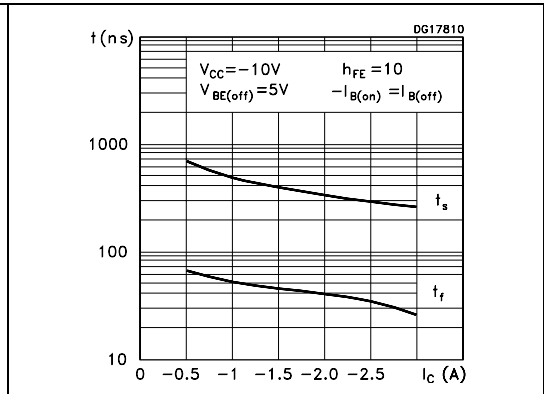
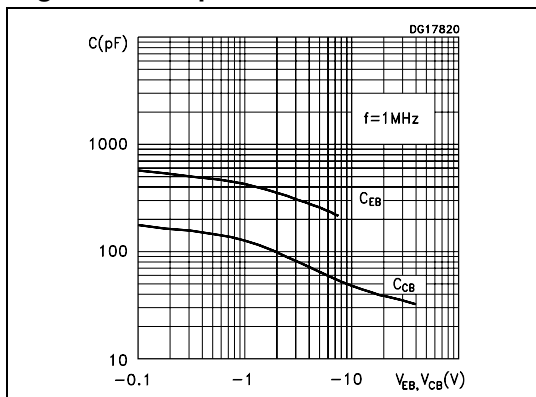
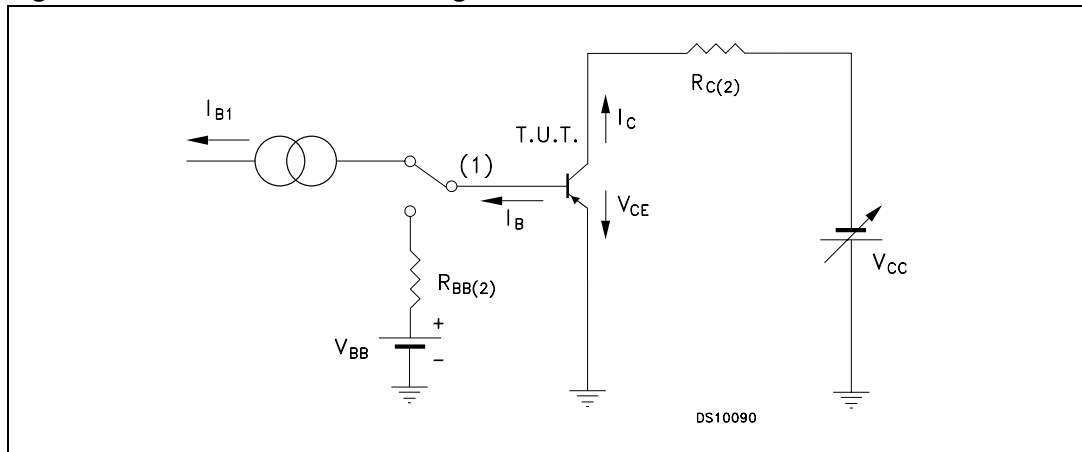

Figure 10. Capacitance curves



## 2.2 Test circuits

Figure 11. Resistive load switching test circuit



1. Fast electronic switch
2. Non-inductive resistor

### 3 Package mechanical data

In order to meet environmental requirements, ST offers these devices in different grades of ECOPACK<sup>®</sup> packages, depending on their level of environmental compliance. ECOPACK<sup>®</sup> specifications, grade definitions and product status are available at: [www.st.com](http://www.st.com). ECOPACK<sup>®</sup> is an ST trademark.

## SOT-89 mechanical data

Dim.	mm		
	Min.	Typ.	Max.
A	1.40		1.60
B	0.44		0.56
B1	0.36		0.48
C	0.35		0.44
C1	0.35		0.44
D	4.40		4.60
D1	1.62		1.83
E	2.29		2.60
e	1.42		1.57
e1	2.92		3.07
H	3.94		4.25
K	1°		8°
L	0.89		1.20
R		0.25	

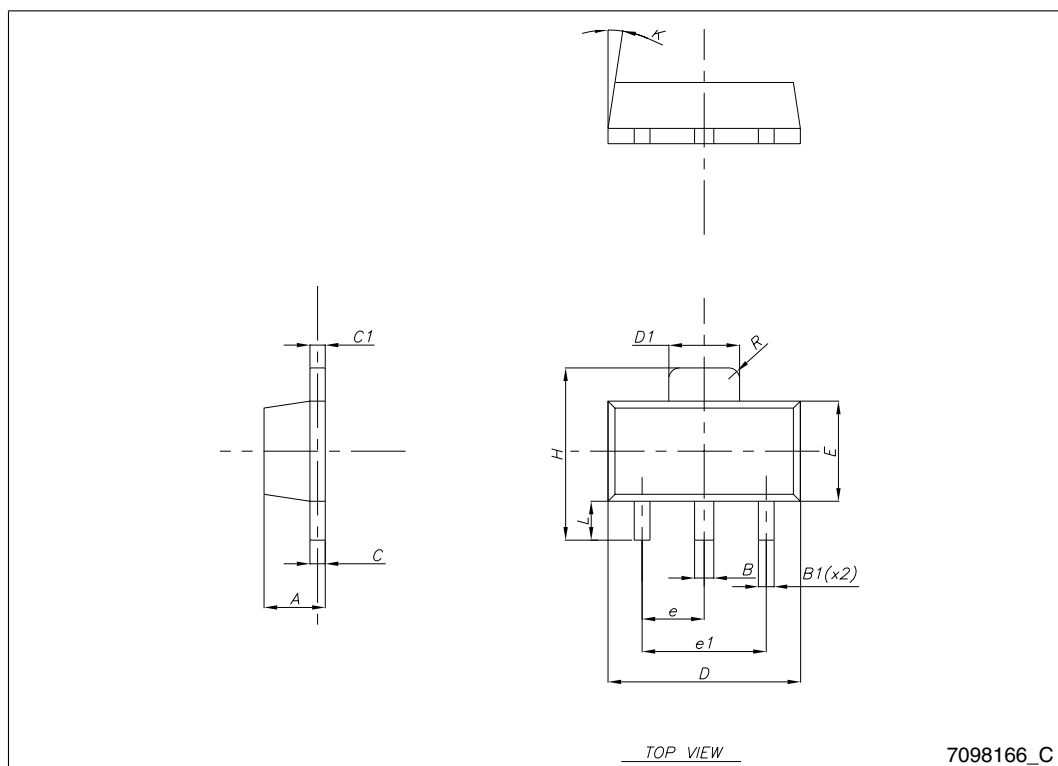

**SOT-223 mechanical data**

DIM.	mm.		
	min.	typ	max.
A			1.80
A1	0.02		0.1
B	0.60	0.70	0.85
B1	2.90	3.00	3.15
c	0.24	0.26	0.35
D	6.30	6.50	6.70
e		2.30	
e1		4.60	
E	3.30	3.50	3.70
H	6.70	7.00	7.30
V			10°

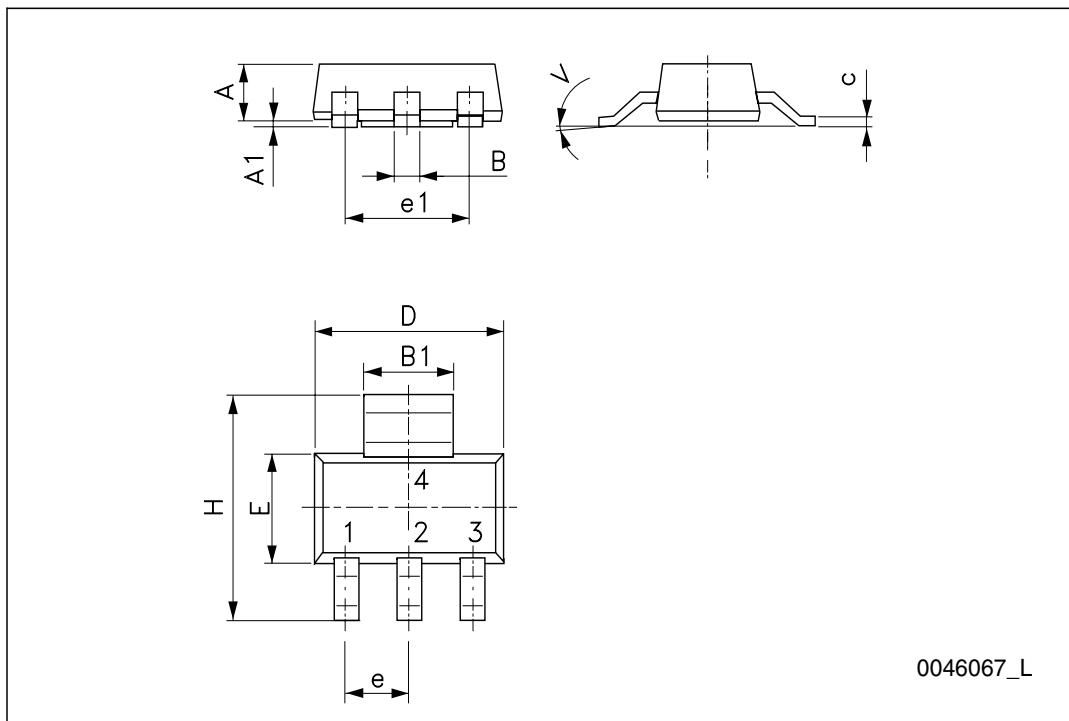

0046067\_L



## 4 Revision history

**Table 5. Document revision history**

Date	Revision	Changes
04-Dec-2007	1	Initial release.
19-Oct-2009	2	Inserted 2STN2340 in SOT-223 package.

**Please Read Carefully:**

Information in this document is provided solely in connection with ST products. STMicroelectronics NV and its subsidiaries ("ST") reserve the right to make changes, corrections, modifications or improvements, to this document, and the products and services described herein at any time, without notice.

All ST products are sold pursuant to ST's terms and conditions of sale.

Purchasers are solely responsible for the choice, selection and use of the ST products and services described herein, and ST assumes no liability whatsoever relating to the choice, selection or use of the ST products and services described herein.

No license, express or implied, by estoppel or otherwise, to any intellectual property rights is granted under this document. If any part of this document refers to any third party products or services it shall not be deemed a license grant by ST for the use of such third party products or services, or any intellectual property contained therein or considered as a warranty covering the use in any manner whatsoever of such third party products or services or any intellectual property contained therein.

**UNLESS OTHERWISE SET FORTH IN ST'S TERMS AND CONDITIONS OF SALE ST DISCLAIMS ANY EXPRESS OR IMPLIED WARRANTY WITH RESPECT TO THE USE AND/OR SALE OF ST PRODUCTS INCLUDING WITHOUT LIMITATION IMPLIED WARRANTIES OF MERCHANTABILITY, FITNESS FOR A PARTICULAR PURPOSE (AND THEIR EQUIVALENTS UNDER THE LAWS OF ANY JURISDICTION), OR INFRINGEMENT OF ANY PATENT, COPYRIGHT OR OTHER INTELLECTUAL PROPERTY RIGHT.**

**UNLESS EXPRESSLY APPROVED IN WRITING BY AN AUTHORIZED ST REPRESENTATIVE, ST PRODUCTS ARE NOT RECOMMENDED, AUTHORIZED OR WARRANTED FOR USE IN MILITARY, AIR CRAFT, SPACE, LIFE SAVING, OR LIFE SUSTAINING APPLICATIONS, NOR IN PRODUCTS OR SYSTEMS WHERE FAILURE OR MALFUNCTION MAY RESULT IN PERSONAL INJURY, DEATH, OR SEVERE PROPERTY OR ENVIRONMENTAL DAMAGE. ST PRODUCTS WHICH ARE NOT SPECIFIED AS "AUTOMOTIVE GRADE" MAY ONLY BE USED IN AUTOMOTIVE APPLICATIONS AT USER'S OWN RISK.**

Resale of ST products with provisions different from the statements and/or technical features set forth in this document shall immediately void any warranty granted by ST for the ST product or service described herein and shall not create or extend in any manner whatsoever, any liability of ST.

ST and the ST logo are trademarks or registered trademarks of ST in various countries.

Information in this document supersedes and replaces all information previously supplied.

The ST logo is a registered trademark of STMicroelectronics. All other names are the property of their respective owners.

© 2009 STMicroelectronics - All rights reserved

STMicroelectronics group of companies

Australia - Belgium - Brazil - Canada - China - Czech Republic - Finland - France - Germany - Hong Kong - India - Israel - Italy - Japan - Malaysia - Malta - Morocco - Philippines - Singapore - Spain - Sweden - Switzerland - United Kingdom - United States of America

[www.st.com](http://www.st.com)