

Specification

Quad Small Form-factor Pluggable Plus (QSFP/QSFP+) Product



T Q S - Q 1 L H 8 - X C A x x

Distance

Model Name	Voltage	Category	Device type	Interface	LOS	Temperature
TQS-Q1LH8-XCAxx	3.3V	With DDMI	VCSEL/PIN	CML/CML	LVTTL	0°C~ +70°C

Purpose

This document validates solely for the product of Formerica OptoElectronics Inc., 40-Gbps+ Active Optical Cable (AOC). However, this document is not fully complete yet, therefore, this datasheet only provides basic information and electronic characteristics. This document is for customer's reference only, and it subjects to change without notice.

Description

Formerica OptoElectronics Inc. Quad Small Form-factor Pluggable Plus (QSFP+) active optical cable (AOC) is a new high speed pluggable I/O interface products. This interconnecting system offers 4 channels and maximum bandwidth of 40Gbps which are based on the proprietary technique Silicon Optical Bench (SiOB) as an optical engine. This module provides high performance and excellent efficiency in the optical communication.

Features

- Four channel full-duplex AOC (Electrical Interface Only)
- Compliant to SFF-8436 QSFP+ Specification Revision 4.0
- QSFP footprint (Quad small form-factor, pluggable)
- Supports 40 Gbps data rate links of up to 150 m
- Low power consumption of max 1.5 W Power Level 1 compliance
- Hot pluggable electrical interface
- 0 to 70°C case temperature operating range
- RoHS-6 Compliant (lead-free)

Applications

- 40GBASE-SR4 Ethernet links
- Infiniband QDR and DDR interconnects
- 4G/8G/10G Fiber Channel
- SATA/SAS Storage
- HPC Interconnects
- Client-side 40G Telecom connections

Absolute Maximum Rating

Not necessarily applied together. Exceeding these values may cause permanent damage. Functional operation under these conditions is not implied.

Parameter	Symbol	Min	Typical	Max	Unit	Note
Storage Temperature	Ts	-40		100	°C	
3.3V Power Supply Voltage	Vcc	-0.5		3.6	V	
Data Input Voltage-Single Ended		-0.5		V _{cc} + 0.5	V	
Data Input Voltage-Single Ended	VDIP - VDIN			1.0	V	
Relative Humidity	RH	5		85	%	

Recommended Operatin Conditions

Parameter	Symbol	Min	Typical	Max	Unit	Note
Case Temperature	Tc	0	40	70	°C	
3.3 V Power Supply Voltage	Vcc	3.135	3.3	3.465	V	
Signal Rate per Channel		2.5		10.3125	GB/s	
Control* Input Voltage High	Vih	2		V _{cc} + 3	V	
Control* Input Voltage Low	Vil	-0.3		0.8	V	
Two Wire Serial (TWS) Interface Clock Rate				400	kHz	
Receiver Differential Data Output Load			100		Ohms	
Standard Cable Lengths		3		150	m	1

Notes:

1. Different cable lengths will be recommended to choose OM2, OM3, and OM4 to meet the effective modal bandwidth requirements per “OM” designations (per ISO/IEC 11801.)

Transceiver Electrical Characteristics

The following characteristics are defined over the Recommended Operating Conditions unless otherwise noted. Typical values are for $T_c = 40^\circ\text{C}$, $V_{cc} = 3.3\text{ V}$.

Parameter	Symbol	Min	Typical	Max	Unit	Note
10G Transceiver Power Consumption				1.5	W	
Transceiver Power Supply Current				420	mA	
Transceiver Power Initialization Time	tpwr init			2000	ms	1

Notes:

1. "Initialization Time" is the time from when the supply voltages reach and remain above the minimum "Recommended Operating Conditions" to the time when the module enables TWS access. The module at that point is fully functional.

Electrical Characteristics

Parameter	Symbol	Min	Typical	Max	Unit	Note
Transmitter Electrical Characteristics						
Data Input Differential Peak-to-Peak Voltage Swing		175		1600	mVpp	
LOS Assert Threshold: Tx Data Input Differential Peak-to-Peak Voltage Swing	ΔDI_{PP} LOS	50			mVpp	
Differential input threshold			50		mV	
Receiver Electrical Characteristics						
Data Output Differential Peak-to-Peak Voltage Swing (AC-Coupled)	ΔVDO_{pp}	200		900	mVpp	
Output transition time 20% to 80%	t _{rise,t_{fall}}	28			ps	
Output Total Jitter				62	ps	
BER Ratio	BER			10^{-12}		1

Notes:

1. Testing pattern with PRBS $2^{31}-1$.

Recommended Host Board POWER Supply Circuit

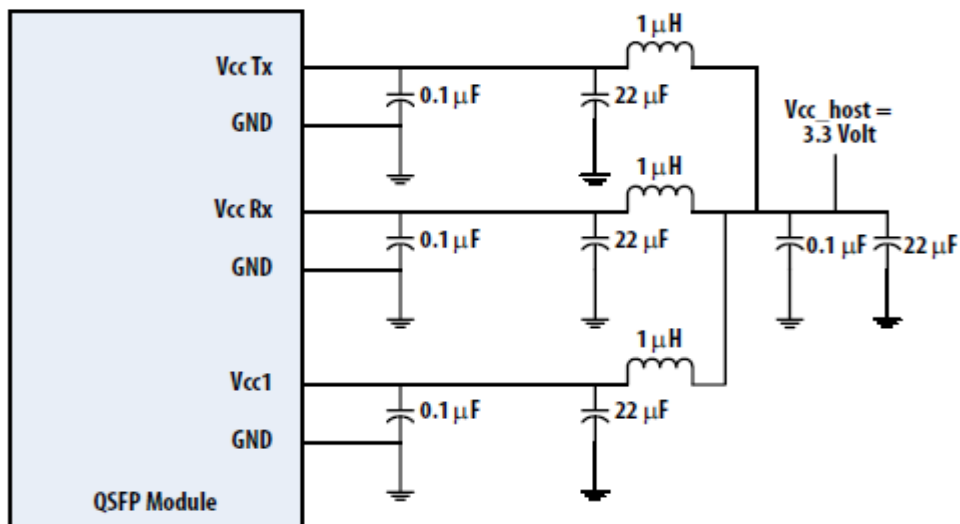

QSFP+ Module Pad Assignments and Descriptions

38	GND	████████████████████
37	TX1n	██████████████████
36	TX1p	██████████████████
35	GND	████████████████████
34	TX3n	██████████████████
33	TX3p	██████████████████
32	GND	████████████████████
31	LPMODE	██████████████████
30	Vcc1	██████████████████
29	VccTx	██████████████████
28	IntL	██████████████████
27	ModPrsL	██████████████████
26	GND	████████████████████
25	RX4p	██████████████████
24	Rx4n	██████████████████
23	GND	████████████████████
22	RX2p	██████████████████
21	RX2n	██████████████████
20	GND	████████████████████

Top Side
Viewed From Top

Module Card Edge

████████████████████	GND	1
██████████████████	TX2n	2
██████████████████	TX2p	3
████████████████████	GND	4
██████████████████	TX4n	5
██████████████████	TX4p	6
████████████████████	GND	7
██████████████████	Modsell	8
██████████████████	ResetL	9
██████████████████	VccRx	10
██████████████████	SCL	11
██████████████████	SDA	12
████████████████████	GND	13
██████████████████	RX3p	14
██████████████████	Rx3n	15
████████████████████	GND	16
██████████████████	RX1p	17
██████████████████	RX1n	18
████████████████████	GND	19

Bottom Side
Viewed From Bottom

Pin	Logic	Symbol	Description	Plug Sequence	Notes
1		GND	Ground	1	1
2	CML-I	Tx2n	Transmitter Inverted Data Input	3	
3	CML-I	Tx2p	Transmitter Non-Inverted Data Input	3	
4		GND	Ground	1	1
5	CML-I	Tx4n	Transmitter Inverted Data Input	3	
6	CML-I	Tx4p	Transmitter Non-Inverted Data Input	3	
7		GND	Ground	1	1
8	LVTTL-I	ModSelL	Module Select	3	
9	LVTTL-I	ResetL	Module Reset	3	
10		Vcc Rx	+ 3.3V Power Supply Receiver	2	2
11	LVC MOS-I/O	SCL	2-wire serial interface clock	3	
12	LVC MOS-I/O	SDA	2-wire serial interface data	3	
13		GND	Ground	1	2
14	CML-O	Rx3p	Receiver Non-Inverted Data Output	3	
15	CML-O	Rx3n	Receiver Inverted Data Output	3	
16		GND	Ground	1	1
17	CML-O	Rx1p	Receiver Non-Inverted Data Output	3	
18	CML-O	Rx1n	Receiver Inverted Data Output	3	

Pin	Logic	Symbol	Description	Plug Sequence	Notes
19		GND	Ground	1	1
20		GND	Ground	1	1
21	CML-O	Rx2n	Receiver Inverted Data Output	3	
22	CML-O	Rx2p	Receiver Non-Inverted Data Output	3	
23		GND	Ground	1	1
24	CML-O	Rx4n	Receiver Inverted Data Output	3	
25	CML-O	Rx4p	Receiver Non-Inverted Data Output	3	
26		GND	Ground	1	1
27	LVTTL-O	ModPrsL	Module Present	3	
28	LVTTL-O	IntL	Interrupt	3	
29		Vcc Tx	+ 3.3V Power supply transmitter	2	2
30		Vcc1	+ 3.3V Power supply	2	2
31	LVTTL-I	LPMODE	Low Power Mode	3	
32		GND	Ground	1	1
33	CML-I	Tx3p	Transmitter Non-Inverted Data Input	3	
34	CML-I	Tx3n	Transmitter Inverted Data Input	3	
35		GND	Ground	1	1
36	CML-I	Tx1p	Transmitter Non-Inverted Data Input	3	
37	CML-I	Tx1n	Transmitter Inverted Data Input	3	
38		GND	Ground	1	1

Note 1: GND is the symbol for signal and supply (power) common for the QSFP module. All are common within the QSFP+ module and all module voltages are referenced to this potential unless otherwise noted. Connect these directly to the host board signal-common ground plane.

Note 2: Vcc Rx, Vcc1 and Vcc Tx are the receiver and transmitter power supplies and shall be applied concurrently. Requirements defined for the host side of the Host Edge Card Connector are listed in Table. Recommended host board power supply filtering is shown in Host board power supply circuit. Vcc Rx Vcc1 and Vcc Tx may be internally connected within the QSFP+ module in any combination. The connector pins are each rated for a maximum current of 500 mA.

Recommended Interface Circuit

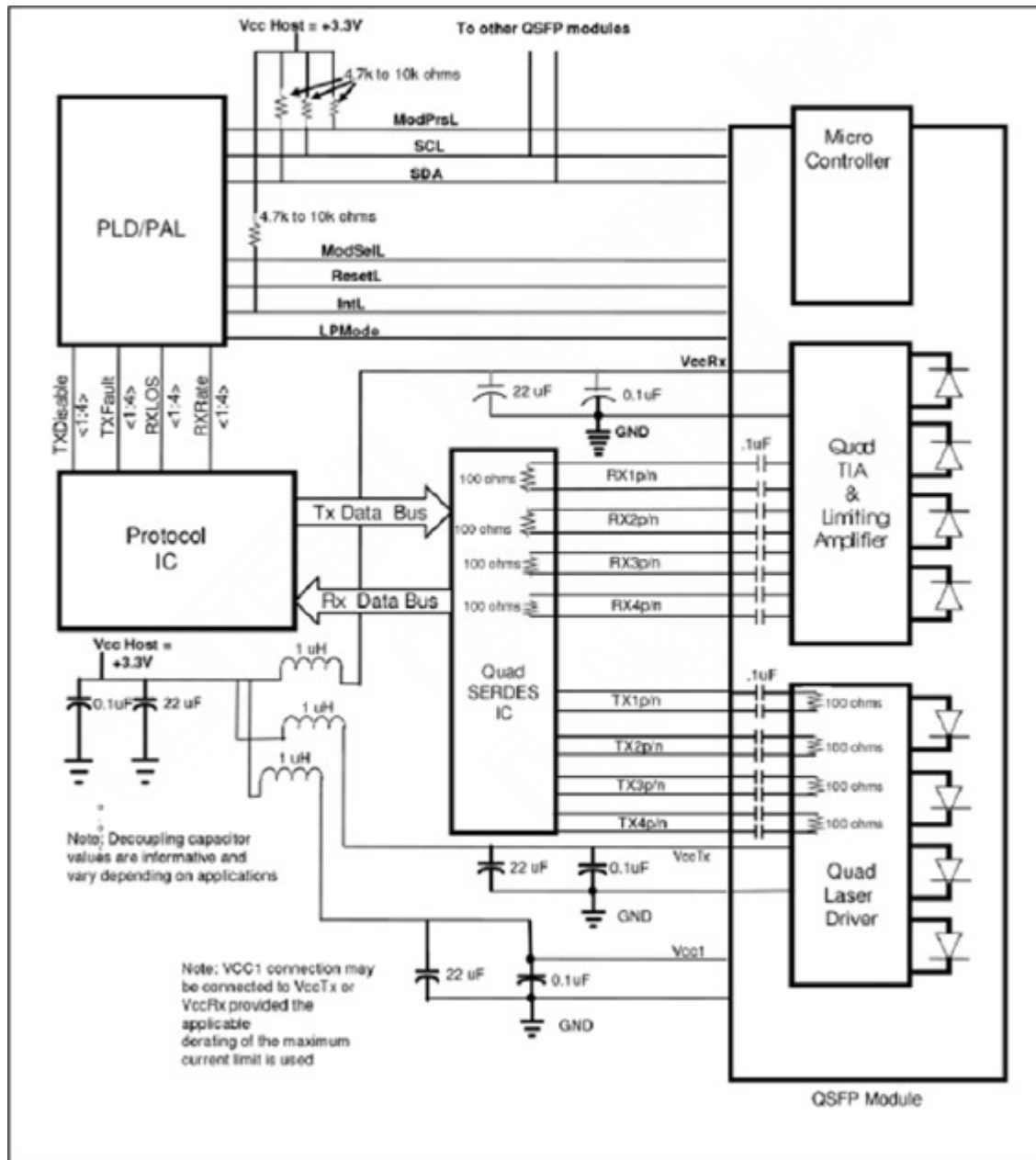

Memory Map

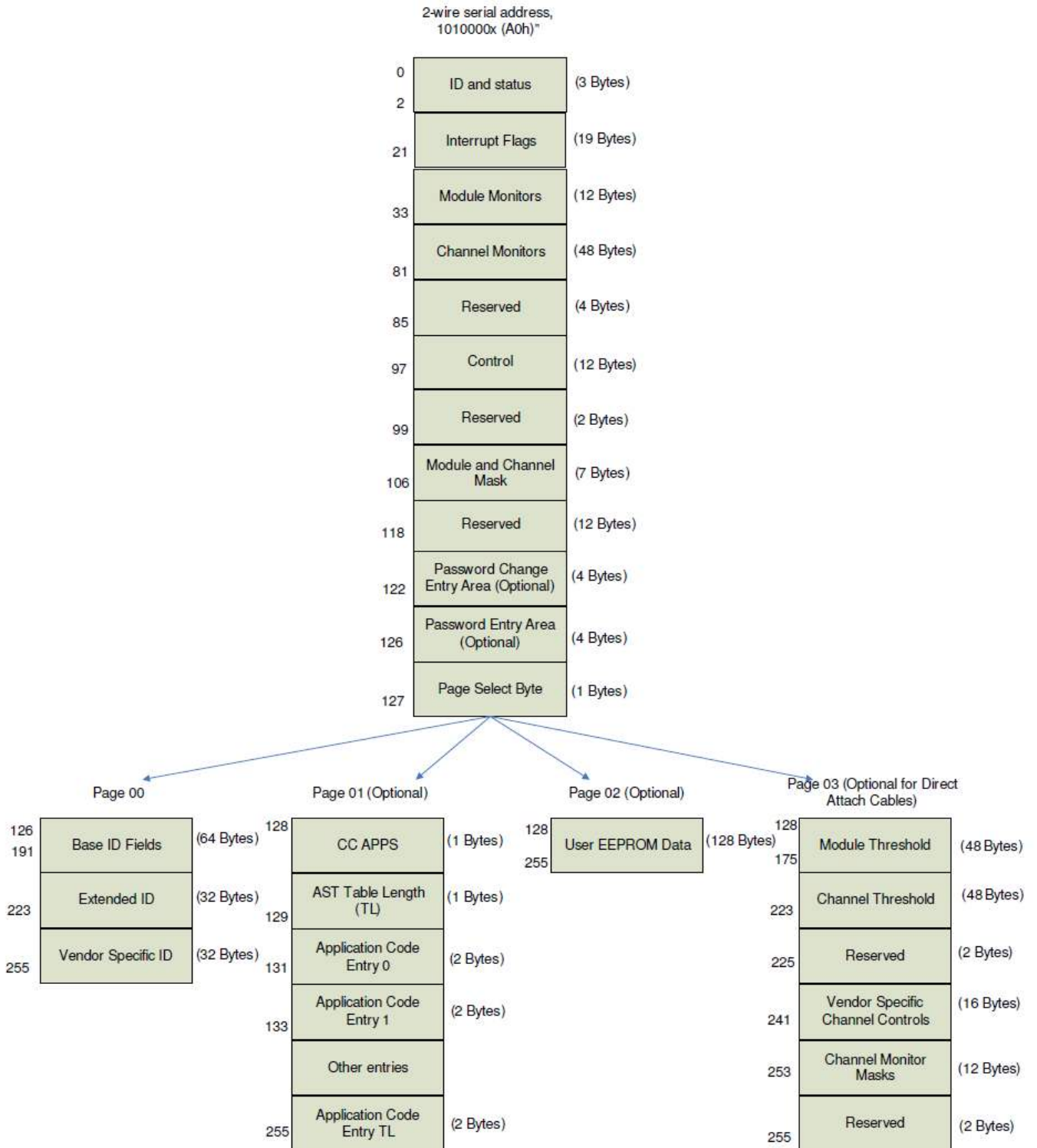

Contention 2-Wire Address A0H

Address	Description	Default/ Typical value
0	Identifier	0D
1	Reserved	00
2	Status	02
3	Rx LOS	00
4	Tx Fault	00
6	Temp High/Low alarm/warning	00
7	Vcc high/low alarm/ warning	00
22-25	Reserved	00
26-27	Supply voltage	
28-41	Reserved	00
42-49	Tx bias	
50-85	Reserved	00
86	Tx disable	00
87-106	Reserved	00
100-106	Module and Channel Masks	
107-118	Reserved	00
119-122	Password Change Entry Area (optional)	
123-126	Password Entry Area (optional)	
127	Page Select Byte	00

Address	Description	Default/ Typical value
128	Identifier	0D
129	Ext. Identifier	00
130	Connector	23
131-138	Module	04, 00, 00, 01, 40, 40, 04, 00
139	Encoding	05
140	BR, nominal	64
141	Extended rate select Compliance	00
142	Length(SMF)	00
143	Length(OM3 50 um)	00
144	Length(OM2 50 um)	Optional
145	Length(OM1 62.5 um)	00
146	Length(Copper)	00
147	Device tech	00
148-163	Vendor name	46,4F,52,4D,45,52,49,43,41,4F,45,20,20,20,20,20
164	Extended Module	04
165-167	Vendor OUI	00
168-183	Vendor PN	54,51,53,2D,51,31,4C,48,38,2D,58,43,41,78,78,20
184-185	Vendor rev	20,20
186-187	Wave length or Copper cable Attenuation	42, 68
188-189	Wavelength tolerance	07, D0
190	Max case temp.	46
191	CC_BASE	
192-195	Options	00,00,00,12
196-211	Vendor SN	
212-219	Date Code	
220	Diagnostic Monitoring Type	08
221-222	Enhanced Options	00
222	Reserved	00
223	CC_EXT	
224-255	Vendor Specific	

Address	Description	Default/ Typical value
128-129	Temp high alarm(80)	50,00
130-131	Temp low alarm(-5)	FB,00
132-133	Temp high warning(75)	4B,00
134-135	Temp low warning(0)	00,00
144-145	Vcc high alarm(3.6V)	8C,A0
146-147	Vcc low alarm(3.0V)	75,30
148-149	Vcc high warning(3.5V)	88,B8
150-151	Vcc low warning (3.1V)	79,18
176-177	Rx power high alarm(4dBm)	61,A8
178-179	Rx power low alarm(0.23dBm)	08,FC
180-181	Rx power high warning(3.4dBm)	55,28
182-183	Rx power low warning(0.288dBm)	0B,40
184-185	Tx bias high alarm(25mA)	30,D4
186-187	Tx bias low alarm(2mA)	03,E8
188-189	Tx bias high warning(23mA)	2C,EC
190-191	Tx bias low warning(4mA)	07,D0

Module Outline

Unit: mm

