

SSI Technologies – Application Note PS-AN4

MediaGauge™ (Model MG-9V) Digital Pressure Gauge

Product Overview

Product Description

The MediaGauge™ Model MG-9V digital pressure gauge is a stand alone 9V battery operated multi-functional digital pressure gauge. The MG-9V digital pressure gauge contains a media isolated piezoresistive pressure sensing element, signal conditioning circuitry for temperature and calibration compensation, a 304L stainless steel input pressure port and a LCD back lit display. The MG-9V digital pressure gauge has an **accuracy of ± 0.25 % full scale**. A battery power saver mode is incorporated into the MG-9V to automatically shut the LCD display off after 5 minutes prolonging the battery's life.

The MediaGauge™ MG-9V digital pressure gauge comes **standard** with a variety of keypad operated functions – multiple pressure unit display reading (PSI, BAR or MPA); memory storage of maximum peak pressure reading; and zero adjustment. A Ft of Head pressure measurement display is available as an option for the MG-9V model.

The MediaGauge™ MG-9V digital pressure gauge is made of all laser-welded 304L & 316L stainless steel for optimal media isolation and usage in a wide variety of media. These compact 3 inch, robust gauges measure pressures from **5 PSI to 5000 PSI** and are well suited for a variety of industrial and commercial applications such as refrigeration, compressors, pumps, hydraulics, pneumatics and waste water.

The MediaGauge™ MG-9V digital pressure gauge has better accuracy, longer life and standard multiple functions which make it a better choice than mechanical pressure gauges.



MediaGauge™ Model MG-9V and Model MG-9V-F

Product Features

- **Superb Accuracy:** ± 0.25% Full Scale
- **Pressure Ranges:** 5, 15, 50, 75, 100, 200, 300, 500, 750, 1000, 1500, 2000, 3000, 5000 PSI
- **Keypad operated functions:** Auto zero and peak hold
- **Operating Temperature:** -10°C to 60°C
- **Storage Temperature:** -20°C to 85°C
- **Typical Applications:** General Purpose, Test, Process Control, MRO, Water, Compressors, Refrigeration; Fuel Cells; Pumps; Hydraulics; Spraying Systems; Pneumatics; Flow; Robotics; Agriculture; Hydrogen Storage
- **NIST traceable certificates available**
- **NEMA 4X Rating**

SSI Technologies – Application Note PS-AN4

MediaGauge™ (Model MG-9V) Digital Pressure Gauge

Product Overview

- **Chemical Compatibilities:** Any gas or liquid compatible with 304L and 316L stainless steel. For example, Motor Oil, Diesel, Hydraulic fluid, Brake Fluid, Water, Waste Water, Hydrogen, Nitrogen, and Air.
- **LCD Display Battery Saver Mode:** MG-9V automatically powers down after 5 minutes.
- **Multiple Pressure Units:** PSI, BAR, MPA (kg/cm²) (Optional Ft. of Head available)
- **Compact, Robust Package:** 3 inches with black ABS Thermoplastic case

Measurement Technology

In general, pressure measurement technology translates a force from an induced pressure into an electrical quantity. In digital pressure gauges, the electrical quantity is then translated into pressure units and digitally displayed.

The SSI's MediaGauge™ MG-9V digital pressure gauge includes an 304L stainless steel input pressure port, a piezoresistive pressure sensing element, signal conditioning circuitry for temperature and calibration compensation, and a LCD that displays the pressure measured in either PSI, BAR or MPA (kg/cm²) units.

The piezoresistive sensing element consists of an oil-filled micro-machined 316L stainless steel convoluted diaphragm and a silicon crystal sensor. The silicon crystal sensor is mounted on a 304L stainless steel housing and laser welded to the diaphragm. Optimal media isolation is achieved when the media's pressure acts directly on the

316L stainless steel diaphragm and is then transferred through the oil to the silicon sensor.

Strain gauges (resistive elements) in the silicon sensor are used in a Wheatstone Bridge circuit. When the media's pressure is applied, the resistivity of the strain gauges changes proportional to the pressure applied. One leg of the bridge measures the input pressures port. The other leg of the bridge is connected to the reference port (vacuum pressure 0 PSI) the input pressure port is compared to.

Since piezoresistive pressure sensors are generally sensitive to changes in temperature, the MediaGauge™ MG-9V digital pressure gauge uses signal conditioning to compensate for temperature and calibration. The output signal is then converted into one of 3 user selectable forms (select units with the ON/UNIT/OFF button):

- 1) PSI
- 2) BAR
- 3) MPA (kg/cm²)

The MediaGauge™ MG-9V digital pressure gauge will display the pressure reading after the ON/UNIT/OFF button is depressed. The pressure measurement reading is updated 3 times per second.



SSI Technologies – Application Note PS-AN4

MediaGauge™ (Model MG-9V) Digital Pressure Gauge

Product Overview

MediaGauge™ MG-9V Panel Operation

The MediaGauge™ MG-9V panel has a LCD display and three multi-functional buttons – *ON/UNIT/OFF*; *Backlight/P-H* (Peak-Held) and *RESET/CLEAR*.



The *ON/UNIT/OFF* button is used to display the pressure reading; switch between pressure units (PSI; BAR; and MPA) and to power down the unit.

To power on the unit: Press the ON/UNIT/OFF button. The MediaGauge™ MG-9V has a battery saver mode and will automatically shut off the display after 5 minutes.

To display the pressure reading in a different pressure unit: Continue to depress the ON/UNIT/OFF button until the arrow in the LCD points to the pressure units desired.

To manually power down the unit: Press the ON/UNIT/OFF button and hold down for 3 seconds until OFF is displayed and then release the button.

The *Backlight/P-H (Peak-Held) button* is used to turn the LCD backlight on/off and to display the maximum peak pressure the unit has measured.

To turn the LCD backlight on: Press the Backlight/P-H button once. *To turn the LCD backlight off:* Press the button again.

To see the maximum peak pressure the unit has measured: Press and hold down the Backlight/P-H button for 3 seconds. The maximum pressure reading will be blinking. If the maximum pressure read was over the unit's maximum pressure range, o.L will be blinking on the display.

To return to the current pressure reading: Press the Backlight/P-H button and hold down for 3 seconds.

The *RESET/CLEAR* button is used to reset the gauge to whatever pressure is currently applied to the port and to clear the stored maximum peak pressure reading.

To reference your MediaGauge™ digital pressure gauge to the input port: Press and hold the RESET/CLEAR button for 3 seconds. The MediaGauge™ MG-9V will now be reference to your input port. For example, if you have 20 psi on the display and then you press and hold the RESET/CLEAR button for 3 seconds the display will show 0.0 psi. A measurement of 30 psi would then read as 10 psi on the display.

To reset the MediaGauge™ digital pressure gauge: Make sure the input port is either disconnected or connected to a 0 psi input. Press and hold down the RESET/CLEAR button for 3 seconds.

SSI Technologies – Application Note PS-AN4

MediaGauge™ (Model MG-9V) Digital Pressure Gauge

Product Overview

To clear the maximum peak pressure reading: Press and hold down the Backlight/P-H button for 3 seconds until the maximum pressure reading appears on the LCD (it will be blinking). Release the Backlight/P-H button. Press and hold down RESET/CLEAR button for 3 seconds.

Electrical Specifications

Supply Voltage	9V Battery
Response Time	< 1 ms
Accuracy (75-3000 PSI)	± 0.25 FS
Thermal Error typ. (75-3000 PSI)	± 0.25 FS
Total Error (75-3000 PSI)	± 0.25 FS
Accuracy (15-50 PSI)	± 0.50 FS
Thermal Error Typ. (15-50 PSI)	± 0.50 FS
Total Error (15-50 PSI)	± 0.50 FS
Accuracy (5 PSI)	± 1.00 FS
Thermal Error Typ. (5PSI)	± 1.00 FS
Total Error (5PSI)	± 1.00 FS

Electrical Specifications (Cont.)

Stability (Typical)	< 0.25% Full Scale/Year
LCD Resolution (5 PSI)	X.000
LCD Resolution (15 to 75 PSI)	XX.00
LCD Resolution (100 to 750 PSI)	XXX.0
Proof Pressure	3 X Full Scale
Burst Pressure	10 X Full Scale or 15,000 PSI whichever is less
Operating Temperature Range	-10° to 60°C (14° to 140°F)
Storage Temperature Range	-20° to 85°C (-4° to 185°F)



SSI Technologies – Application Note PS-AN4

MediaGauge™ (Model MG-9V) Digital Pressure Gauge

Product Overview

Tested Conditions

Humidity	250 Hours (40°C and 90% to 95% R.H.)
Pressure/Temperature Cycles	> 1.8 million Cycles (0 to FS @ 8Hz and -20° to 85°C)
Thermal Shock	250 Cycles (85 to -20°C. 0.5 hr soaks at temperature)
Vibration	144 Hours (100 to 2000 Hz, 20g sinusoidal in 3 axes)

Installation/Mounting

- 1) Mount the MediaGauge™ MG-9V digital pressure gauge on a suitable (1/4" or 1/8" NPT) female fitting. Use Teflon tape or pipe dope to seal the threads.
- 2) Do not over tighten. Torque to 150 in lbs +/- 1 in lb.



SSI Technologies – Application Note PS-AN4

MediaGauge™ (Model MG-9V) Digital Pressure Gauge

Product Overview

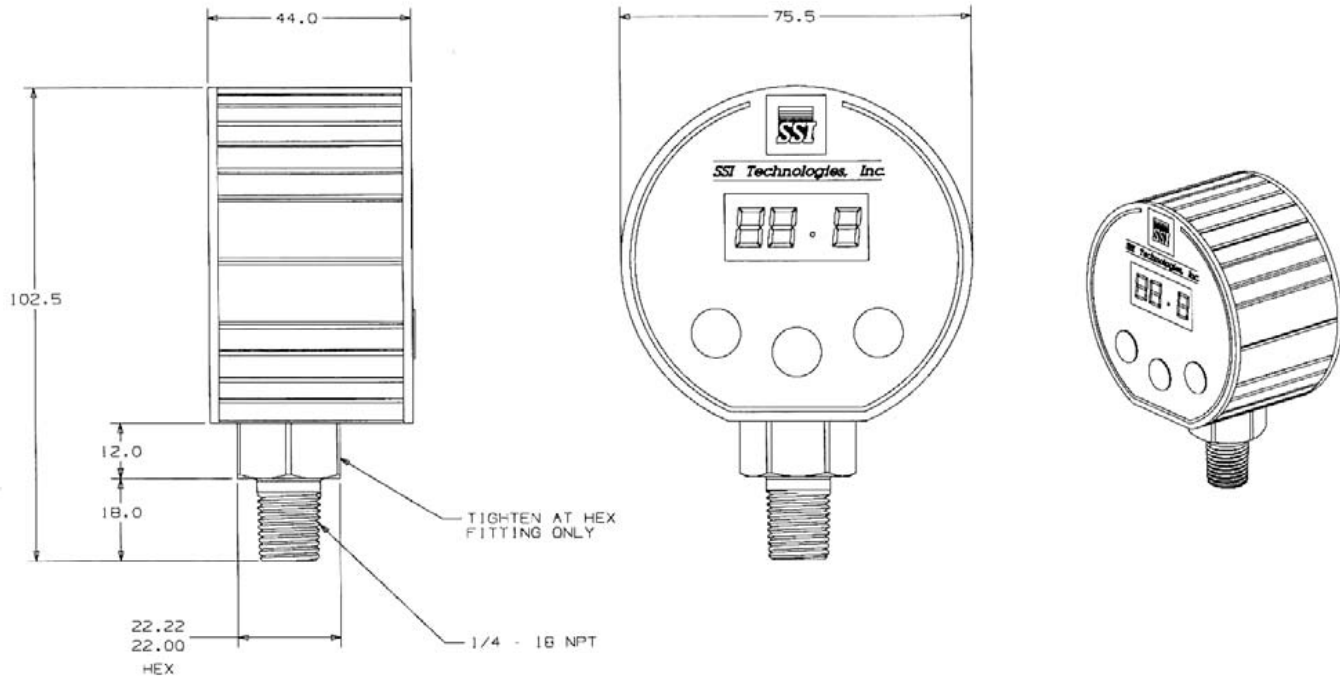

MediaGauge™ with 22mm Hex and 1/4" - 18 NPT Process Connection



SSI Technologies – Application Note PS-AN4

MediaGauge™ (Model MG-9V) Digital Pressure Gauge

Product Overview

Digital Pressure Gauge Ordering System

The following explains SSI's MediaGauge™ Digital Pressure Gauge order number sequence.

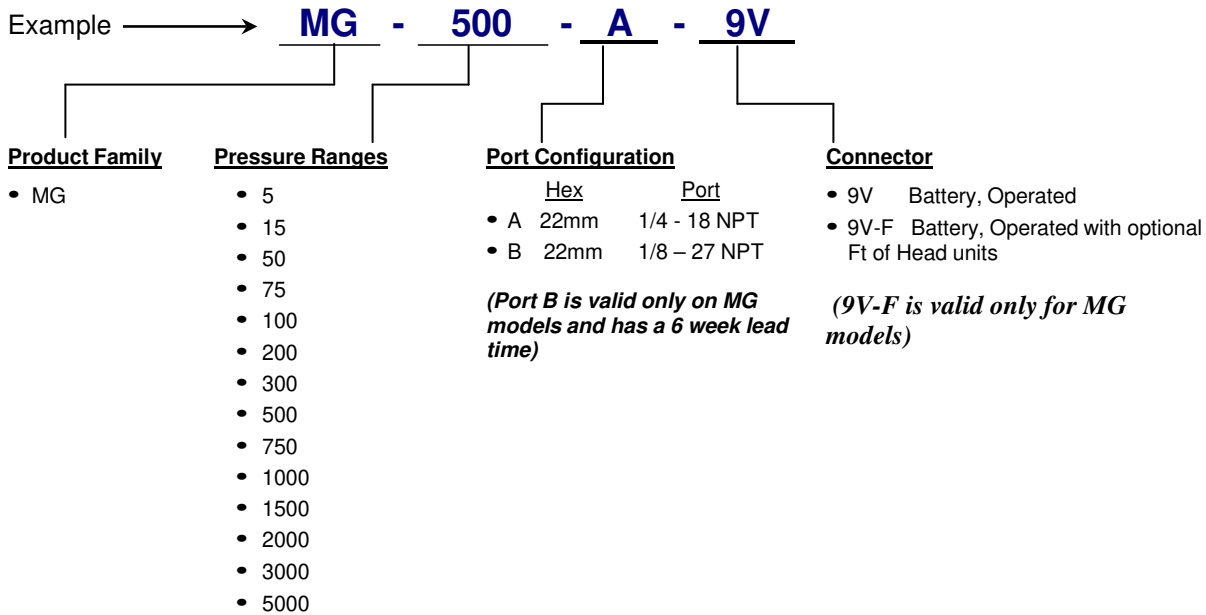

Ft of Head Options

MG 100 – A – 9V – F
 200 – A – 9V – F
 300 – A – 9V – F

Rubber Boot Options:

Order P/N 14405.1 for Model MG

