

REVISIONS					
P	LTR	DESCRIPTION	DATE	DWN	APVD
	K2	REVISED PER ECO-11-004587	11MAR11	RK	HMR
	K3	REVISED PER ECO-17-010308	25OCT2017	RS	DR

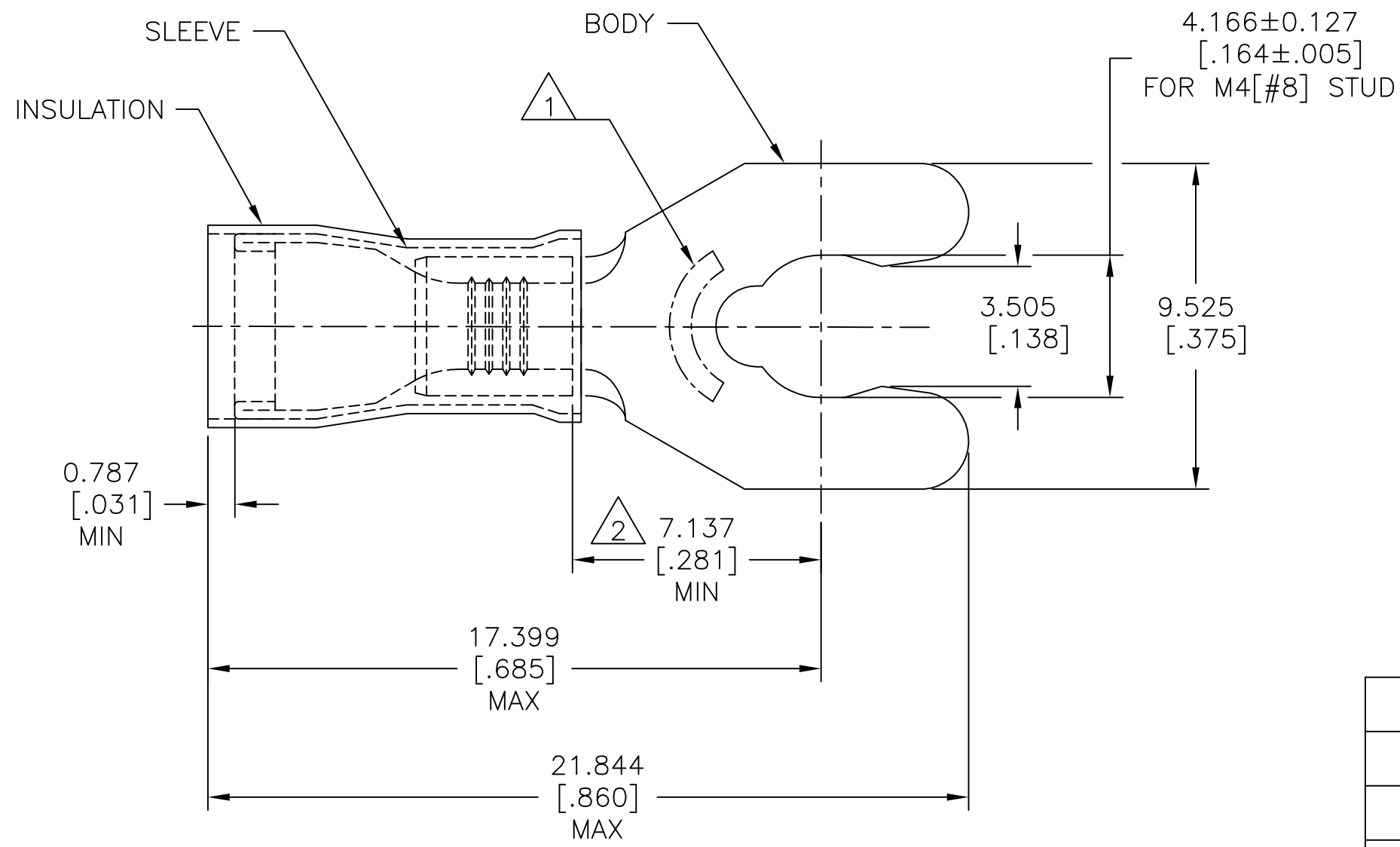

- 1 STAMP 8S AMP 16-14\*, APPROX AS SHOWN.
- 2 APPLIES FROM EDGE OF METAL WIRE BARREL TO CENTER OF STUD HOLE.
- 3 BODY MATERIAL THK IS 0.787±0.051 [.031±.002]
- 4 BODY - PHOS BRONZE PER ASTM B-103  
SLEEVE - COPPER PER ASTM B-152  
INSULATION - NYLON.
- 5 BODY - TIN PLATE PER ASTM B545  
SLEEVE - TIN PLATE PER ASTM B545  
INSULATION - COLOR - BLUE.

<b>AMP</b> WIRE RANGE	<b>UL</b> Listed FILE E13288	<b>SR</b> LR7189 Certified
16-14 AWG SOLID OR STRANDED	16-14 AWG SOLID OR STRANDED	16-14 AWG SOLID OR STRANDED

WIRE INSULATION OD	QTY	PACKAGE TYPE	PART NO
.115-.170	100	LOOSE PIECE, BOX	8-52936-1
.115-.182	4000	-2 ON TAPE	52936-3
.115-.182	1000	LOOSE PIECE	52936-2
.115-.170	4000	-1 ON TAPE	52936-1
.115-.170	1000	LOOSE PIECE	52936

<b>CUSTOMER SERVICE SYSTEMS</b>	
FOR ADDITIONAL PRODUCT INFORMATION OR COPIES OF DRAWINGS AND TECHNICAL DOCUMENTS	PRODUCT INFORMATION CENTER 1-800-522-6752
FOR APPLICATION TOOLING INFORMATION	TOOLING ASSISTANCE CENTER 1-800-722-1111
FOR ORDER ENTRY	1-800-526-5142

MAX RECOMMENDED OPERATING TEMPERATURE: 105°C [221°F]
VOLTAGE RATING: 300 V MAX
CIRCULAR MIL AREA: 1.04-2.62mm² [2,050-5,180] SOLID OR STRANDED

THIS DRAWING IS A CONTROLLED DOCUMENT.	
DIMENSIONS: mm [INCHES]	TOLERANCES UNLESS OTHERWISE SPECIFIED:
	0 PLC ± -
	1 PLC ± -
	2 PLC ± -
	3 PLC ± 0.127 [.005]
	4 PLC ± -
	ANGLES ± 5°
MATERIAL	FINISH
4	5

DWN jr_ruth 19MAR10	<b>STE</b> TE Connectivity		
CHK T MICHELUTTI 19MAR10			
APVD T MICHELUTTI 19MAR10	NAME		
PRODUCT SPEC UL486 A-B	TERMINAL, SHORT SPRING SPADE, PIDG, WIRE SIZE: 16-14 AWG		
APPLICATION SPEC 114-2157	SIZE	CAGE CODE	DRAWING NO
WEIGHT -	A3	00779	C-52936
CUSTOMER DRAWING		SCALE 6:1	SHEET 1 OF 1
		RESTRICTED TO -	REV K3