

ITEM	Q'TY	PART NUMBER	PART DESCRIPTION
1	1	CPCI-TGX-B	Transition Card Guide, Bottom, SEE SHEET TABLE 1
2	1	CPCI-ESD1	CPCI ESD Clips, PCB Grounding, SEE SHEET 2

REV.	DESCRIPTION	DATE	APPROVED
A	Engineering Release.	08/21/14	J. C.

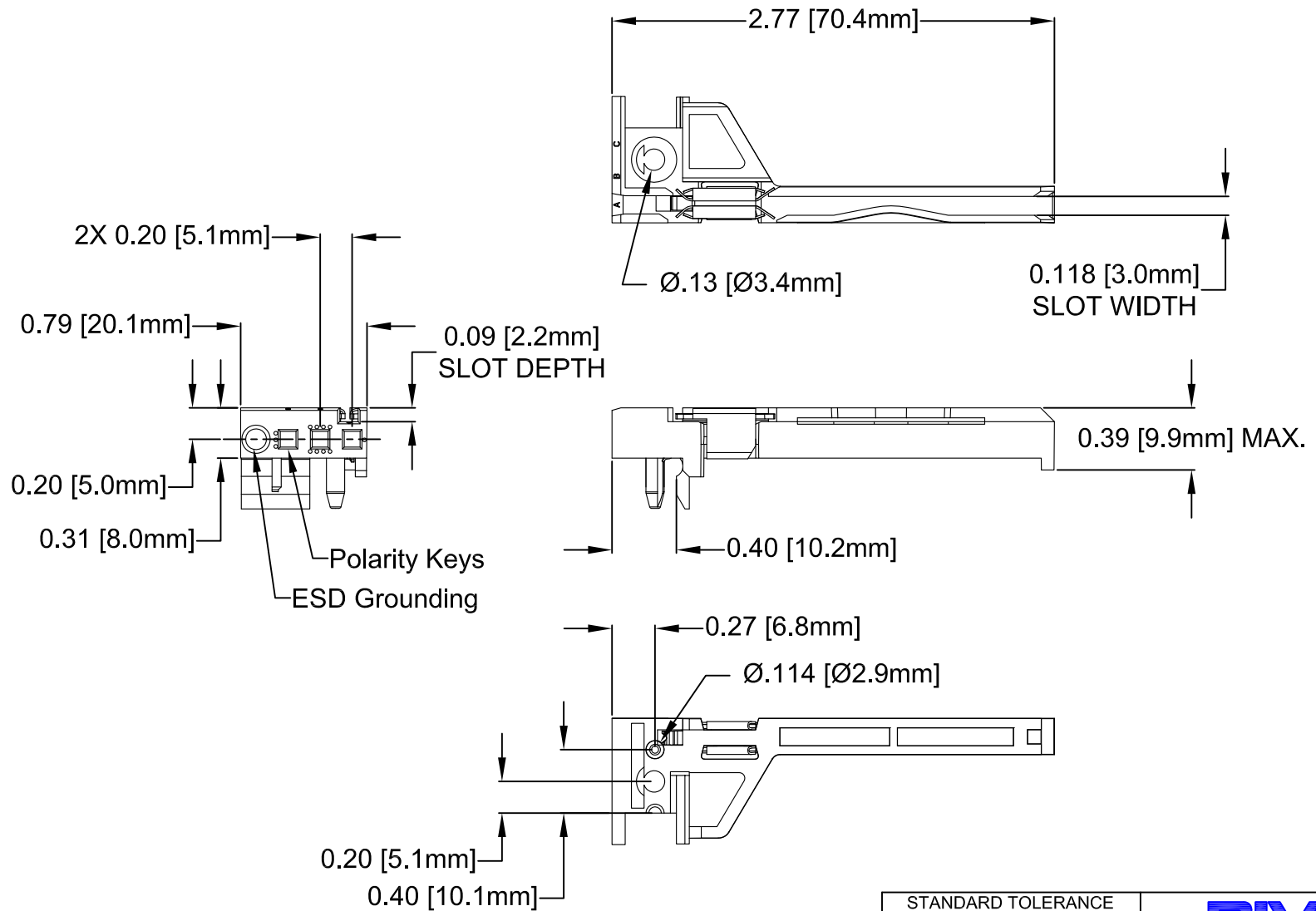

2. MATERIAL: POLYCARBONATE, 20% GLASS FILLED

1. GENERAL SPECIFICATIONS: BIVAR MOLDED COMPONENT SPECIFICATION BV00-E101.

STANDARD TOLERANCE (UNLESS OTHERWISE SPECIFIED)		BIVAR [®]	4 THOMAS, IRVINE, CA. 92618 TEL: (949) 951-8808 FAX: (949) 951-3974
DECIMALS	ANGULAR		
.X ±.1	X° ± 1°		TITLE: TRANSITION CARD GUIDE WITH ESD CLIP, BOTTOM PART NO: CPCI-TGX-B-ESD1 REVISION: A
.XX ±.01			
.XXX ±.005			
DESIGNED: Alex Wright	DATE: 08/21/14	CAGE CODE : 32559 SHEET # 1 OF 2	
CHECKED: Brian Oliver	DATE: 08/21/14	CAD GENERATED DOCUMENT, DO NOT MEASURE DRAWING.	

REV.	DESCRIPTION	DATE	APPROVED
	SEE SHEET #1		

CPCI-ESD1
PCB EDGE GROUNDING

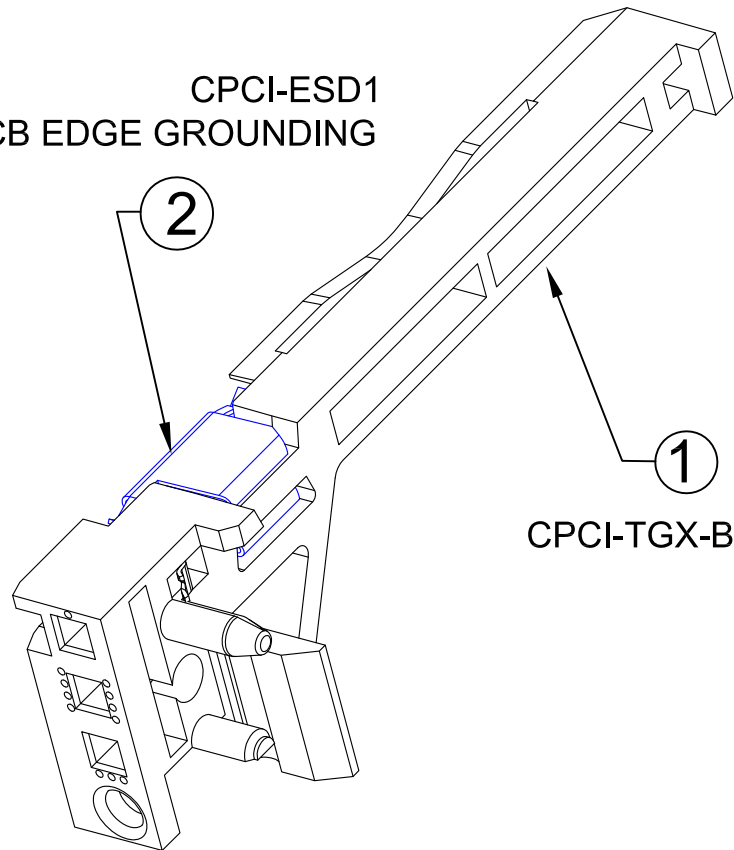

CPCI-TGX-B

TABLE 1
ASSEMBLY CONFIGURATIONS

ASSEMBLY PART NUMBERS	COLOR
CPCI-TG-B-ESD1	GREY
CPCI-TGY-B-ESD1	YELLOW

NOTE: ESD CLIP COMES PRE-ASSEMBLED

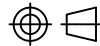
STANDARD TOLERANCE (UNLESS OTHERWISE SPECIFIED)		 4 THOMAS, IRVINE, CA. 92618 TEL: (949) 951-8808 FAX: (949) 951-3974	
DECIMALS	ANGULAR		
.X ± .1	X° ± 1°	 TITLE: TRANSITION CARD GUIDE WITH ESD CLIPS, BOTTOM	REVISION: A
.XX ± .01			
.XXX ± .005			
DESIGNED: Alex Wright	DATE: 08/21/14	PART NO: CPCI-TGX-B-ESD1	
CHECKED: Brian Oliver	DATE: 08/21/14	CAGE CODE : 32559	SHEET # 2 OF 2
CAD GENERATED DOCUMENT, DO NOT MEASURE DRAWING.			