

PART NO.	ENGINEERING NO.	FINISHED LENGTH
1300061309	105000C01F030	3FT [0.9M]
1300061314	105000C01F120	12FT [3.7M]
1300061320	105000C01F250	25FT [7.6M]

## PART NUMBER LEGEND

105000C01F030

CABLE LENGTH  
 F010 = 1 FEET  
 F010 = 10 FEET  
 F100 = 100 FEET

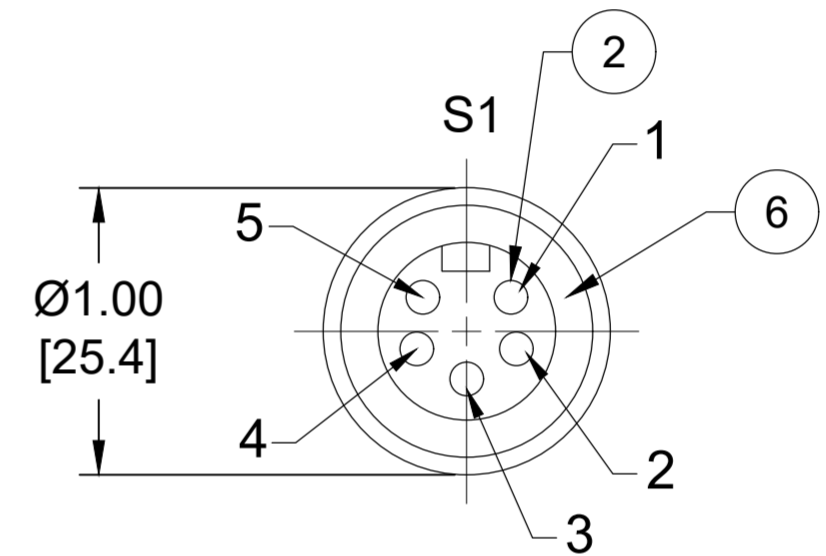
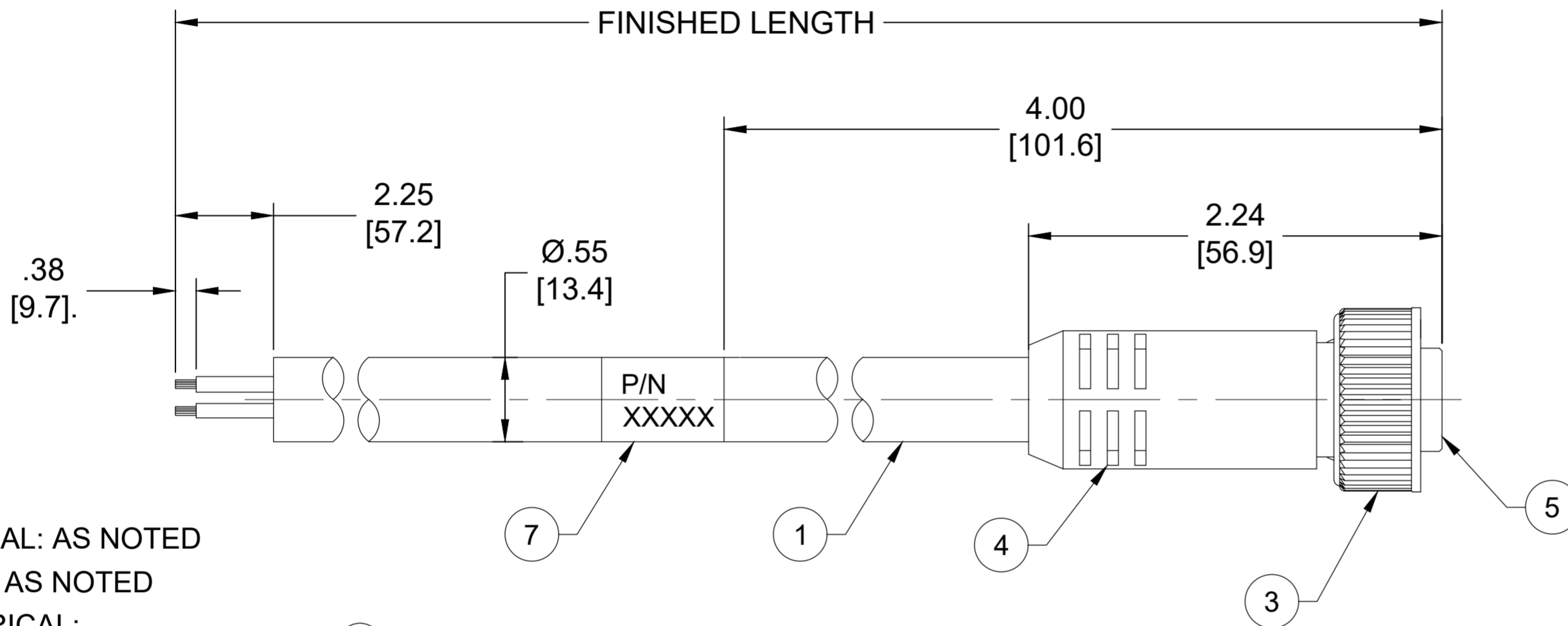
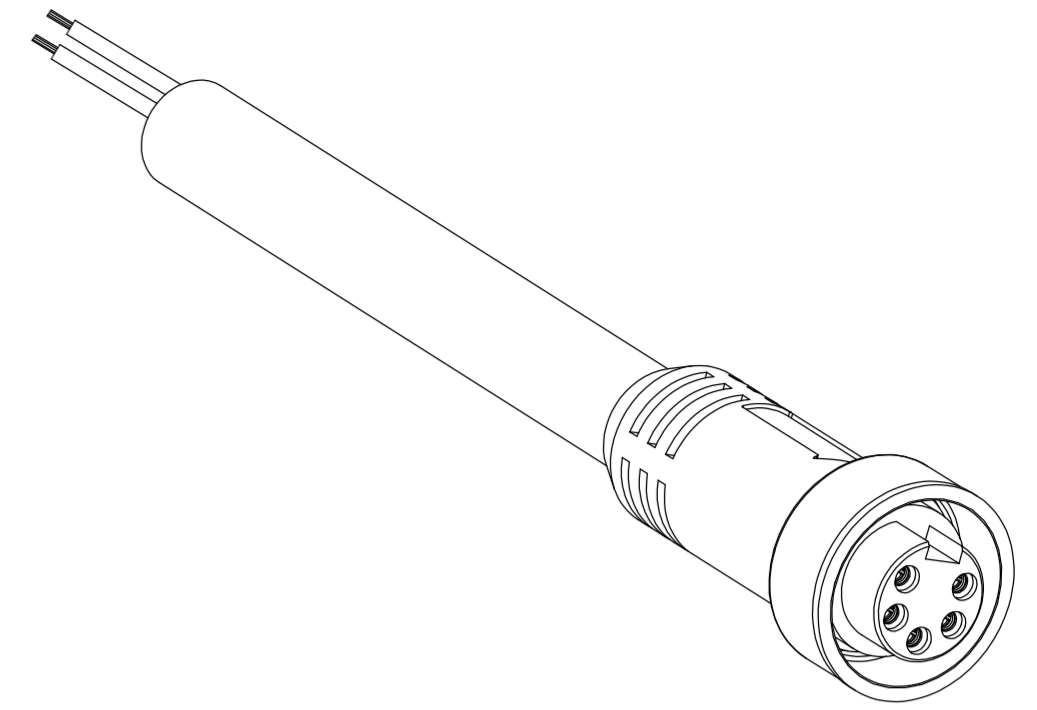

FEMALE FACE VIEW

NOTES:

- MATERIAL: AS NOTED
- FINISH: AS NOTED
- ELECTRICAL:  
 VOLTAGE : 400V PER IEC 60664  
 600V PER UL 2238  
 CURRENT: 8A
- TEMP RATING: -20° TO +105°C
- PROTECTION: IP67 (WHEN MATED)
- COUPLING THREAD: 7/8"-16UN
- CSA CERTIFIED FILE: LR6837
- ALL DIMENSIONS ARE FOR REFERENCE UNLESS TOLERANCED OR NOTED OTHERWISE

	S1
RED WITH WHITE	1
RED	2
GREEN-GND	3
RED WITH ORANGE	4
RED WITH BLACK	5

WIRING DIAGRAM

CABLE LENGTH TOLERANCES
<.3M [1FT]: +19mm-0 [ +.75in-0]
.3 - .9M [1 - 3FT]: +44.5mm-0 [+1.75in-0]
.9 - 1.8M [3 - 6FT]: +55.6mm-0 [+2.19in-0]
1.8 - 3.7M [6 - 12FT]: +88.9mm-0 [+3.50in-0]
3.7 - 7.3M [12 - 24FT]: +165.1mm-0 [+6.50in-0]
7.3-14.6M [24 - 48FT]: +317.5mm-0 [+12.50in-0]
14.6 - 30.5M [48-100FT]: +622.3mm-0 [+24.50in-0]
OVER 30M [100FT] +2% OF FINISHED LENGTH

ITEM	COMPONENT	MATERIAL	FINISH
7	WRAP LABEL	VINYL	BLACK/YELLOW
6	FRICITION RING	NYLON	WHITE
5	INSERT	TPE	YELLOW
4	OVERMOLD	TPE	YELLOW
3	COUPLING NUT	ZINC DIE CAST	BLACK-E-COAT
2	CONTACT SOCKET	COPPER ALLOY	GOLD OVER NICKEL
1	CABLE, 16 AWG	RUBBER	YELLOW

FUNCTIONAL SYMBOLS FA=0 FC=0 FP=0	DIMENSION UNITS <b>INCH/MM</b>	SCALE <b>NTS</b>	CURRENT REV DESC: ITEM# 4 & 5 WERE PVC.ITEM #7 WAS MYLAR. ADDED ITEM #6, IEC VOLTAGE, PN LEGEND & TOL CHART. MODIFIED PN CHART & TEMP RATING.	
	GENERAL TOLERANCES (UNLESS SPECIFIED)		EC NO: 698916	DRWN: ABENJAMINLW 2021/05/20
DIVISIONAL SYMBOLS	4 PLACES ±----	±----	CHK'D: RSTONE 2022/03/09	APPR: BWOODMAN 2022/03/11
	3 PLACES ±----	±----	INITIAL REVISION:	
	2 PLACES ±----	±----	DRWN: BWOODMAN 2009/12/28	APPR: JFMURPHY 2010/01/05
	1 PLACE ±----	±----	THIRD ANGLE PROJECTION	
	0 PLACES ±----	±----	DRAWING <b>C-SIZE</b>	SERIES <b>130006</b>
ANGULAR TOL ± ---- °		MATERIAL NUMBER <b>SEE CHART</b>		
DRAFT WHERE APPLICABLE MUST REMAIN WITHIN DIMENSIONS		CUSTOMER <b>GENERAL MARKET</b>		

**molex**

MINI-CHANGE CORDSET, A-SIZE  
 5-POLE, FEMALE, STRAIGHT, SINGLE KEY,  
 #16 AWG

PRODUCT CUSTOMER DRAWING

DOCUMENT NUMBER: **SD-130006-022**    DOC TYPE/DOC PART/REVISION: **PSD 001 B**

SHEET NUMBER: **1 OF 1**