

THIS COPY IS PROVIDED ON A RESTRICTED BASIS AND IS NOT TO BE USED IN ANY WAY DETRIMENTAL TO THE INTERESTS OF PANDUIT CORP.

NOTES:

1. VISIT OUR ON-LINE CATALOG AT WWW.PANDUIT.COM FOR A LIST OF CURRENT PARTS APPLICABLE USE WITH THIS PRODUCT.
2. PRODUCT IS REMOVED THE USB TYPE "C" FEMALE PORT USING THE SMARTKEEPER MASTER KEY (PANDUIT P.N.: SKMKEY).
3. SEE INSTALLATION INSTRUCTION FOR PROPER USE OF PRODUCT.
4. PARTS INCLUDES (DESCRIPTION: MATERIAL/COLOR):
 - 4A. EXTERNAL BODY SHELLS: POLYCARBONATE (PC), FLAME RATING: UL94 V-0/RED.
 - 4B. SMARTKEEPER INTERNAL BODY W/ UNIQUE FEMALE KEYED PATTERN, FLAME RATING: UL94 V-0/RED.
 - 4C. MAIN BODY CLIP: BRASS STEEL/NICKEL.
 - 4D. SMARTKEEPER SIDE SHIELD: BRASS STEEL/NICKEL.
 - 4E. USB TYPE "C" INTERNAL SUPPORT: POLYCARBONATE (PC), FLAME RATING: UL94 V-0/RED.
 - 4F. USB TYPE "C" SIDE EXTERNAL SHIELD: BRASS STEEL/NICKEL.
5. PRODUCT IS DESIGNED FOR INDOOR USE ONLY.
6. OPERATING TEMPERATURE AND HUMIDITY RANGE:
 - 6A. TEMPERATURE RANGE: -4°F (-20°C) TO +140°F (+60°C)
 - 6B. HUMIDITY RANGE: 10-70% NON-CONDENSING RELATIVE HUMIDITY.
7. STORAGE CONDITIONS:
 - 7A. TEMPERATURE RANGE: -4°F (-20°C) TO +176°F (+80°).
 - 7B. HUMIDITY RANGE: 10-80% NON-CONDENSING RELATIVE HUMIDITY.
8. WEIGHT: 0.07 LBS/ (10) PCS [33.5 grams/ (10) PCS].
9. DIMENSIONS IN [] ARE METRIC.
10. ALL MATERIALS AND COMPONENTS USED MEET THE MATERIALS RESTRICTIONS OF RoHs, (EUROPEAN DIRECTIVE 2011/65/EU ON THE RESTRICTION OF HAZARDOUS SUBSTANCES) AS PROPOSED BY THE RoHs TECHNICAL ADAPTATION COMMITTEE.

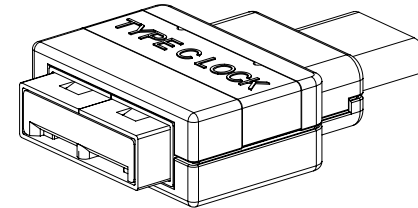
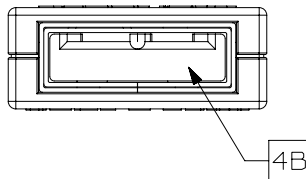
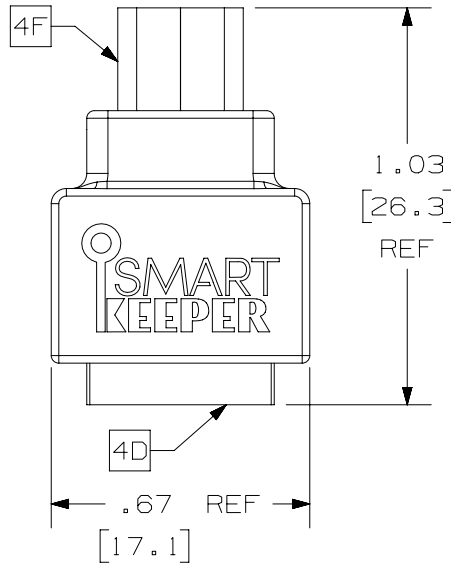
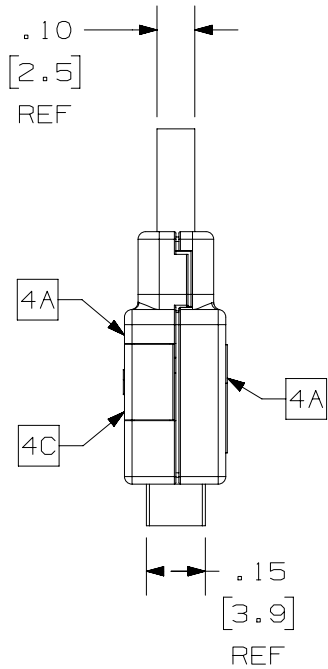
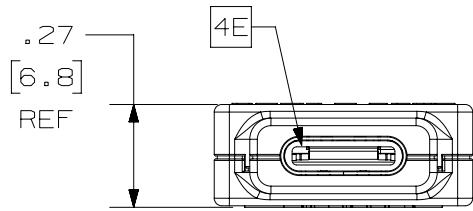

SCALE 2:1

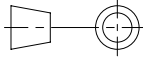
| | | | | |
|---|----------|--|-------|--------------|
| PART NUMBER | | SKUSBC | | |
| TITLE | | SMARTKEEPER USB TYPE "C" BLOCKOUT DEVICE | | |
| ITEM REVISION NAME | | CUSTOMER DRAWING | | |
| DATASET FILE NAME | | 00402NAC/00 | | |
| | | 00402NAC_DC/00A | | |
|  | | THIRD ANGLE PROJECTION | | |
| MATERIAL | | SEE NOTES | | |
| DRAWING NUMBER | | 00402NAC-DC | | |
| DRAWN BY | DATE | CHK | SCALE | SHEET 1 OF 1 |
| MDJR | 04-25-19 | DCS | 2:1 | A |

| | | | | | | |
|-----|----------|------|-----|-----|------------------|-------------|
| 00A | 04-25-19 | MDJR | DCS | MMR | DRAWING RELEASED | 00402NAB-DC |
| REV | DATE | BY | CHK | APR | DESCRIPTION | ECN |

A-SIZE CUSTOMER