

5 AMPLIVAR SERRATIONS

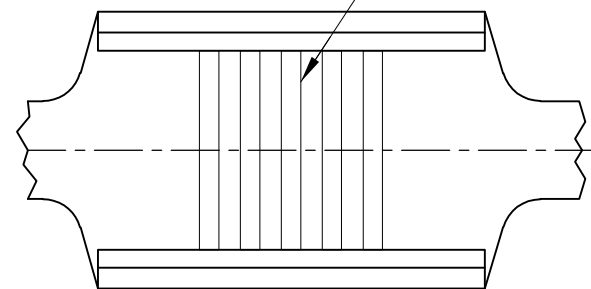

1 CONTINUOUS STRIP ON REELS.

2 WIRE SIZE IS 1500-5000 CMA  $\triangle 3$

$\triangle 3$  CRIMP WIDTH: .110 F TYPE (AMPLIVAR THRU)  
CRIMP HEIGHT ( $\pm 0.002$ ) = (TOTAL CMA + 10,700) / 193,400  
GENERAL APPLICATION GUIDELINES MUST BE FOLLOWED AS SPECIFIED IN CATALOG #82221  
FOR APPLICATOR INFORMATION CALL: 1-800-722-1111  
FOR PRODUCT INFORMATION CALL: 1-800-522-6752

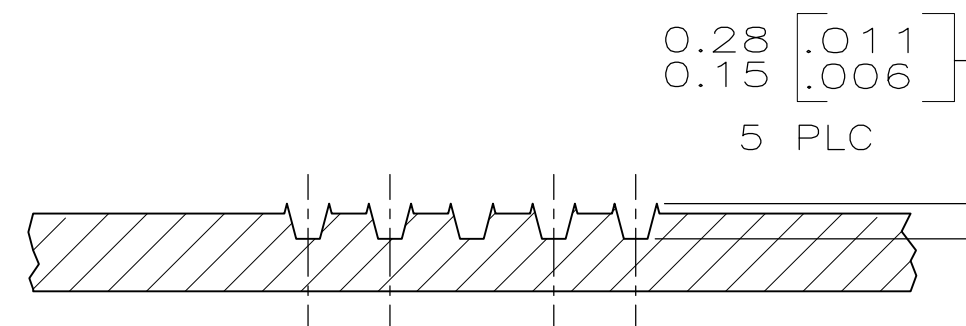
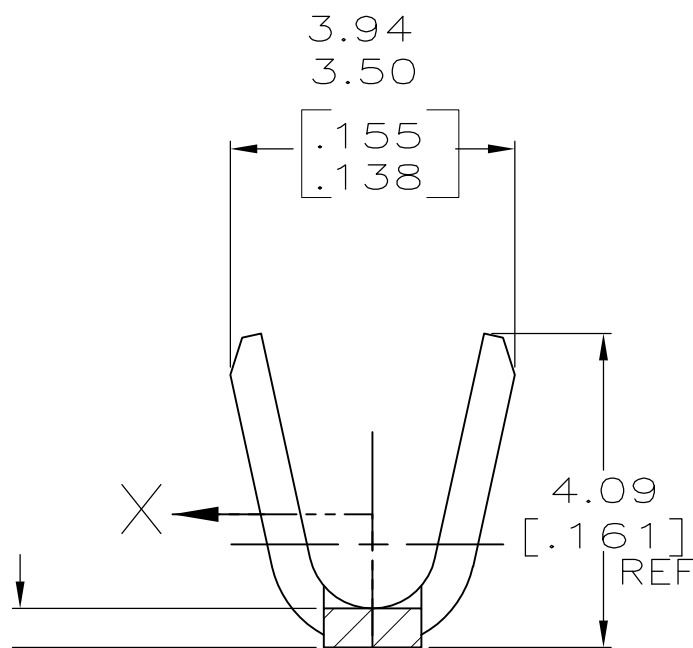
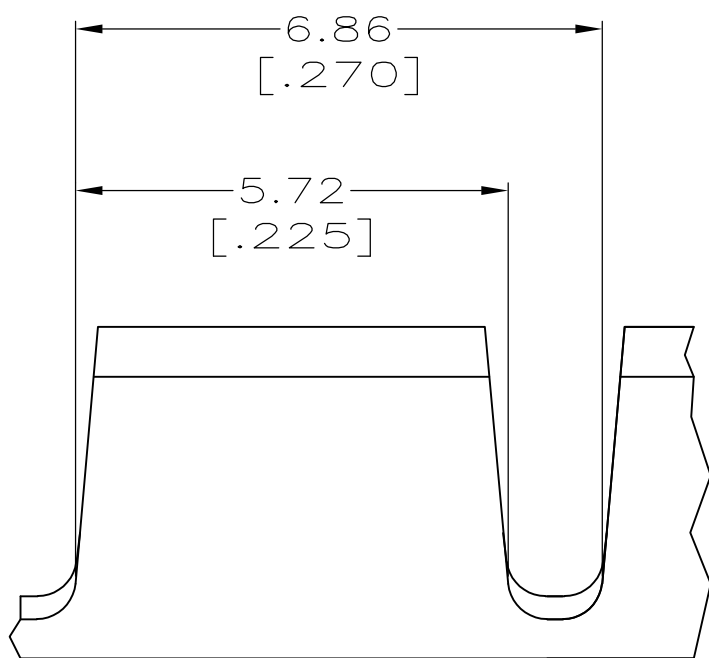

SECTION A-A  
SCALE 20:1

41899

PART NO.

THIS DRAWING IS A CONTROLLED DOCUMENT.

DWN JR RUTH 08SEP00

CHK MS FEHER 08SEP00

APVD G PORTA 08SEP00

PRODUCT SPEC

APPLICATION SPEC

114-2009

WEIGHT -

CUSTOMER DRAWING



AMP Incorporated  
Harrisburg, PA 17105-3608

SPLICE, AMPLIVAR

SIZE CAGE CODE DRAWING NO RESTRICTED TO

A3 00779 C- 41899 -

SCALE 10:1 SHEET 1 OF 1 REV E

DIMENSIONS:  
MM [INCHES]

TOLERANCES UNLESS OTHERWISE SPECIFIED:

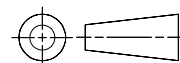

0 PLC ±-  
1 PLC ±-  
2 PLC ±0.38 [.015]  
3 PLC ±-  
4 PLC ±-  
ANGLES ±-

MATERIAL BRASS

FINISH TIN PLATE