

FEATURES

- Wide bandwidth: dc to 20 GHz
- Low phase shift vs. attenuation
- 30 dB attenuation range up to 12 GHz
- Hermetically sealed module
- Field replaceable SMA connectors
- Operating temperature: -55°C to $+85^{\circ}\text{C}$

APPLICATIONS

- Telecom infrastructure
- Military radio, radar, and ECM
- Space systems
- Test instrumentation

GENERAL DESCRIPTION

The **HMC-C053** is an absorptive voltage variable attenuator (VVA) operating from dc to 20 GHz. The **HMC-C053** features a simple single voltage attenuation control, 0 V to -3 V. The device is ideal in designs where an analog dc control signal must control radio frequency (RF) signal levels over a 30 dB amplitude range. Its broad frequency range makes it an attractive choice for many applications, particularly those involved with automatic gain control (AGC) or temperature compensation of multiple gain stages, typically found in microwave radio or test instrumentation architecture. Removable SMA connectors can be detached to allow direct connection of the module input/output pins to a microstrip or coplanar circuit.

FUNCTIONAL BLOCK DIAGRAM

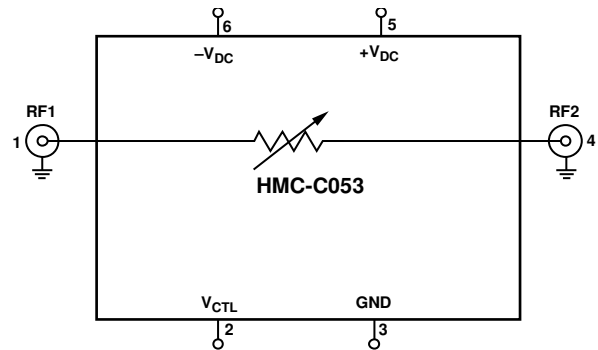

Figure 1.

TABLE OF CONTENTS

Features	1	ESD Caution.....	4
Applications.....	1	Pin Configuration and Function Descriptions.....	5
Functional Block Diagram	1	Interface Schematics	5
General Description	1	Typical Performance Characteristics	6
Revision History	2	Applications Information	8
Specifications.....	3	Outline Dimensions	9
Electrical Specifications.....	3	Ordering Guide	9
Absolute Maximum Ratings.....	4		

REVISION HISTORY

This Hittite Microwave Products data sheet has been reformatted to meet the styles and standards of Analog Devices, Inc.

9/2016—Rev. E to Rev. F

Changes to Supply Current Parameter, Table 1	3
--	---

10/2015—Rev. D to Rev. E

Updated Layout.....	Universal
Changes to Table 1.....	3
Added Figure 2.....	5
Changes to Table 3.....	5
Changes to Figure 7.....	6
Added Applications Information Section and Figure 14	8
Updated Outline Dimensions	9
Changes to Ordering Guide	9

SPECIFICATIONS

ELECTRICAL SPECIFICATIONS

$T_A = +25^\circ\text{C}$, $+V_{DC} = 5\text{ V}$, $-V_{DC} = -5\text{ V}$, and $V_{CTL} = 0\text{ V}$ to -3 V , unless otherwise noted.

Table 1.

Parameter	Min	Typ	Max	Unit	Test Conditions/Comments
INSERTION LOSS ($V_{CTL} = 0\text{ V}$)					
DC to 5 GHz		1.5		dB	
5 GHz to 10 GHz		1.9		dB	
10 GHz to 14 GHz		2.4		dB	
14 GHz to 20 GHz		4.0		dB	
ATTENUATION RANGE ($V_{CTL} = -2.9\text{ V}$)					
DC to 5 GHz	25	32		dB	
5 GHz to 10 GHz	27	33		dB	
10 GHz to 14 GHz	25	30		dB	
14 GHz to 20 GHz	21	26		dB	
RETURN LOSS AT RF1					
DC to 14 GHz		15		dB	
DC to 20 GHz		8		dB	
INPUT POWER FOR 0.25 dB COMPRESSION					Frequency = 0.5 GHz to 8.0 GHz
Minimum Attenuation		7		dBm	
Attenuation > 5 dB		-4		dBm	
INPUT THIRD-ORDER INTERCEPT POINT					Two-tone input power = 10 dBm each tone, frequency = 0.5 GHz to 16 GHz
Minimum Attenuation		22		dBm	
Attenuation > 10 dB		25		dBm	
SWITCHING CHARACTERISTICS					
t_{RISE}		111		ns	90% RF
t_{FALL}		83		ns	10% RF
t_{ON}		125		ns	50% V_{CTL} to 90% RF
t_{OFF}		103		ns	50% V_{CTL} to 10% RF
SUPPLY VOLTAGE AND CURRENT					$\pm V_{DC}$ range = $\pm 10\%$
Supply Voltage					
+ V_{DC}		5.0		V	
- V_{DC}		-5.0		V	
Supply Current					
+5.0 V dc		4.0	7.0	mA	
-5.0 V dc		-10.5	-14.0	mA	
CONTROL VOLTAGE					
Minimum Attenuation		0		V	
Maximum Attenuation		-2.9		V	

ABSOLUTE MAXIMUM RATINGS

Table 2.

Parameter	Rating
Control Voltage (V_{CTL})	-5 V dc to +1 V dc
Supply Voltage	
+ V_{DC}	16 V dc
- V_{DC}	-16 V dc
RF Input Power (0.5 GHz to 20 GHz)	18 dBm
Storage Temperature Range	-65°C to +150°C
Operating Temperature Range	-55°C to +85°C

Stresses at or above those listed under Absolute Maximum Ratings may cause permanent damage to the product. This is a stress rating only; functional operation of the product at these or any other conditions above those indicated in the operational section of this specification is not implied. Operation beyond the maximum operating conditions for extended periods may affect product reliability.

ESD CAUTION



ESD (electrostatic discharge) sensitive device. Charged devices and circuit boards can discharge without detection. Although this product features patented or proprietary protection circuitry, damage may occur on devices subjected to high energy ESD. Therefore, proper ESD precautions should be taken to avoid performance degradation or loss of functionality.

PIN CONFIGURATION AND FUNCTION DESCRIPTIONS

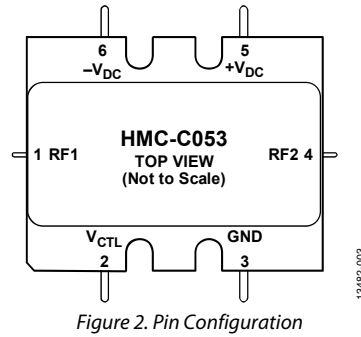

Figure 2. Pin Configuration

Table 3. Pin Function Descriptions

Pin No.	Mnemonic	Description
1	RF1	RF Input 1. This pin is dc-coupled and matched to 50 Ω. Blocking capacitors are required if the RF line potential is not equal to 0 V.
2	V _{CTL}	Control Input (Master).
3	GND	Ground. Package bottom has an exposed metal paddle that must also be connected to the printed circuit board (PCB) RF ground.
4	RF2	RF Input 2. This pin is dc-coupled and matched to 50 Ω. Blocking capacitors are required if the RF line potential is not equal to 0 V.
5	+V _{DC}	Positive Supply Voltage.
6	-V _{DC}	Negative Supply Voltage.

INTERFACE SCHEMATICS

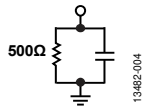

Figure 3. V_{CTL} Interface Schematic

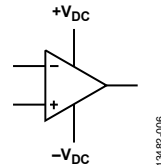

Figure 5. +V_{DC} and -V_{DC} Interface Schematic



Figure 4. GND Interface Schematic

TYPICAL PERFORMANCE CHARACTERISTICS

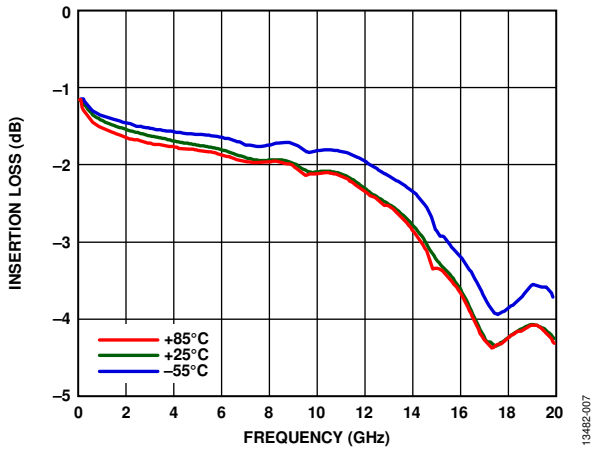

Figure 6. Insertion Loss vs. Frequency over Temperature

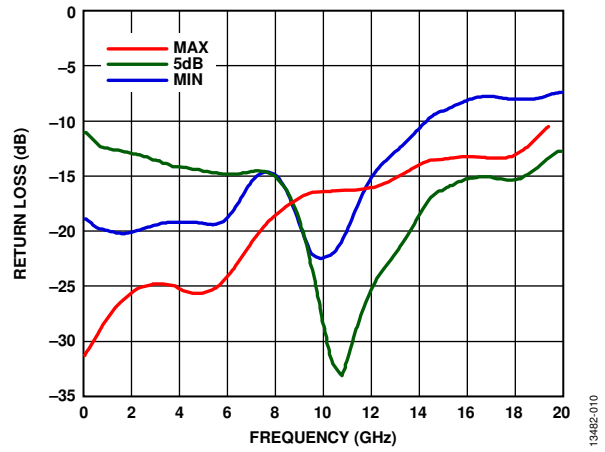

Figure 9. Return Loss RF1 vs. Frequency over Attenuation

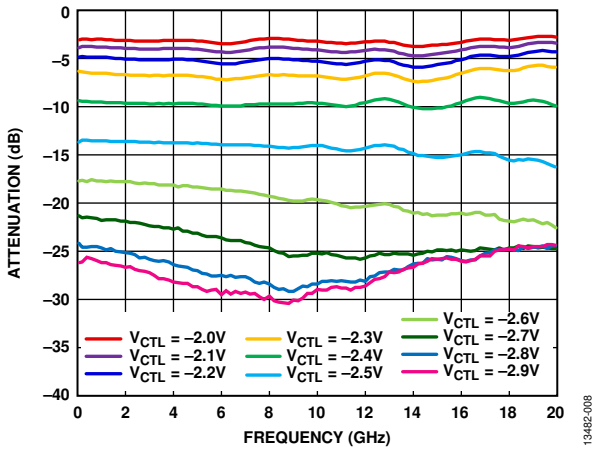

Figure 7. Relative Attenuation vs. Frequency

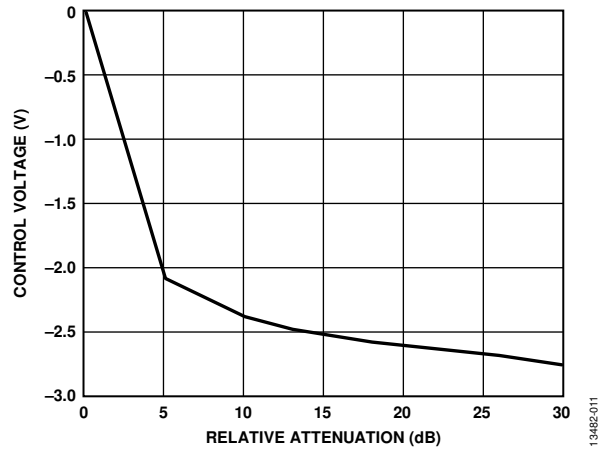

Figure 10. Relative Attenuation vs. Control Voltage at 10 GHz

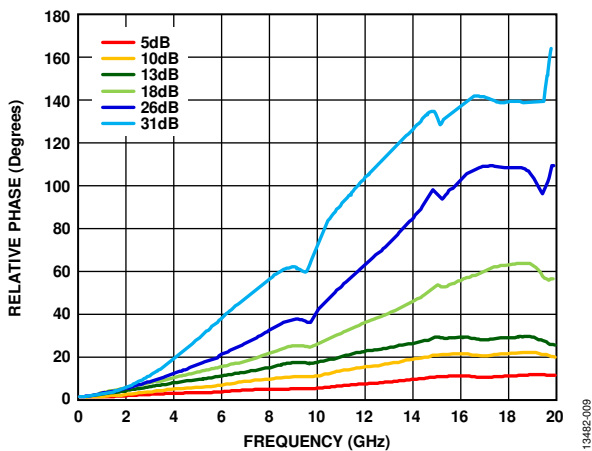

Figure 8. Relative Phase vs. Frequency

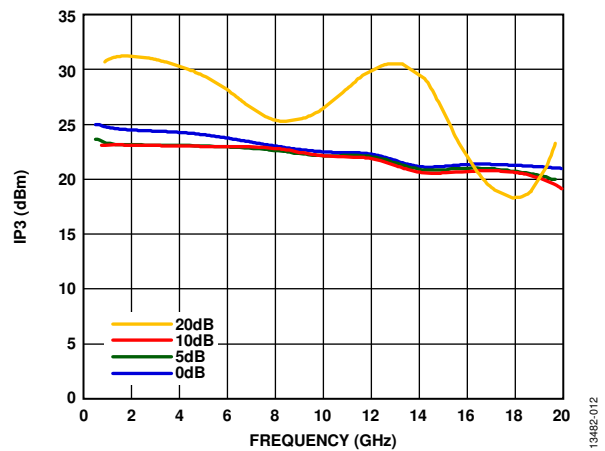

Figure 11. Input IP3 vs. Frequency over Attenuation

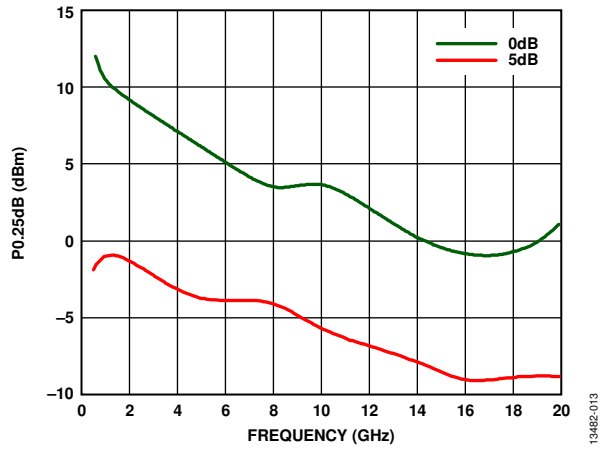

Figure 12. 0.25 dB Compression vs. Frequency over Attenuation

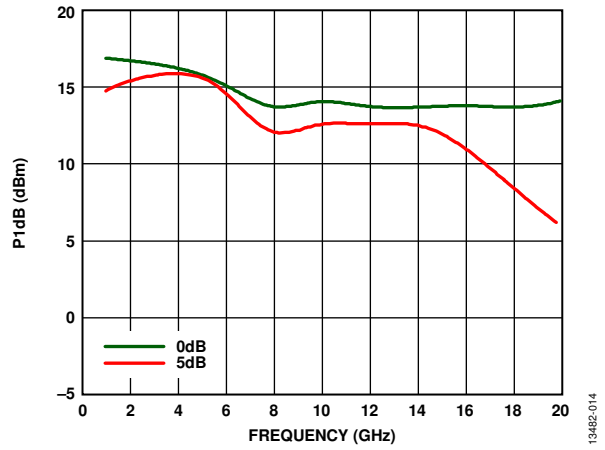
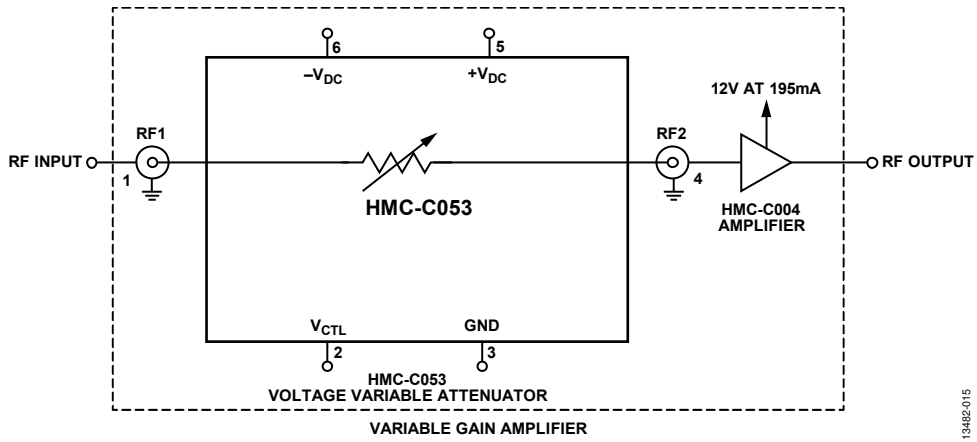

Figure 13. 1 dB Compression vs. Frequency over Attenuation

APPLICATIONS INFORMATION

In Figure 14, the HMC-C053 is used to make a variable gain amplifier. In this application circuit, the HMC-C053 varies the amplitude of the signal feeding the amplifier over a 30 dB

dynamic range. This type of circuit can be used to adjust the overall gain for temperature or frequency. This is only one of the many applications of the HMC-C053.



13482-015

OUTLINE DIMENSIONS

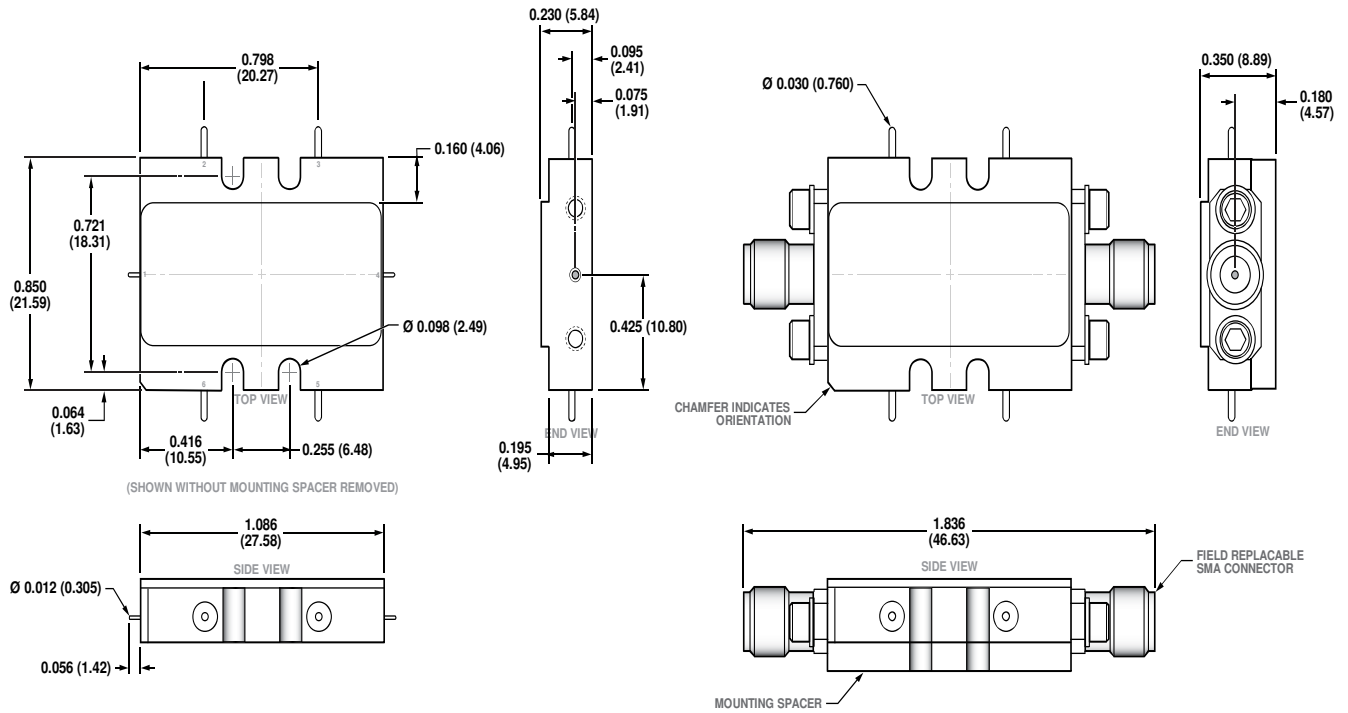

CONTROLLING DIMENSIONS ARE IN INCHES; MILLIMETER DIMENSIONS (IN PARENTHESES) ARE ROUNDED-OFF INCH EQUIVALENTS FOR REFERENCE ONLY AND ARE NOT APPROPRIATE FOR USE IN DESIGN.

Figure 15. 6-Lead Module with Connector Interface [MODULE] (HML-6-2)
Dimensions shown in inches (and millimeters)

ORDERING GUIDE

Model ¹	Temperature Range	Package Description	Package Option
HMC-C053	-55°C to +85°C	6-Lead Module with Connector Interface [MODULE]	HML-6-2

¹ The HMC-C053 is a RoHS compliant part.