

# OKI Semiconductor

**FEDD51V65165E-02**  
Issue Date: Aug. 28, 2002

## MD51V65165E

**4,194,304-Word × 16-Bit DYNAMIC RAM : FAST PAGE MODE TYPE WITH EDO**

### DESCRIPTION

The MD51V65165E is a 4,194,304-word × 16-bit dynamic RAM fabricated in Oki's silicon-gate CMOS technology. The MD51V65165E achieves high integration, high-speed operation, and low-power consumption because Oki manufactures the device in a quadruple-layer polysilicon/double-layer metal CMOS process. The MD51V65165E is available in a 50-pin plastic TSOP.

### FEATURES

- 4,194,304-word × 16-bit configuration
- Single 3.3V power supply, ±0.3V tolerance
- Input : LVTTL compatible, low input capacitance
- Output : LVTTL compatible, 3-state
- Refresh :
  - RAS only refresh : 4096 cycles/64ms
  - CAS before RAS refresh, hidden refresh : 4096 cycles/64ms
- Fast page mode with EDO, read modify write capability
- CAS before RAS refresh, hidden refresh, RAS-only refresh capability
- Packages
  - 50-pin 400mil plastic TSOP (TSOPII50-P-400-0.80-K) (Product : MD51V65165E-xxTA)  
xx indicates speed rank.

### PRODUCT FAMILY

Family	Access Time (Max.)				Cycle Time (Min.)	Power Dissipation	
	t <sub>RAC</sub>	t <sub>AA</sub>	t <sub>CAC</sub>	t <sub>OEA</sub>		Operating (Max.)	Standby (Max.)
MD51V65165E	50ns	25ns	13ns	13ns	84ns	504mW	1.8mW
	60ns	30ns	15ns	15ns	104ns	432mW	

**PIN CONFIGURATION (TOP VIEW)**

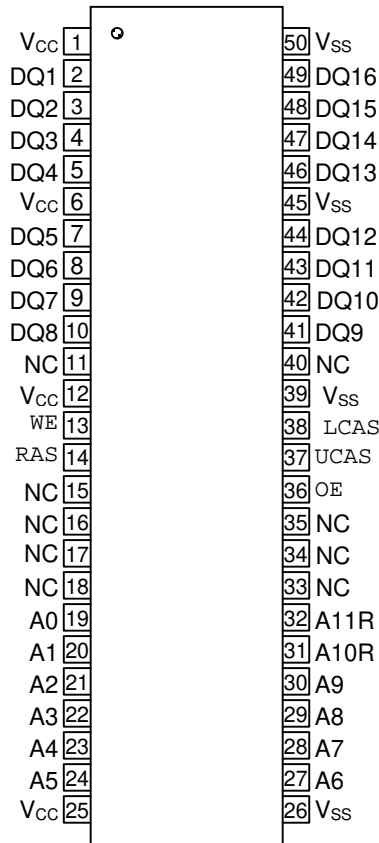

50-Pin Plastic TSOP  
(K Type)

Pin Name	Function
A0–A9, A10R, A11R	Address Input
RAS	Row Address Strobe
LCAS	Lower Byte Column Address Strobe
UCAS	Upper Byte Column Address Strobe
DQ1–DQ16	Data Input/Data Output
OE	Output Enable
WE	Write Enable
V <sub>CC</sub>	Power Supply (3.3V)
V <sub>SS</sub>	Ground (0V)
NC	No Connection

Note : The same power supply voltage must be provided to every V<sub>CC</sub> pin, and the same GND voltage level must be provided to every V<sub>SS</sub> pin.

**BLOCK DIAGRAM**

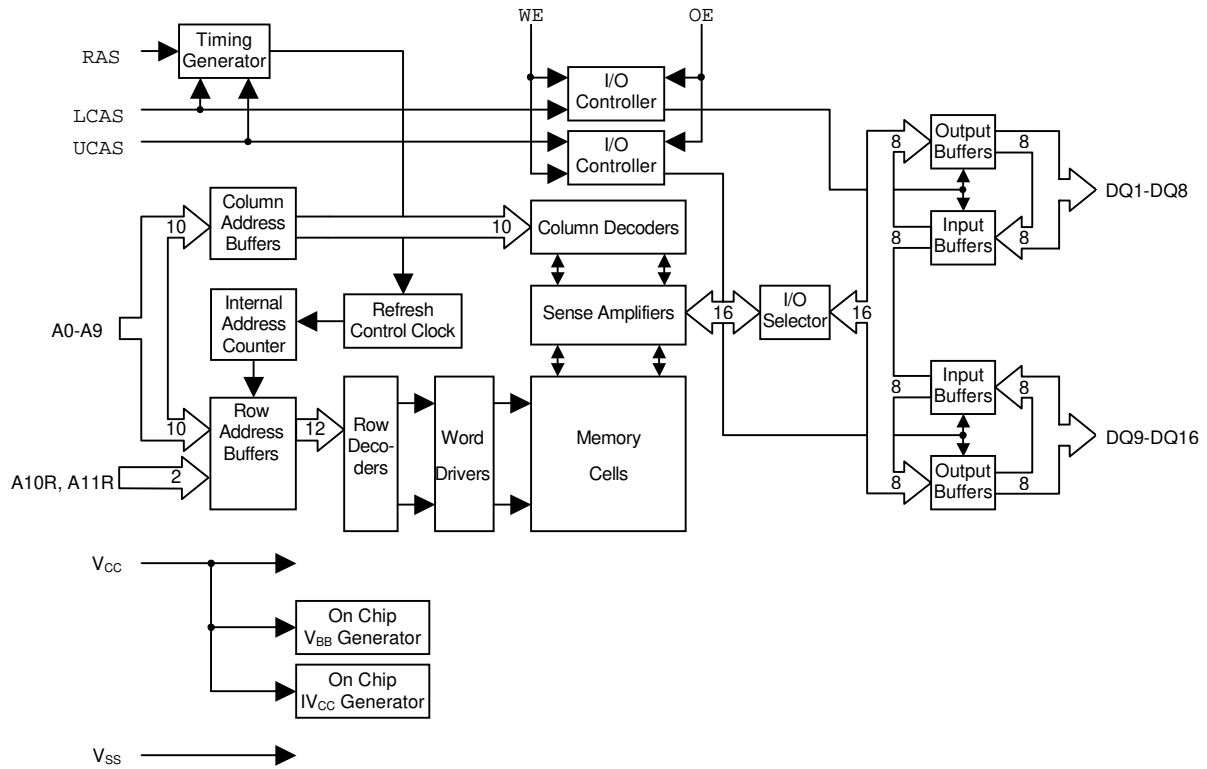

**FUNCTION TABLE**

Input Pin					DQ Pin		Function Mode
RAS	LCAS	UCAS	WE	OE	DQ1-DQ8	DQ9-DQ16	
H	*	*	*	*	High-Z	High-Z	Standby
L	H	H	*	*	High-Z	High-Z	Refresh
L	L	H	H	L	D <sub>OUT</sub>	High-Z	Lower Byte Read
L	H	L	H	L	High-Z	D <sub>OUT</sub>	Upper Byte Read
L	L	L	H	L	D <sub>OUT</sub>	D <sub>OUT</sub>	Word Read
L	L	H	L	H	D <sub>IN</sub>	Don't Care	Lower Byte Write
L	H	L	L	H	Don't Care	D <sub>IN</sub>	Upper Byte Write
L	L	L	L	H	D <sub>IN</sub>	D <sub>IN</sub>	Word Write
L	L	L	H	H	High-Z	High-Z	—

\* : "H" or "L"

**ELECTRICAL CHARACTERISTICS****ABSOLUTE MAXIMUM RATINGS**

Parameter	Symbol	Value	Unit
Voltage on Any Pin Relative to $V_{SS}$	$V_{IN}, V_{OUT}$	-0.5 to $V_{CC}+0.5$	V
Voltage $V_{CC}$ Supply relative to $V_{SS}$	$V_{CC}$	-0.5 to 4.6	V
Short Circuit Output Current	$I_{OS}$	50	mA
Power Dissipation	$P_{D^*}$	1	W
Operating Temperature	$T_{opr}$	0 to 70	°C
Storage Temperature	$T_{stg}$	-55 to 150	°C

\*:  $T_a = 25^{\circ}\text{C}$ **RECOMMENDED OPERATING CONDITIONS**

(Ta = 0 to 70°C)

Parameter	Symbol	Min.	Typ.	Max.	Unit
Power Supply Voltage	$V_{CC}$	3.0	3.3	3.6	V
	$V_{SS}$	0	0	0	V
Input High Voltage	$V_{IH}$	2.0	—	$V_{CC} + 0.3^{*1}$	V
Input Low Voltage	$V_{IL}$	$-0.3^{*2}$	—	0.8	V

Notes: \*1. The input voltage is  $V_{CC} + 1.0\text{V}$  when the pulse width is less than 20ns (the pulse width is with respect to the point at which  $V_{CC}$  is applied).

\*2. The input voltage is  $V_{SS} - 1.0\text{V}$  when the pulse width is less than 20ns (the pulse width respect to the point at which  $V_{SS}$  is applied).

**PIN CAPACITANCE**

(Vcc = 3.3V ± 0.3V, Ta = 25°C, f = 1 MHz)

Parameter	Symbol	Min.	Max.	Unit
Input Capacitance (A0 – A9, A10R, A11R)	$C_{IN1}$	—	5	pF
Input Capacitance (RAS, LCAS, UCAS, WE, OE)	$C_{IN2}$	—	7	pF
Output Capacitance (DQ1 - DQ16)	$C_{I/O}$	—	7	pF

## DC CHARACTERISTICS

(V<sub>CC</sub> = 3.3V ± 0.3V, Ta = 0 to 70°C)

Parameter	Symbol	Condition	MD51V65165 E-50		MD51V65165 E-60		Unit	Note
			Min.	Max.	Min.	Max.		
Output High Voltage	V <sub>OH</sub>	I <sub>OH</sub> = -2.0mA	2.4	V <sub>CC</sub>	2.4	V <sub>CC</sub>	V	
Output Low Voltage	V <sub>OL</sub>	I <sub>OL</sub> = 2mA	0	0.4	0	0.4	V	
Input Leakage Current	I <sub>LI</sub>	0V ≤ V <sub>I</sub> ≤ V <sub>CC</sub> +0.3V; All other pins not under test = 0V	- 10	10	- 10	10	μA	
Output Leakage Current	I <sub>LO</sub>	DQ disable 0V ≤ V <sub>O</sub> ≤ V <sub>CC</sub>	- 10	10	- 10	10	μA	
Average Power Supply Current (Operating)	I <sub>CC1</sub>	RAS, CAS cycling, t <sub>RC</sub> = Min.	—	140	—	120	mA	1,2
Power Supply Current (Standby)	I <sub>CC2</sub>	RAS, CAS = V <sub>IH</sub>	—	2	—	2	mA	1
		RAS, CAS ≥ V <sub>CC</sub> - 0.2V	—	0.5	—	0.5		
Average Power Supply Current (RAS-only Refresh)	I <sub>CC3</sub>	RAS cycling, CAS = V <sub>IH</sub> , t <sub>RC</sub> = Min.	—	140	—	120	mA	1,2
Power Supply Current (Standby)	I <sub>CC5</sub>	RAS = V <sub>IH</sub> , CAS = V <sub>IL</sub> , DQ = enable	—	5	—	5	mA	1
Average Power Supply Current (CAS before RAS Refresh)	I <sub>CC6</sub>	RAS = cycling, CAS before RAS	—	140	—	120	mA	1,2
Average Power Supply Current (Fast Page Mode)	I <sub>CC7</sub>	RAS = V <sub>IL</sub> , CAS cycling, t <sub>HPC</sub> = Min.	—	140	—	120	mA	1,3

Notes: 1. I<sub>CC</sub> Max. is specified as I<sub>CC</sub> for output open condition.2. The address can be changed once or less while RAS = V<sub>IL</sub>.3. The address can be changed once or less while CAS = V<sub>IH</sub>.

## AC CHARACTERISTICS (1/2)

(V<sub>CC</sub> = 3.3V ± 0.3V, Ta = 0 to 70°C) Note1,2,3

Parameter	Symbol	MD51V65165 E-50		MD51V65165 E-60		Unit	Note
		Min.	Max.	Min.	Max.		
Random Read or Write Cycle Time	t <sub>RC</sub>	84	—	104	—	ns	
Read Modify Write Cycle Time	t <sub>RWC</sub>	110	—	135	—	ns	
Fast Page Mode Cycle Time	t <sub>HPC</sub>	20	—	25	—	ns	
Fast Page Mode Read Modify Write Cycle Time	t <sub>HPRWC</sub>	58	—	68	—	ns	
Access Time from RAS	t <sub>RAC</sub>	—	50	—	60	ns	4, 5, 6
Access Time from CAS	t <sub>CAC</sub>	—	13	—	15	ns	4,5
Access Time from Column Address	t <sub>AA</sub>	—	25	—	30	ns	4,6
Access Time from CAS Precharge	t <sub>CPA</sub>	—	30	—	35	ns	4,13
Access Time from OE	t <sub>OEa</sub>	—	13	—	15	ns	4
Output Low Impedance Time from CAS	t <sub>CLZ</sub>	0	—	0	—	ns	4
Data Output Hold After CAS Low	t <sub>DOH</sub>	5	—	5	—	ns	
CAS to Data Output Buffer Turn-off Delay Time	t <sub>CEZ</sub>	0	13	0	15	ns	7,8
RAS to Data Output Buffer Turn-off Delay Time	t <sub>REZ</sub>	0	13	0	15	ns	7,8
OE to Data Output Buffer Turn-off Delay Time	t <sub>OEZ</sub>	0	13	0	15	ns	7
WE to Data Output Buffer Turn-off Delay Time	t <sub>WEZ</sub>	0	13	0	15	ns	7
Transition Time	t <sub>T</sub>	1	50	1	50	ns	3
Refresh Period	t <sub>REF</sub>	—	64	—	64	ms	
RAS Precharge Time	t <sub>RP</sub>	30	—	40	—	ns	
RAS Pulse Width	t <sub>RAS</sub>	50	10,000	60	10,000	ns	
RAS Pulse Width (Fast Page Mode with EDO)	t <sub>RASP</sub>	50	100,000	60	100,000	ns	
RAS Hold Time	t <sub>RSH</sub>	7	—	10	—	ns	
RAS Hold Time referenced to OE	t <sub>ROH</sub>	7	—	10	—	ns	
CAS Precharge Time (Fast Page Mode with EDO)	t <sub>CP</sub>	7	—	10	—	ns	15
CAS Pulse Width	t <sub>CAS</sub>	7	10,000	10	10,000	ns	
CAS Hold Time	t <sub>CSH</sub>	35	—	40	—	ns	
CAS to RAS Precharge Time	t <sub>CRP</sub>	5	—	5	—	ns	13
RAS Hold Time from CAS Precharge	t <sub>RHCP</sub>	30	—	35	—	ns	13
OE Hold Time from CAS (DQ Disable)	t <sub>CHO</sub>	5	—	5	—	ns	

## AC CHARACTERISTICS (2/2)

(V<sub>CC</sub> = 3.3V ± 0.3V, T<sub>a</sub> = 0 to 70°C) Note1,2,3

Parameter	Symbol	MD51V65165 E-50		MD51V65165 E-60		Unit	Note
		Min.	Max.	Min.	Max.		
RAS to CAS Delay Time	t <sub>RCD</sub>	11	37	14	45	ns	5
RAS to Column Address Delay Time	t <sub>RAD</sub>	9	25	12	30	ns	6
Row Address Set-up Time	t <sub>ASR</sub>	0	—	0	—	ns	
Row Address Hold Time	t <sub>RAH</sub>	7	—	10	—	ns	
Column Address Set-up Time	t <sub>ASC</sub>	0	—	0	—	ns	12
Column Address Hold Time	t <sub>CAH</sub>	7	—	10	—	ns	12
Column Address to RAS Lead Time	t <sub>RAL</sub>	25	—	30	—	ns	
Read Command Set-up Time	t <sub>RCS</sub>	0	—	0	—	ns	12
Read Command Hold Time	t <sub>RCH</sub>	0	—	0	—	ns	9,12
Read Command Hold Time referenced to RAS	t <sub>RRH</sub>	0	—	0	—	ns	9
Write Command Set-up Time	t <sub>WCS</sub>	0	—	0	—	ns	10,12
Write Command Hold Time	t <sub>WCH</sub>	7	—	10	—	ns	12
Write Command Pulse Width	t <sub>Wp</sub>	7	—	10	—	ns	
WE Pulse Width (DQ Disable)	t <sub>WPE</sub>	7	—	10	—	ns	
OE Command Hold Time	t <sub>OEh</sub>	7	—	10	—	ns	
OE Precharge Time	t <sub>OEP</sub>	7	—	10	—	ns	
OE Command Hold Time	t <sub>OCH</sub>	7	—	10	—	ns	
Write Command to RAS Lead Time	t <sub>RWL</sub>	7	—	10	—	ns	
Write Command to CAS Lead Time	t <sub>CWL</sub>	7	—	10	—	ns	14
Data-in Set-up Time	t <sub>DS</sub>	0	—	0	—	ns	11,12
Data-in Hold Time	t <sub>DH</sub>	7	—	10	—	ns	11,12
OE to Data-in Delay Time	t <sub>OED</sub>	13	—	15	—	ns	
CAS to WE Delay Time	t <sub>CWD</sub>	30	—	34	—	ns	10
Column Address to WE Delay Time	t <sub>AWD</sub>	42	—	49	—	ns	10
RAS to WE Delay Time	t <sub>RWD</sub>	67	—	79	—	ns	10
CAS Precharge WE Delay Time	t <sub>CPWD</sub>	47	—	54	—	ns	10
CAS Active Delay Time from RAS Precharge	t <sub>RPC</sub>	5	—	5	—	ns	12
RAS to CAS Set-up Time (CAS before RAS)	t <sub>CSR</sub>	5	—	5	—	ns	12
RAS to CAS Hold Time(CAS before RAS)	t <sub>CHR</sub>	10	—	10	—	ns	13
WE to RAS Hold Time(CAS before RAS)	t <sub>WRP</sub>	10	—	10	—	ns	
WE Hold Time(CAS before RAS)	t <sub>WRH</sub>	10	—	10	—	ns	

- Notes:
1. A start-up delay of 200 $\mu$ s is required after power-up, followed by a minimum of eight initialization cycles (RAS-only refresh or CAS before RAS refresh) before proper device operation is achieved.
  2. The AC characteristics assume  $t_T = 2$ ns.
  3.  $V_{IH}$  (Min.) and  $V_{IL}$  (Max.) are reference levels for measuring input timing signals. Transition times ( $t_T$ ) are measured between  $V_{IH}$  and  $V_{IL}$ .
  4. This parameter is measured with a load circuit equivalent to 1 TTL load and 100pF. The output timing reference levels are  $V_{OH}=2.0$  and  $V_{OL}=0.8$ V.
  5. Operation within the  $t_{RCD}$  (Max.) limit ensures that  $t_{RAC}$  (Max.) can be met.  $t_{RCD}$  (Max.) is specified as a reference point only. If  $t_{RCD}$  is greater than the specified  $t_{RCD}$  (Max.) limit, then the access time is controlled by  $t_{CAC}$ .
  6. Operation within the  $t_{RAD}$  (Max.) limit ensures that  $t_{RAC}$  (Max.) can be met.  $t_{RAD}$  (Max.) is specified as a reference point only. If  $t_{RAD}$  is greater than the specified  $t_{RAD}$  (Max.) limit, then the access time is controlled by  $t_{AA}$ .
  7.  $t_{CEZ}$  (Max.),  $t_{REZ}$  (Max.),  $t_{WEZ}$  (Max.), and  $t_{OEZ}$  (Max.) define the time at which the output achieved the open circuit condition and are not referenced to output voltage levels.
  8.  $t_{CEZ}$ , and  $t_{REZ}$  must be satisfied for open circuit condition.
  9.  $t_{RCH}$  or  $t_{RRH}$  must be satisfied for a read cycle.
  10.  $t_{WCS}$ ,  $t_{CWD}$ ,  $t_{RWD}$ ,  $t_{AWD}$  and  $t_{CPWD}$  are not restrictive operating parameters. They are included in the data sheet as electrical characteristics only. If  $t_{WCS} \geq t_{WCS}$  (Min.), then the cycle is an early write cycle and the data out will remain open circuit (high impedance) throughout the entire cycle. If  $t_{CWD} \geq t_{CWD}$  (Min.),  $t_{RWD} \geq t_{RWD}$ (Min.),  $t_{AWD} \geq t_{AWD}$  (Min.) and  $t_{CPWD} \geq t_{CPWD}$  (Min.), then the cycle is a read modify write cycle and data out will contain data read from the selected cell; if neither of the above sets of conditions is satisfied, then the condition of the data out (at access time) is indeterminate.
  11. These parameters are referenced to the UCAS and LCAS, leading edges in an early write cycle, and to the WE leading edge in an OE control write cycle, or a read modify write cycle.
  12. These parameters are determined by the falling edge of either UCAS or LCAS, whichever is earlier.
  13. These parameters are determined by the rising edge of either UCAS or LCAS, whichever is later.
  14.  $t_{CWL}$  should be satisfied by both UCAS and LCAS.
  15.  $t_{CP}$  is determined by the time both UCAS and LCAS are high.



TIMING CHART

Read Cycle

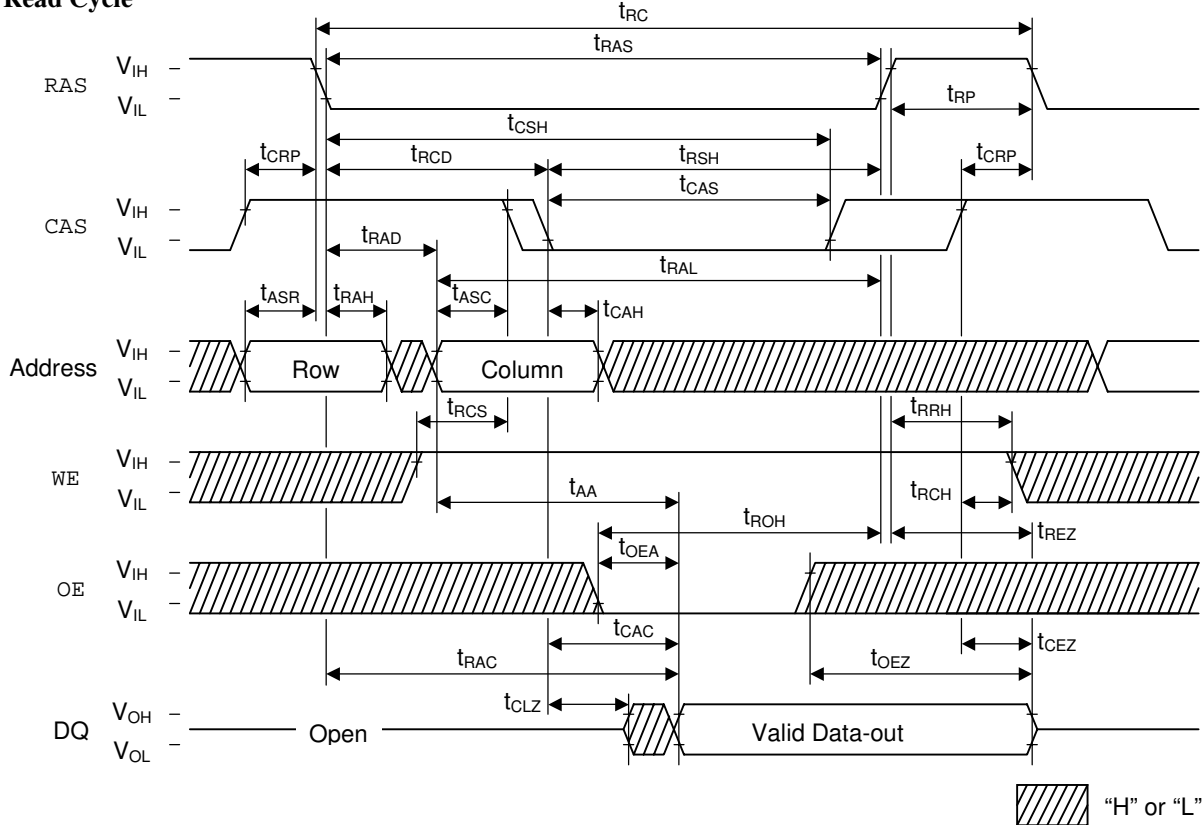

Write Cycle (Early Write)

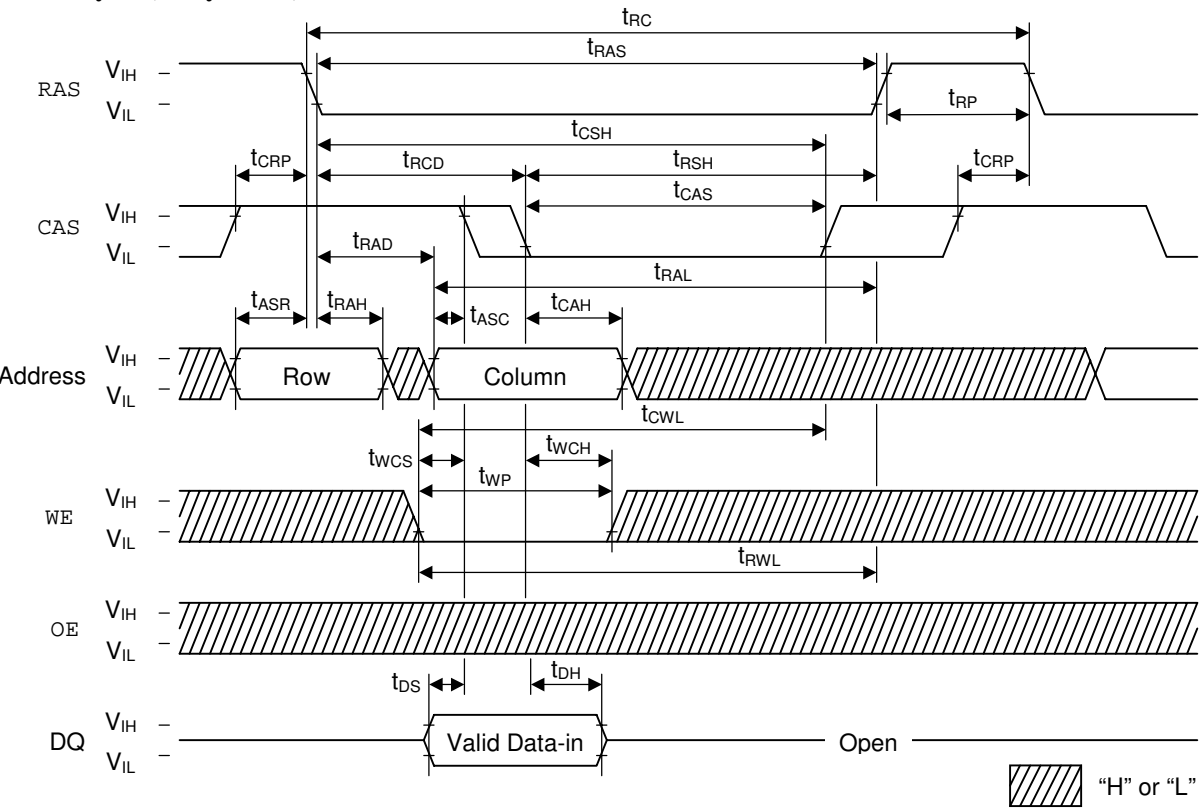

Read Modify Write Cycle

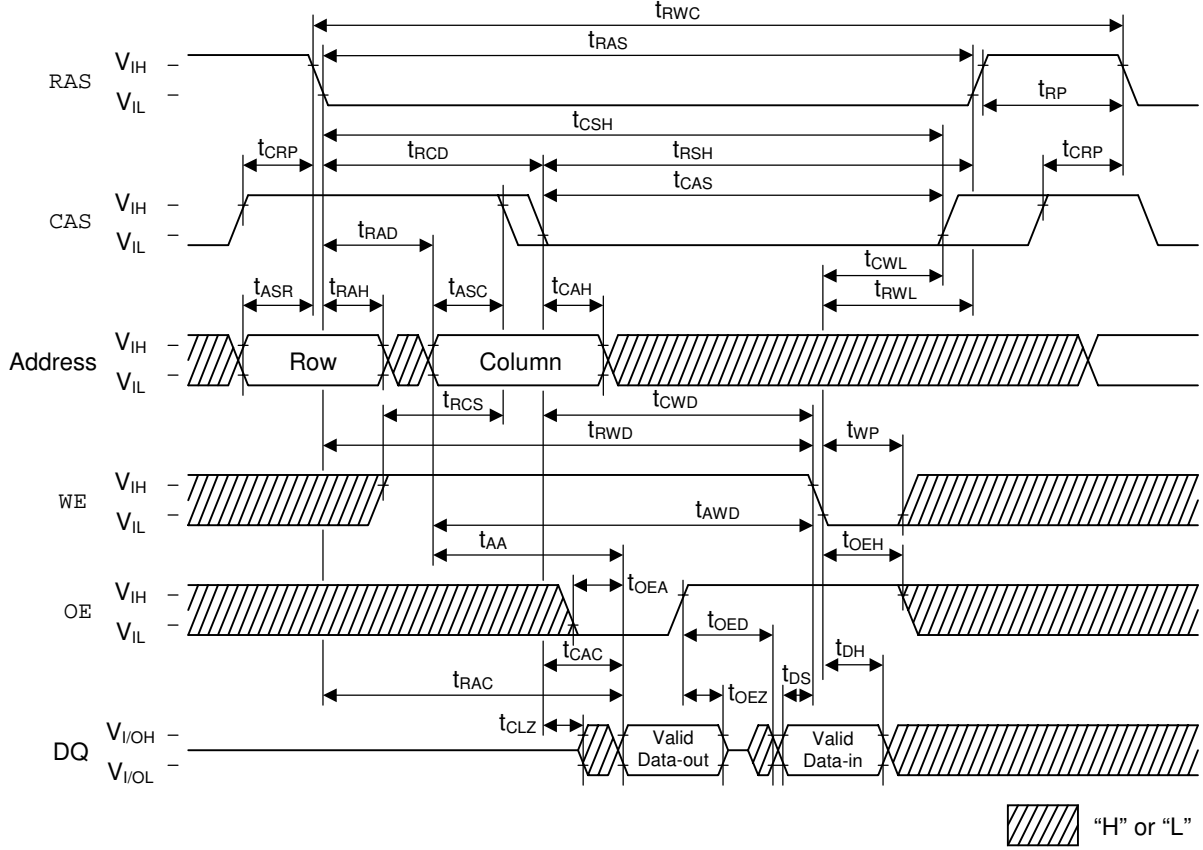

Fast Page Mode Read Cycle (Part-1)

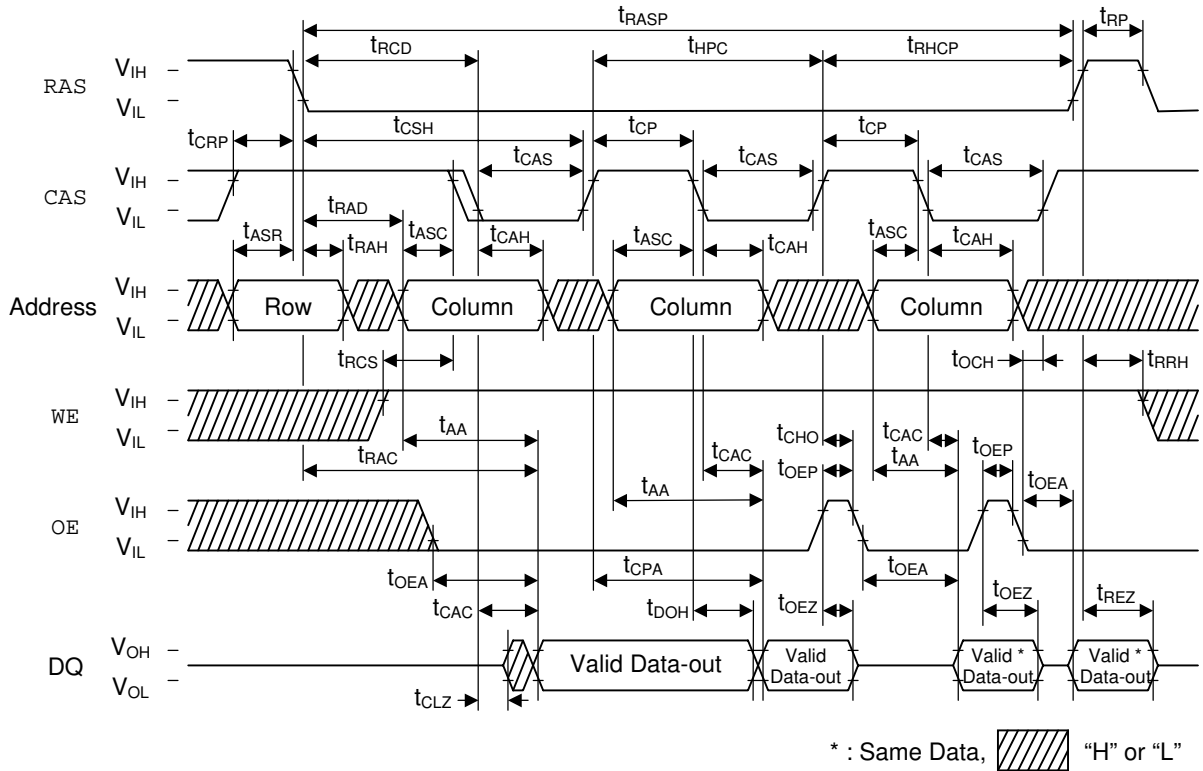

Fast Page Mode Read Cycle (Part-2)

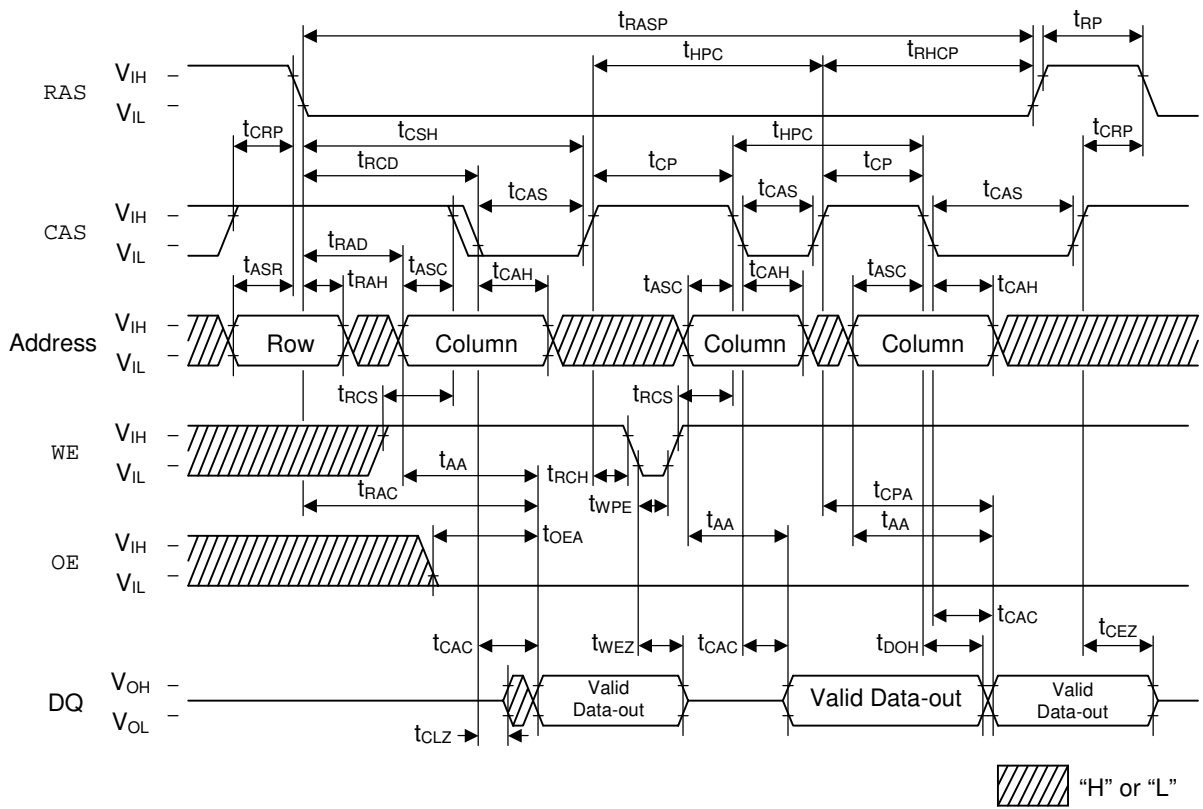

Fast Page Mode Write Cycle (Early Write)

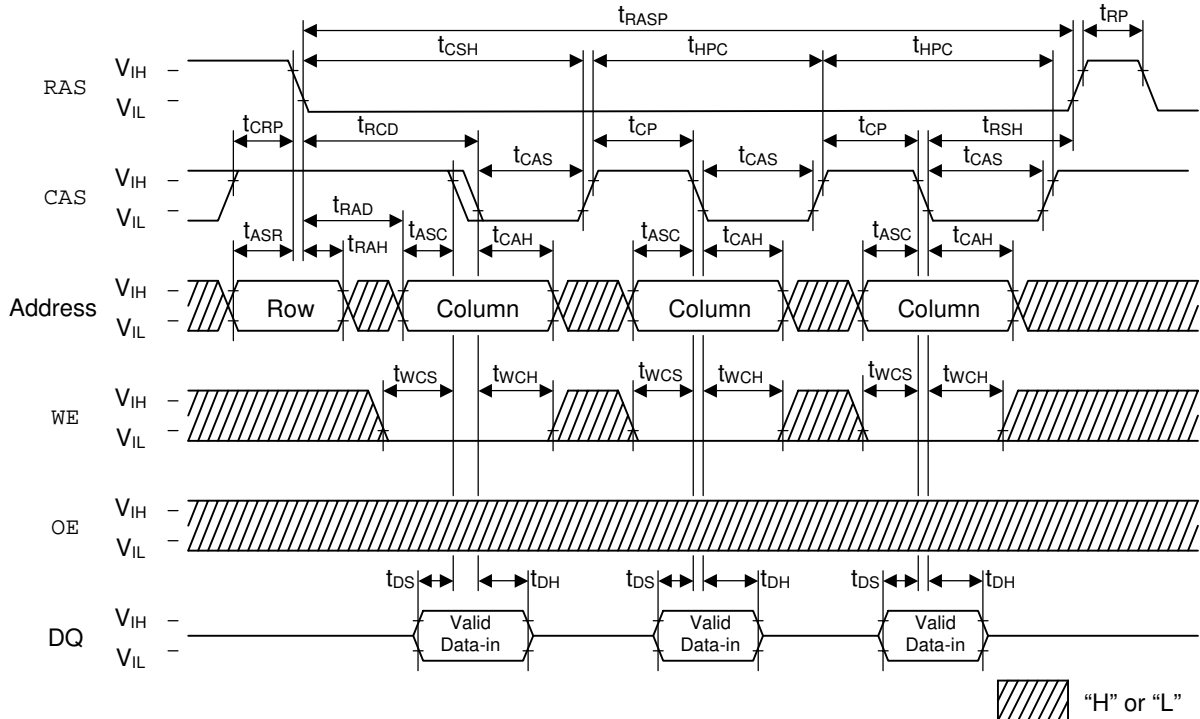

Fast Page Mode Read Modify Write Cycle

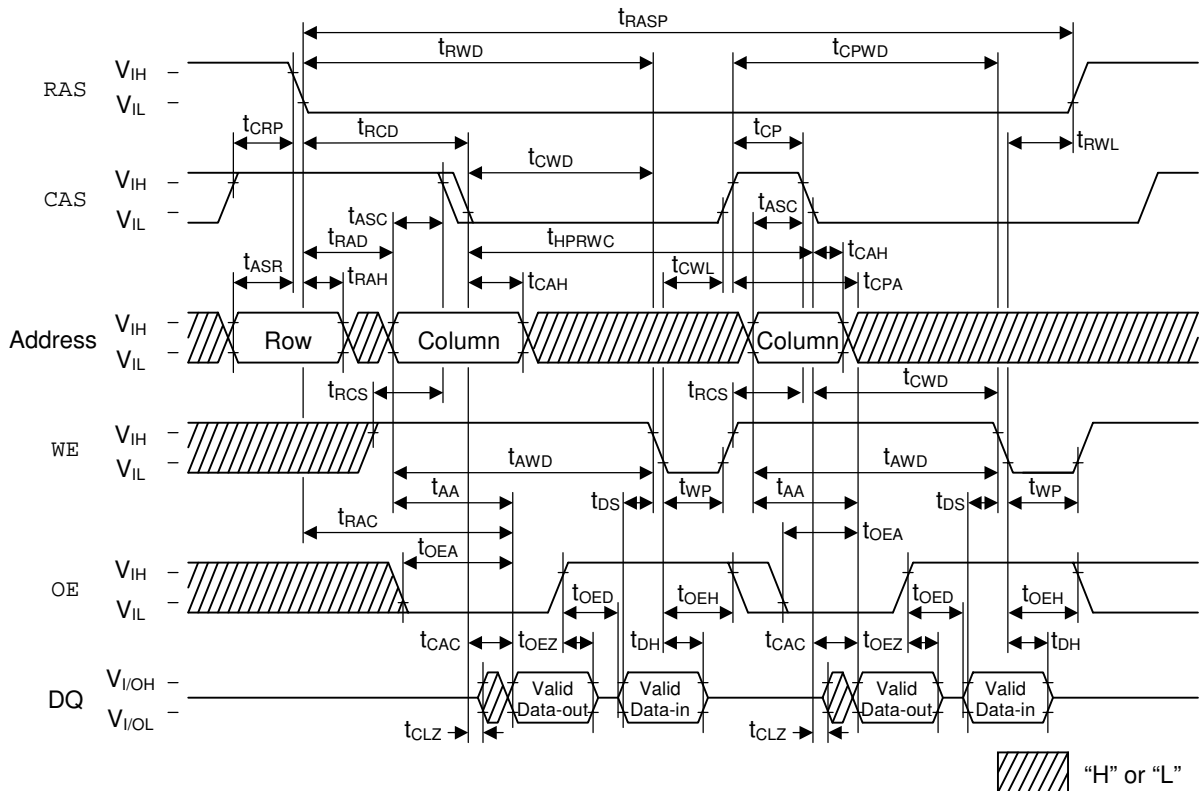

**RAS-only Refresh Cycle**

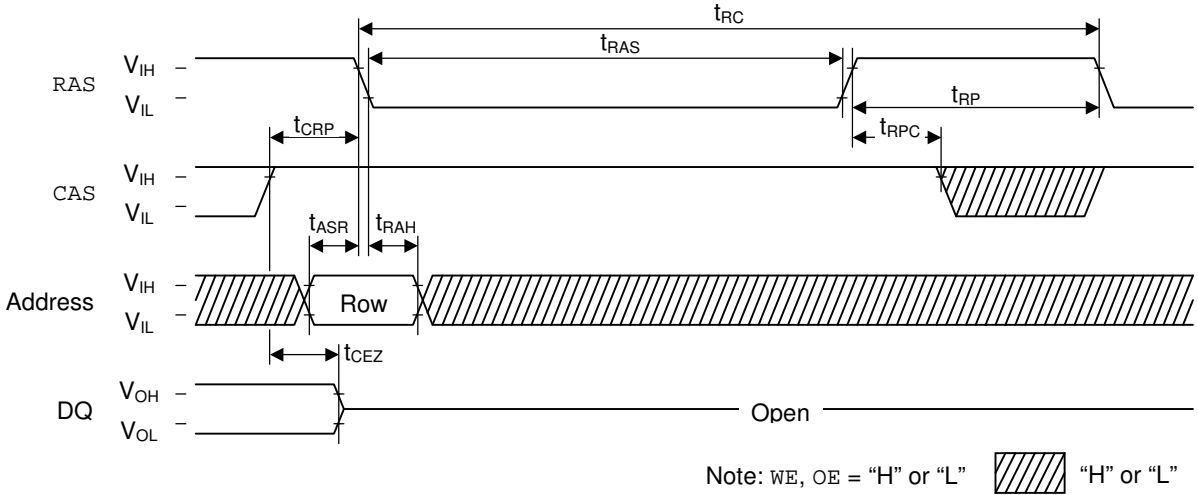

**CAS before RAS Refresh Cycle**

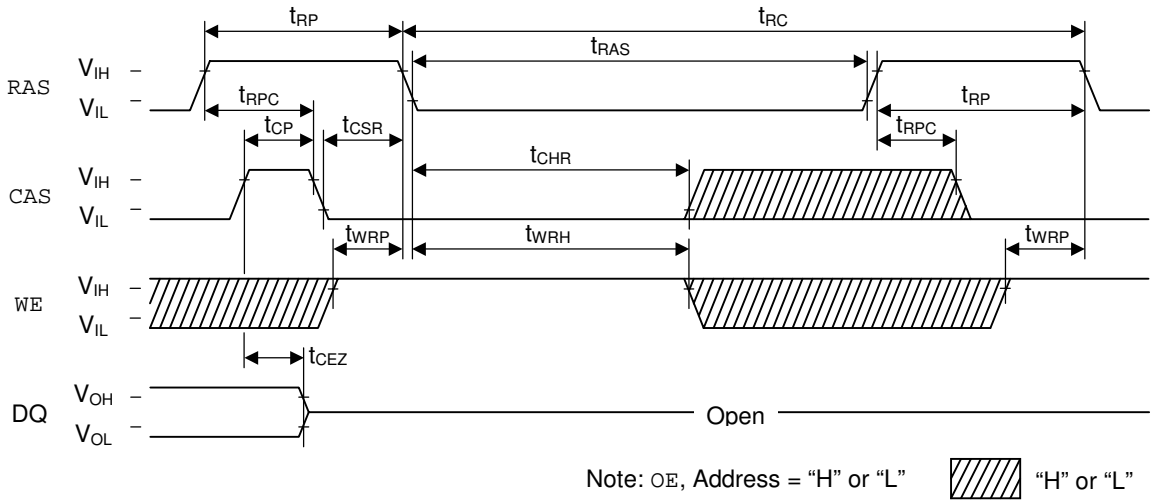



**REVISION HISTORY**

Document No.	Date	Page		Description
		Previous Edition	Current Edition	
FEDD51V65165E-01	Jan., 2002	–	–	Final edition 1
FEDD51V65165E-02	Aug., 2002	1, 2	1, 2	Deleted SOJ package

**NOTICE**

1. The information contained herein can change without notice owing to product and/or technical improvements. Before using the product, please make sure that the information being referred to is up-to-date.
2. The outline of action and examples for application circuits described herein have been chosen as an explanation for the standard action and performance of the product. When planning to use the product, please ensure that the external conditions are reflected in the actual circuit, assembly, and program designs.
3. When designing your product, please use our product below the specified maximum ratings and within the specified operating ranges including, but not limited to, operating voltage, power dissipation, and operating temperature.
4. **Oki assumes no responsibility or liability whatsoever for any failure or unusual or unexpected operation resulting from misuse, neglect, improper installation, repair, alteration or accident, improper handling, or unusual physical or electrical stress including, but not limited to, exposure to parameters beyond the specified maximum ratings or operation outside the specified operating range.**
5. Neither indemnity against nor license of a third party's industrial and intellectual property right, etc. is granted by us in connection with the use of the product and/or the information and drawings contained herein. No responsibility is assumed by us for any infringement of a third party's right which may result from the use thereof.
6. The products listed in this document are intended for use in general electronics equipment for commercial applications (e.g., office automation, communication equipment, measurement equipment, consumer electronics, etc.). These products are not authorized for use in any system or application that requires special or enhanced quality and reliability characteristics nor in any system or application where the failure of such system or application may result in the loss or damage of property, or death or injury to humans. Such applications include, but are not limited to, traffic and automotive equipment, safety devices, aerospace equipment, nuclear power control, medical equipment, and life-support systems.
7. Certain products in this document may need government approval before they can be exported to particular countries. The purchaser assumes the responsibility of determining the legality of export of these products and will take appropriate and necessary steps at their own expense for these.
8. No part of the contents contained herein may be reprinted or reproduced without our prior permission.

Copyright 2002 Oki Electric Industry Co., Ltd.