

Pb THIS PRODUCT MANUFACTURED WITH LEAD-FREE PROCESSING

DESIGNED & DIMENSIONED IN MILLIMETERS [INCHES]

SCRES-X-XX.XX-XX-C5E

DO NOT SCALE FROM THIS PRINT

PLATING SPECIFICATION

-G: .000050" GOLD ON CONTACT AREAS, NICKEL ON SHELLS

END OPTION

-D: DOUBLE ENDED (ONE END SEALED) (SEE FIG.1, SHT. 1)
-BC: BLUNT CUT (SEE FIG.2, SHT. 2)

LENGTH

-XX.XX (IN METERS) (0.17M MIN - 50.00M MAX)

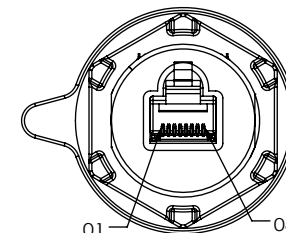
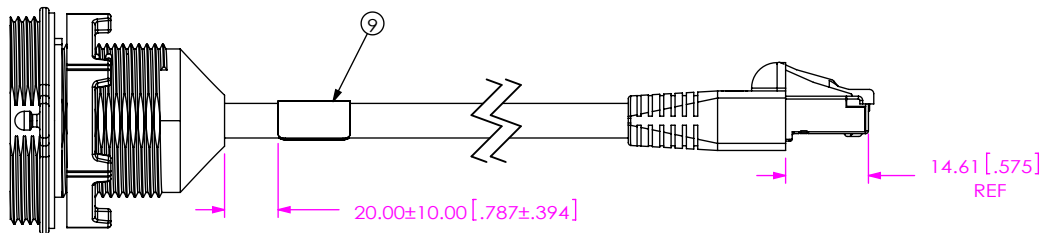
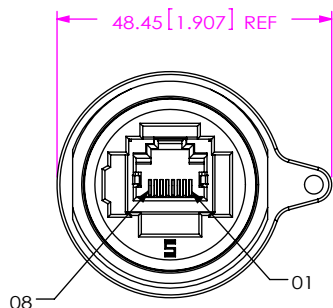
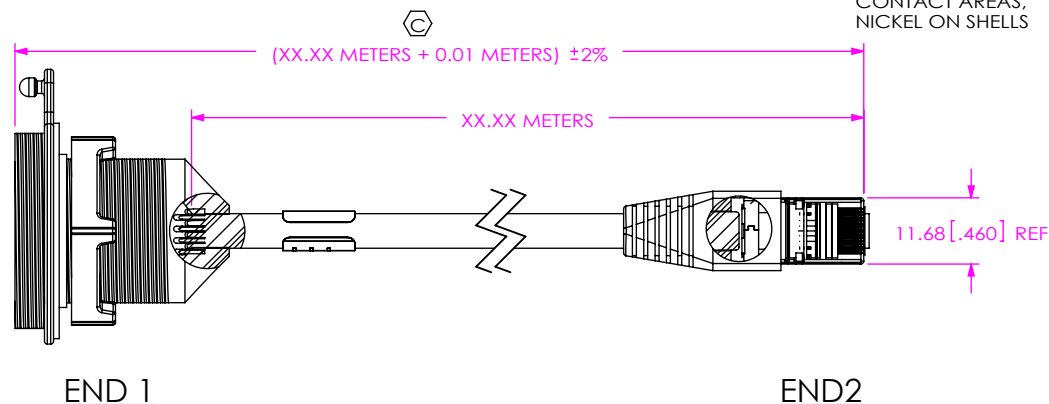

FIG 1
SCRES-G-XX.XX-D-C5E

NOTES:

1. REPRESENTS A CRITICAL DIMENSION.
2. CABLE LENGTH EQUALS OR LESS THAN 1.0 METER, ASSEMBLY TO BE 100% TESTED TO CAT5e; CABLE LENGTH EXCEEDS 1.0 METER, ASSEMBLY TO BE 100% TESTED TO CAT5; AFTER FINAL ELECTRICAL TEST, LABELED. FOR BLUNT CUT OPTION, A LABEL WILL BE APPLIED TO BOTH ENDS.
3. NOTE DELETED.
4. PANEL THICKNESS: 0.8[.03] - 5.2[.20].
5. PANEL NUT TORQUE SPECIFICATION: 12 IN-LB.
6. PART MUST SCREW INTO SAMTEC PART # SCN-17-01.
7. PART MUST SCREW INTO SAMTEC PART # SPN-17-01
8. FLAT REQUIRED AT PARTING LINE OF CAMS TO AVOID DRAGGING THREADS.
9. NOTE DELETED.
10. ALL IDENTIFICATION MARKS MUST NOT STAND GREATER THAN 0.051 [.002] OFF THE SURFACE OF THE PART.
11. MOLD TO BE INSERTED TO ACCEPT DIFFERENT CABLE DIAMETERS.
12. ALL EJECTOR PIN AND GATE LOCATIONS MUST BE APPROVED BY SAMTEC PRODUCT ENGINEERING.
13. ANY ADDITIONAL VOIDING AND/OR MODIFICATIONS TO VOIDING MUST BE APPROVED BY SAMTEC PRODUCT ENGINEERING.
14. SAMTEC LOGO SHALL APPEAR ON SURFACE SHOWN, APPROXIMATELY 1.88 X 3.00.
15. COMPONENTS OF ASSEMBLY TO BE INSPECTED USING COMPONENT PRINTS.
16. ASSEMBLY TO BE PACKAGED IN BULK.
17. NOTE DELETED.

SCRES-G-XX-XX-D-C5E BOM			
ITEM NO.	PART NUMBER	QTY	DESCRIPTION
1	ECA-02-02	XX.X	CABLE
2	MODS-A-8P8C-E-01-S-C5	1	CONNECTOR
3	PCB-101555-01	1	PCB
4	MD-PTC-RF-640-BK	1	PREMOLD
5	MD-NYL-ZY-80G14-BK	1	OVERMOLD
6	OR-17-01	1	O-RING
7	SPG-17-01	1	GASKET
8	SPN-17-01	1	NUT
9	LABEL-ET	1	LABEL
10	ETHB-02	1	ETHERNET BOOT
11	MODP-01-8P8C-S-01	1	CONNECTOR

UNLESS OTHERWISE SPECIFIED, DIMENSIONS ARE IN MILLIMETERS.
TOLERANCES ARE:
DECIMALS ANGLES
X.X: ±0.35[.014] 2°
X.XX: ±0.25[.010]
X.XXX: ±0.15[.0060]

PROPRIETARY NOTE

THIS DOCUMENT CONTAINS CONFIDENTIAL AND PROPRIETARY INFORMATION AND ALL DESIGN, MANUFACTURING, REPRODUCTION, USE, PATENT RIGHTS AND SALES RIGHTS ARE EXPRESSLY RESERVED BY SAMTEC, INC. THIS DOCUMENT SHALL NOT BE DISCLOSED, IN WHOLE OR PART, TO ANY UNAUTHORIZED PERSON OR ENTITY NOR REPRODUCED, TRANSFERRED OR INCORPORATED IN ANY OTHER PROJECT IN ANY MANNER WITHOUT THE EXPRESS WRITTEN CONSENT OF SAMTEC, INC.



520 PARK EAST BLVD, NEW ALBANY, IN 47150
PHONE: 812-944-6733 FAX: 812-948-5047
e-Mail: info@SAMTEC.com code: 55322

MATERIAL: DO NOT SCALE DRAWING SHEET SCALE: 1:1.53846
CABLE: PVC, COPPER
CONNECTOR: PBT, COPPER ALLOY
O-RING: SILICONE
PCB: FR4, COPPER
OVERMOLD, NUT: NYLON
PREMOLD: TPE
F:\DWG\MISC\MKTG\SCRES-X-XX.XX-XX-C5E-MKT.SLDDRW

DESCRIPTION:
SEALED CIRCULAR RECEPTACLE, ETHERNET
DWG. NO.
SCRES-X-XX.XX-XX-C5E
BY: CHADP 3/17/2009 SHEET 1 OF 6

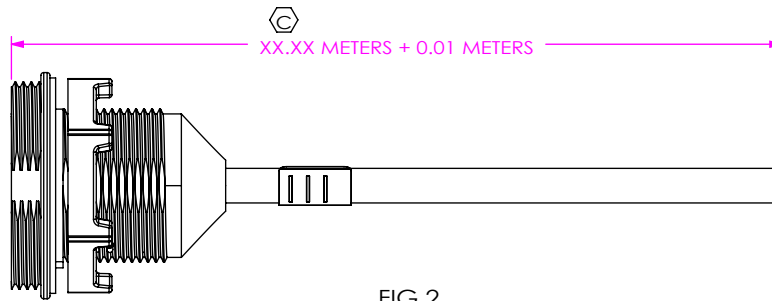
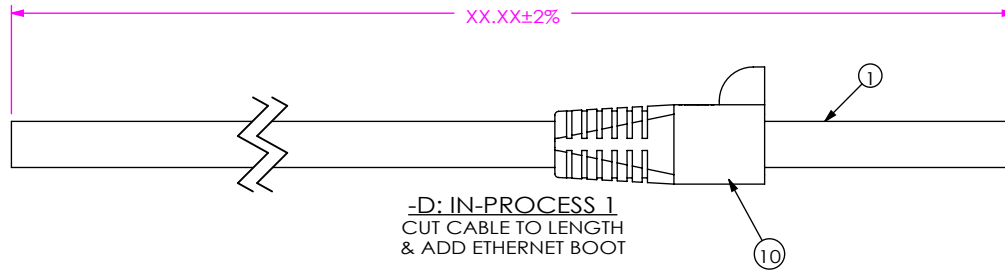
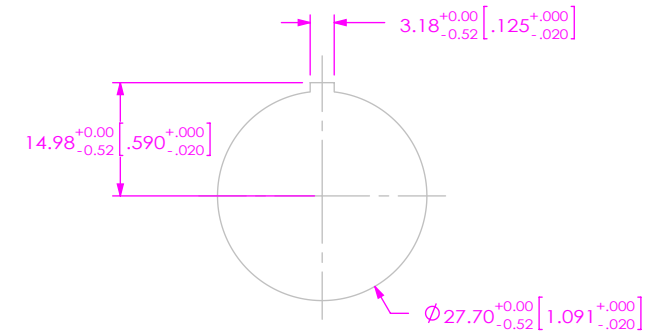

FIG 2
SCRES-G-XX.XX-BC-C5E
(SAME AS FIG 1 UNLESS OTHERWISE STATED)

SCRES-G-XX.XX-BC-C5E BOM			
ITEM NO.	PART NUMBER	QTY	DESCRIPTION
1	ECA-02-02	XX.X	CABLE
2	MODS-A-8P8C-E-01-S-C5	1	CONNECTOR
3	PCB-101555-01	1	PCB
4	MD-PTC-RF-640-BK	1	PREMOLD
5	MD-NYL-ZY-80G14-BK	1	OVERMOLD
6	OR-17-01	1	O-RING
7	SPG-17-01	1	GASKET
8	SPN-17-01	1	NUT
9	LABEL-ET	1	LABEL



-D: IN-PROCESS 1
CUT CABLE TO LENGTH
& ADD ETHERNET BOOT



RECOMMENDED PANEL HOLE
(SEE NOTE 4)

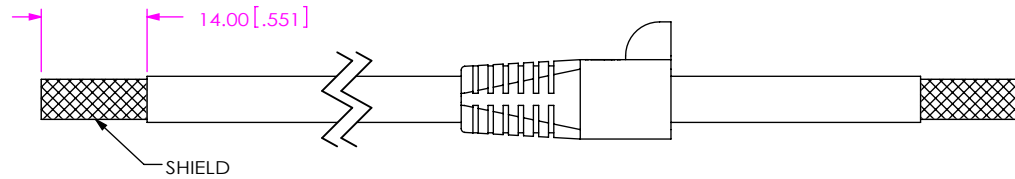

-D: IN-PROCESS 2
STRIP OUTER JACKET TO DIMENSION SHOWN

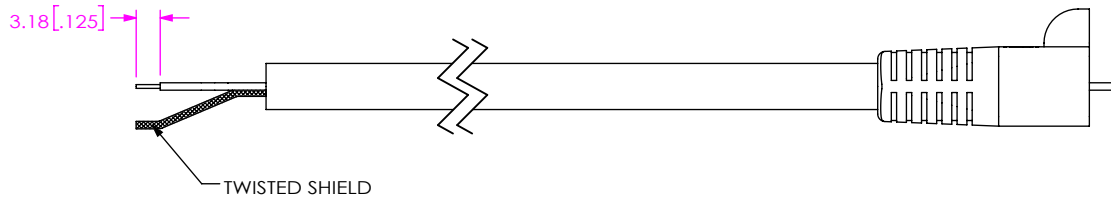

-D: IN-PROCESS 3
END 1: TWIST SHIELD TO FORM SINGLE CONDUCTOR.
STRIP INDIVIDUAL WIRES TO DIMENSION SHOWN & TIN DIP
END 2: FOLD BACK SHIELD

PROPRIETARY NOTE
THIS DOCUMENT CONTAINS CONFIDENTIAL AND PROPRIETARY INFORMATION AND ALL DESIGN, MANUFACTURING, REPRODUCTION, USE, PATENT RIGHTS AND SALES RIGHTS ARE EXPRESSLY RESERVED BY SAMTEC, INC. THIS DOCUMENT SHALL NOT BE DISCLOSED, IN WHOLE OR PART, TO ANY UNAUTHORIZED PERSON OR ENTITY NOR REPRODUCED, TRANSFERRED OR INCORPORATED IN ANY OTHER PROJECT IN ANY MANNER WITHOUT THE EXPRESS WRITTEN CONSENT OF SAMTEC, INC.

DO NOT SCALE DRAWING

SHEET SCALE: 1:1



520 PARK EAST BLVD, NEW ALBANY, IN 47150
PHONE: 812-944-6733 FAX: 812-948-5047
e-Mail: info@SAMTEC.com code: 55322

DESCRIPTION:
SEALED CIRCULAR RECEPTACLE, ETHERNET
DWG. NO.

SCRES-X-XX.XX-XX-C5E

BY: CHADP 3/17/2009 SHEET 2 OF 6

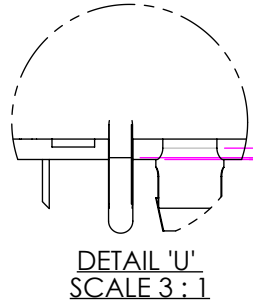

TRIM CLIPS TO FLUSH OR BELOW
0.00+0/.5

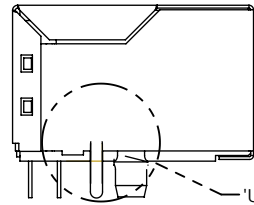
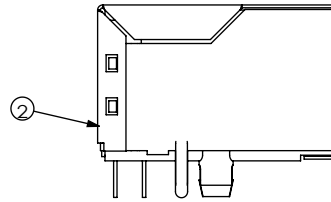

FIG 3

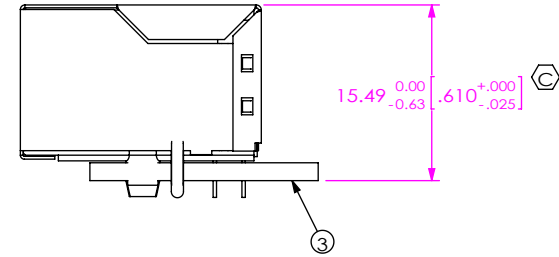
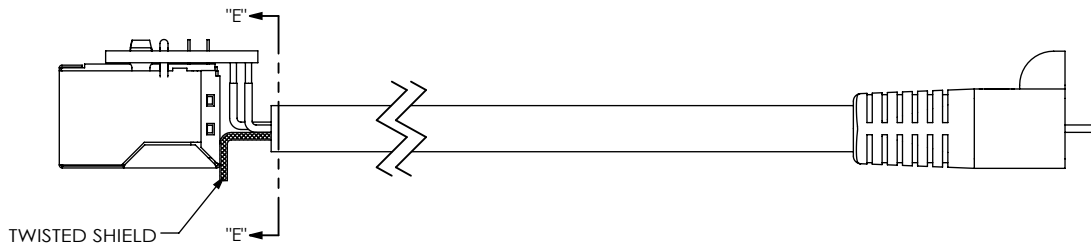
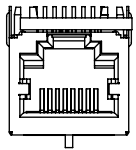
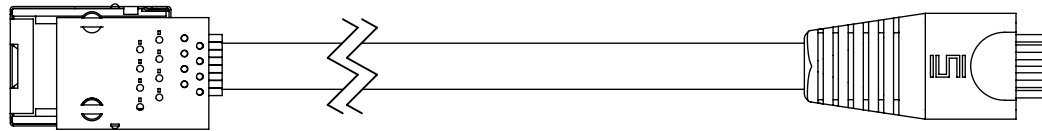

FIG 4
CONNECTOR SOLDERED TO PCB

-D: IN-PROCESS 4
SHEAR SHIELD TABS AND ALIGNMENT PINS
FLUSH WITH BOTTOM OF CONNECTOR
ADD SOLDER TO PCB



-D: IN-PROCESS 5
TERMINATE CABLE TO PCB, BRAID TO CONNECTOR SHIELD

TABLE 2 - PIN-OUT	
J1 POS	COLOR
01	WHITE/ORANGE
02	ORANGE
03	WHITE/GREEN
04	BLUE
05	WHITE/BLUE
06	GREEN
07	WHITE/BROWN
08	BROWN
SHELL	BRAID

3.59 [.141] MAX
(SHIELD TO BE SOLDERED IN
THIS AREA)

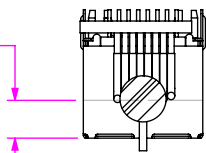

SECTION "E"-"E"

PROPRIETARY NOTE

THIS DOCUMENT CONTAINS CONFIDENTIAL AND PROPRIETARY INFORMATION AND ALL DESIGN, MANUFACTURING, REPRODUCTION, USE, PATENT RIGHTS AND SALES RIGHTS ARE EXPRESSLY RESERVED BY SAMTEC, INC. THIS DOCUMENT SHALL NOT BE DISCLOSED, IN WHOLE OR PART, TO ANY UNAUTHORIZED PERSON OR ENTITY NOR REPRODUCED, TRANSFERRED OR INCORPORATED IN ANY OTHER PROJECT IN ANY MANNER WITHOUT THE EXPRESS WRITTEN CONSENT OF SAMTEC, INC.

DO NOT SCALE DRAWING

SHEET SCALE: 1:1

samtec

520 PARK EAST BLVD, NEW ALBANY, IN 47150
PHONE: 812-944-6733 FAX: 812-948-5047
e-Mail: info@SAMTEC.com code: 55322

DESCRIPTION:
SEALED CIRCULAR RECEPTACLE, ETHERNET

DWG. NO.

SCRES-X-XX.XX-XX-C5E

BY: CHADP 3/17/2009 SHEET 3 OF 6

TABLE 3 - PIN-OUT		
J1 POS	COLOR	J2 POS
01	WHITE/ORANGE	01
02	ORANGE	02
03	WHITE/GREEN	03
04	BLUE	04
05	WHITE/BLUE	05
06	GREEN	06
07	WHITE/BROWN	07
08	BROWN	08
SHELL	BRAID	SHELL

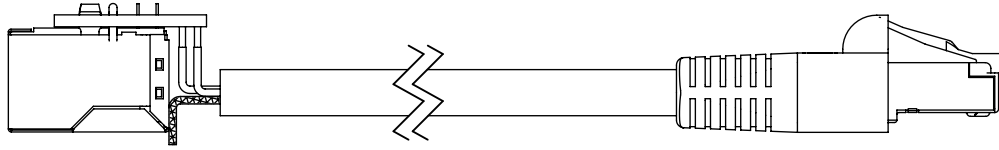

-D: IN-PROCESS 6
TERMINATE
(SEE NOTE 2)

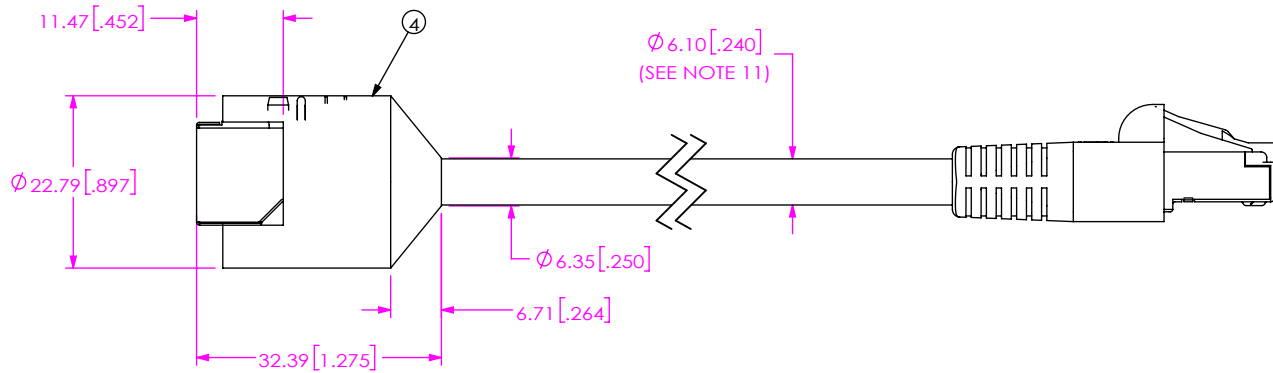

-D: IN-PROCESS 7
ADD PREMOLD

F:\DWG\MISC\MKTG\SCRES-X-XX-XX-XX-C5E-MKT.SLDDRW

PROPRIETARY NOTE
THIS DOCUMENT CONTAINS CONFIDENTIAL AND PROPRIETARY INFORMATION AND ALL DESIGN, MANUFACTURING, REPRODUCTION, USE, PATENT RIGHTS AND SALES RIGHTS ARE EXPRESSLY RESERVED BY SAMTEC, INC. THIS DOCUMENT SHALL NOT BE DISCLOSED, IN WHOLE OR PART, TO ANY UNAUTHORIZED PERSON OR ENTITY NOR REPRODUCED, TRANSFERRED OR INCORPORATED IN ANY OTHER PROJECT IN ANY MANNER WITHOUT THE EXPRESS WRITTEN CONSENT OF SAMTEC, INC.

DO NOT SCALE DRAWING

SHEET SCALE: 1:1



520 PARK EAST BLVD, NEW ALBANY, IN 47150
PHONE: 812-944-6733 FAX: 812-948-5047
e-Mail: info@SAMTEC.com code: 55322

DESCRIPTION:
SEALED CIRCULAR RECEPTACLE, ETHERNET
DWG. NO.

SCRES-X-XX-XX-XX-C5E

BY: CHADP 3/17/2009 SHEET 4 OF 6

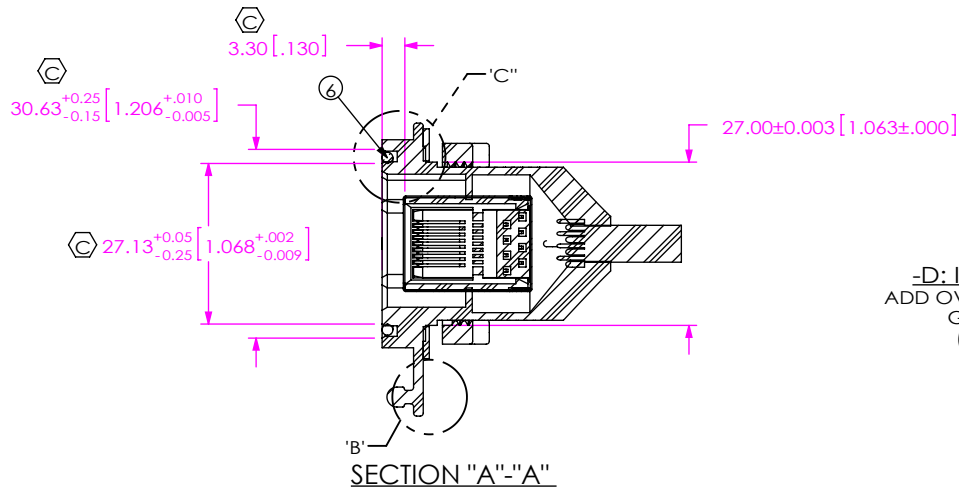
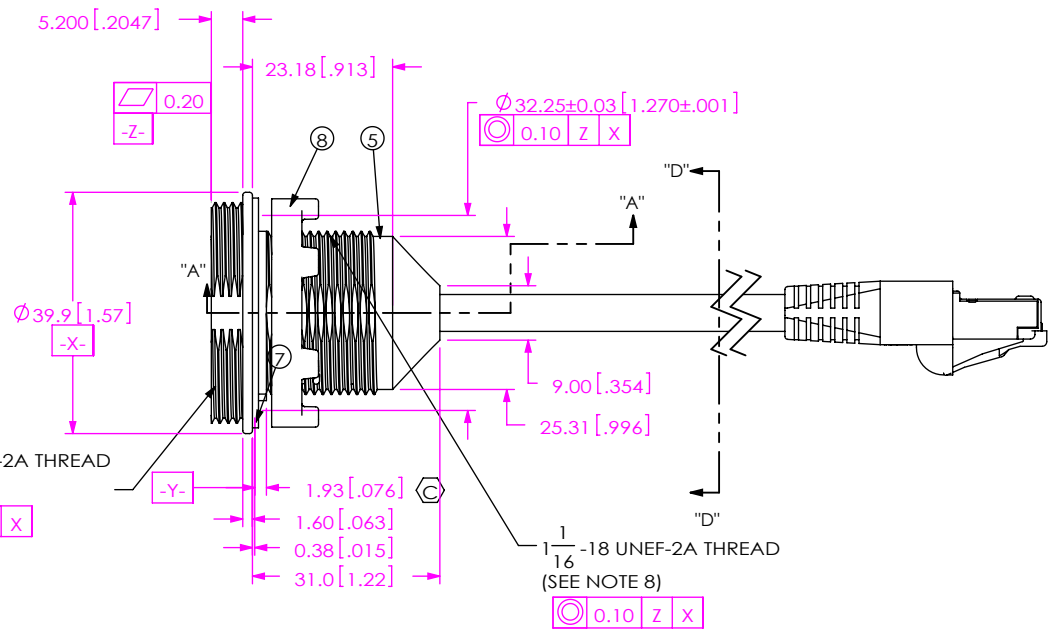
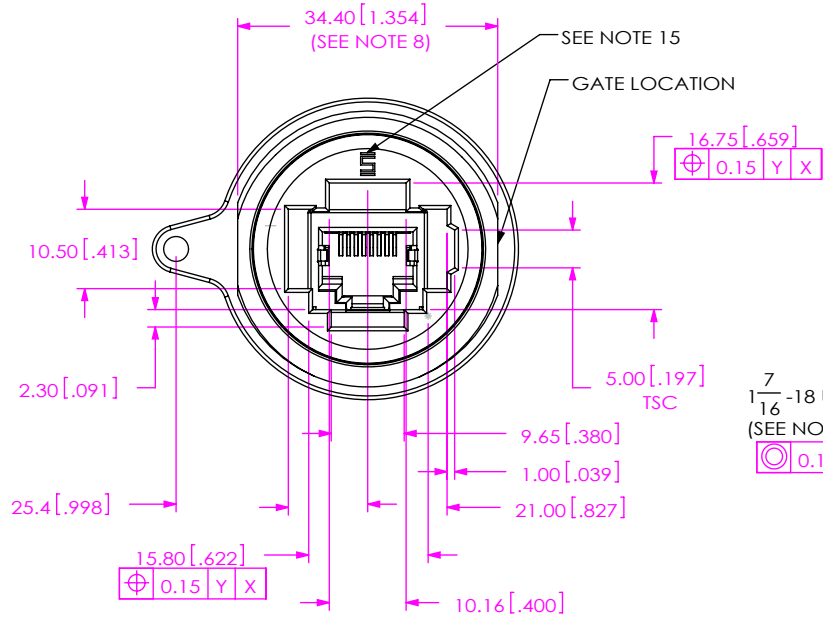

-D: IN-PROCESS 8
ADD OVER MOLD, O-RING,
GASKET & NUT
(SEE NOTE 2)

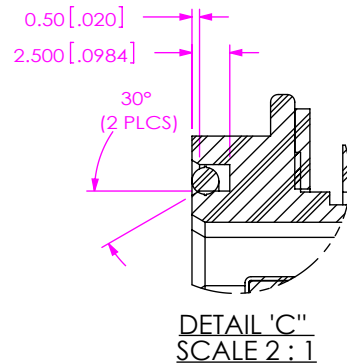
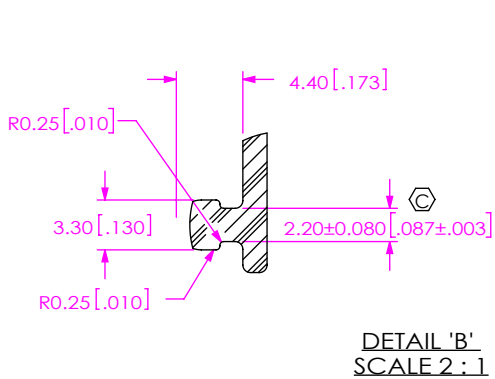
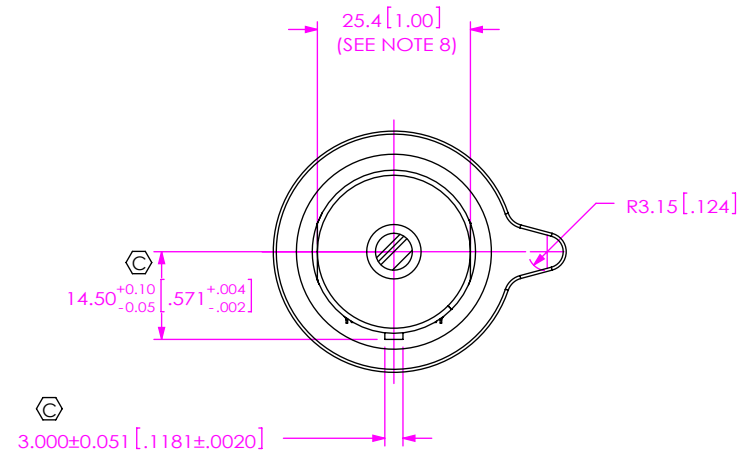

OR-17-01, SPG-17-01, & SPN-17-01
REMOVED FOR CLARITY

<p>PROPRIETARY NOTE</p> <p>THIS DOCUMENT CONTAINS CONFIDENTIAL AND PROPRIETARY INFORMATION AND ALL DESIGN, MANUFACTURING, REPRODUCTION, USE, PATENT RIGHTS AND SALES RIGHTS ARE EXPRESSLY RESERVED BY SAMTEC, INC. THIS DOCUMENT SHALL NOT BE DISCLOSED, IN WHOLE OR PART, TO ANY UNAUTHORIZED PERSON OR ENTITY NOR REPRODUCED, TRANSFERRED OR INCORPORATED IN ANY OTHER PROJECT IN ANY MANNER WITHOUT THE EXPRESS WRITTEN CONSENT OF SAMTEC, INC.</p> <p>DO NOT SCALE DRAWING</p> <p>SHEET SCALE: 1:1</p>		
	<p>520 PARK EAST BLVD, NEW ALBANY, IN 47150 PHONE: 812-944-6733 FAX: 812-948-5047 e-Mail: info@SAMTEC.com code: 55322</p>	
	<p>DESCRIPTION: SEALED CIRCULAR RECEPTACLE, ETHERNET</p>	
	<p>DWG. NO. SCRES-X-XX.XX-XX-C5E</p>	
<p>BY: CHADP</p>	<p>3/17/2009</p>	<p>SHEET 5 OF 6</p>

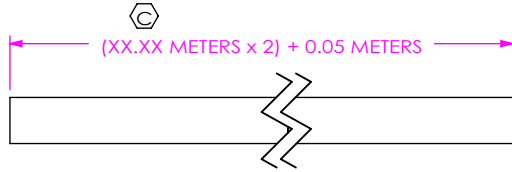

-BC: IN-PROCESS 1
CUT CABLES TO LENGTH

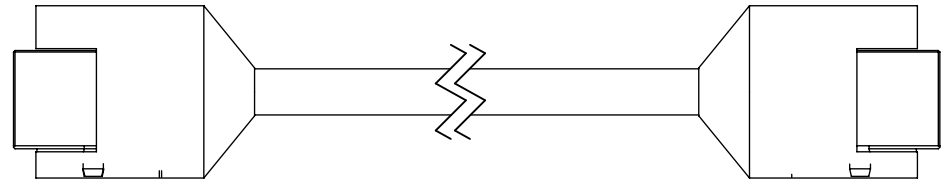

-BC: IN-PROCESS 5
(SAME AS -D IN-PROCESS 7 UNLESS OTHERWISE STATED)



-BC: IN-PROCESS 2
(SAME AS -D UNLESS OTHERWISE STATED)

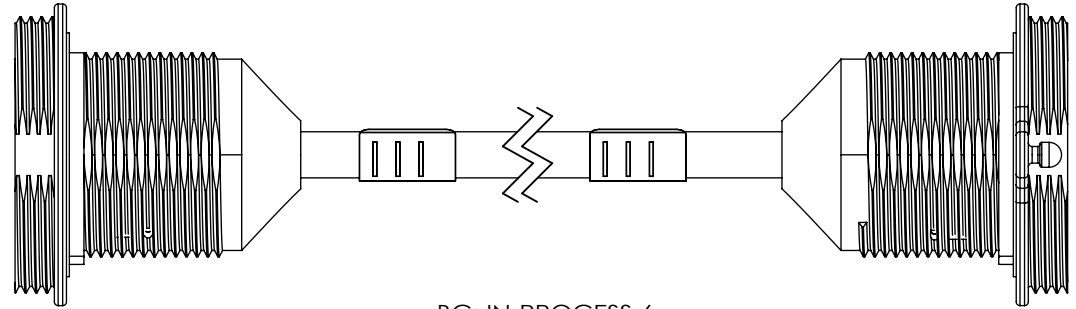

-BC: IN-PROCESS 6
(SAME AS -D IN-PROCESS 8 UNLESS OTHERWISE STATED)
(SEE NOTE 2)

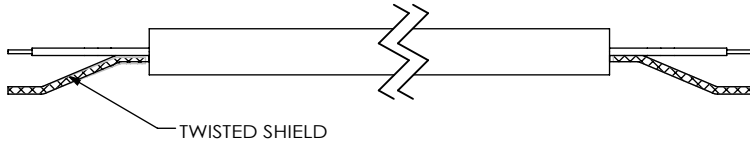

-BC: IN-PROCESS 3
(SAME AS -D UNLESS OTHERWISE STATED)

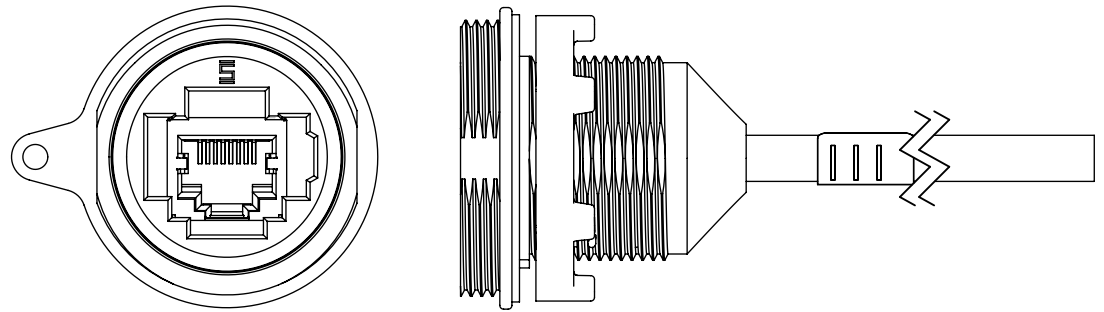

-BC: IN-PROCESS 7
CUT IN HALF & TRIM TO LENGTH
ADD O-RING, GASKET & NUT

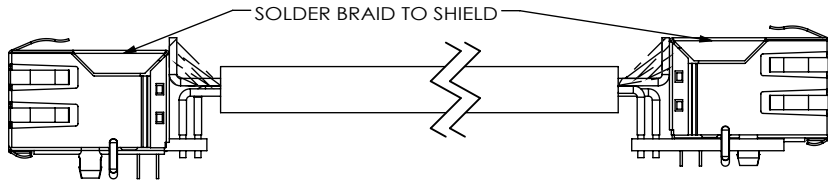

-BC: IN-PROCESS 4
(SAME AS -D UNLESS OTHERWISE STATED)

PROPRIETARY NOTE
THIS DOCUMENT CONTAINS CONFIDENTIAL AND PROPRIETARY INFORMATION AND ALL DESIGN, MANUFACTURING, REPRODUCTION, USE, PATENT RIGHTS AND SALES RIGHTS ARE EXPRESSLY RESERVED BY SAMTEC, INC. THIS DOCUMENT SHALL NOT BE DISCLOSED, IN WHOLE OR IN PART, TO ANY UNAUTHORIZED PERSON OR ENTITY NOR REPRODUCED, TRANSFERRED OR INCORPORATED IN ANY OTHER PROJECT IN ANY MANNER WITHOUT THE EXPRESS WRITTEN CONSENT OF SAMTEC, INC.

DO NOT SCALE DRAWING

SHEET SCALE: 1:1



520 PARK EAST BLVD, NEW ALBANY, IN 47150
PHONE: 812-944-6733 FAX: 812-948-5047
e-Mail: info@SAMTEC.com code: 55322

DESCRIPTION:
SEALED CIRCULAR RECEPTACLE, ETHERNET

DWG. NO.
SCRES-X-XX.XX-XX-C5E

BY: CHADP 3/17/2009 SHEET 6 OF 6