

# 74ALVT16827

20-bit buffer/line driver; non-inverting; 3-state

Rev. 03 — 2 June 2005

Product data sheet

## 1. General description

The 74ALVT16827 high-performance BiCMOS device combines low static and dynamic power dissipation with high speed and high output drive. It is designed for  $V_{CC}$  operation at 2.5 V or 3.3 V with I/O compatibility to 5 V.

The 74ALVT16827 20-bit buffers provide high performance bus interface buffering for wide data/address paths or buses carrying parity. They have NOR Output Enables ( $\overline{nOE1}$  and  $\overline{nOE2}$ ) for maximum control flexibility.

## 2. Features

- Multiple  $V_{CC}$  and GND pins minimize switching noise
- 5 V I/O compatible
- Live insertion and extraction permitted
- 3-state output buffers
- Power-up 3-state
- Output capability: +64 mA and -32 mA
- Latch-up protection:
  - ◆ JESD 78 exceeds 500 mA
- ElectroStatic Discharge (ESD) protection:
  - ◆ MIL STD 883 Method 3015: exceeds 2000 V
  - ◆ Machine model: exceeds 200 V
- Bus hold data inputs eliminate need for external pull-up resistors to hold unused inputs

## 3. Quick reference data

**Table 1: Quick reference data**

$GND = 0\text{ V}$ ;  $T_{amb} = 25\text{ }^{\circ}\text{C}$ .

Symbol	Parameter	Conditions	Min	Typ	Max	Unit
$t_{PLH}$	propagation delay nAx to nYx	$C_L = 50\text{ pF}$ ; $V_{CC} = 2.5\text{ V}$	1.0	2.0	2.9	ns
		$C_L = 50\text{ pF}$ ; $V_{CC} = 3.3\text{ V}$	0.7	1.5	2.2	ns
$t_{PHL}$	propagation delay nAx to nYx	$C_L = 50\text{ pF}$ ; $V_{CC} = 2.5\text{ V}$	1.0	2.0	3.0	ns
		$C_L = 50\text{ pF}$ ; $V_{CC} = 3.3\text{ V}$	0.8	1.6	2.3	ns
$C_I$	input capacitance on DIR, $\overline{OE}$	$V_I = 0\text{ V}$ or $V_{CC}$	-	3	-	pF

**PHILIPS**

**Table 1: Quick reference data ...continued**  
*GND = 0 V; T<sub>amb</sub> = 25 °C.*

Symbol	Parameter	Conditions	Min	Typ	Max	Unit
C <sub>O</sub>	output capacitance	V <sub>IO</sub> = 0 V or V <sub>CC</sub>	-	9	-	pF
I <sub>CC</sub>	total supply current	outputs disabled; V <sub>CC</sub> = 2.5 V	-	40	-	μA
		outputs disabled; V <sub>CC</sub> = 3.3 V	-	70	-	μA

### 4. Ordering information

**Table 2: Ordering information**

Type number	Package			Description	Version
	Temperature range	Name			
74ALVT16827DL	-40 °C to +85 °C	SSOP56		plastic shrink small outline package; 56 leads; body width 7.5 mm	SOT371-1
74ALVT16827DGG	-40 °C to +85 °C	TSSOP56		plastic thin shrink small outline package; 56 leads; body width 6.1 mm	SOT364-1

### 5. Functional diagram

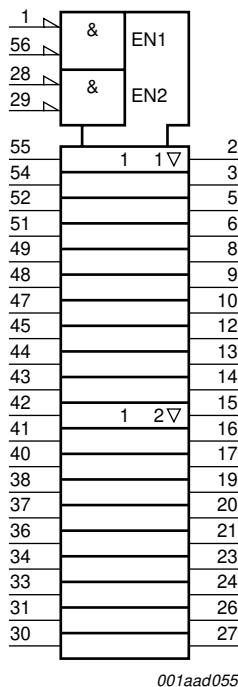

**Fig 1. Logic symbol**

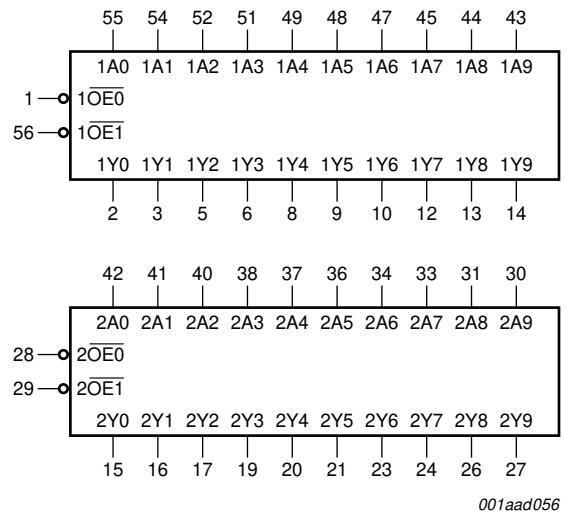

**Fig 2. IEC logic symbol**

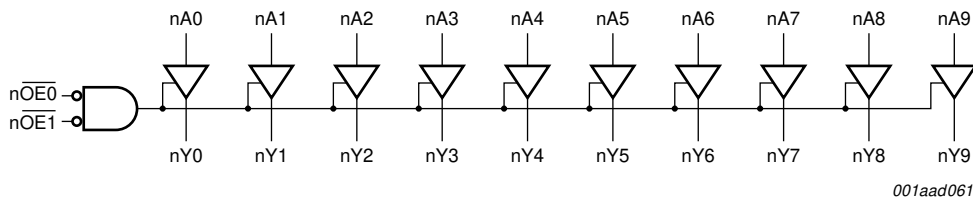

Fig 3. Logic diagram

## 6. Pinning information

### 6.1 Pinning

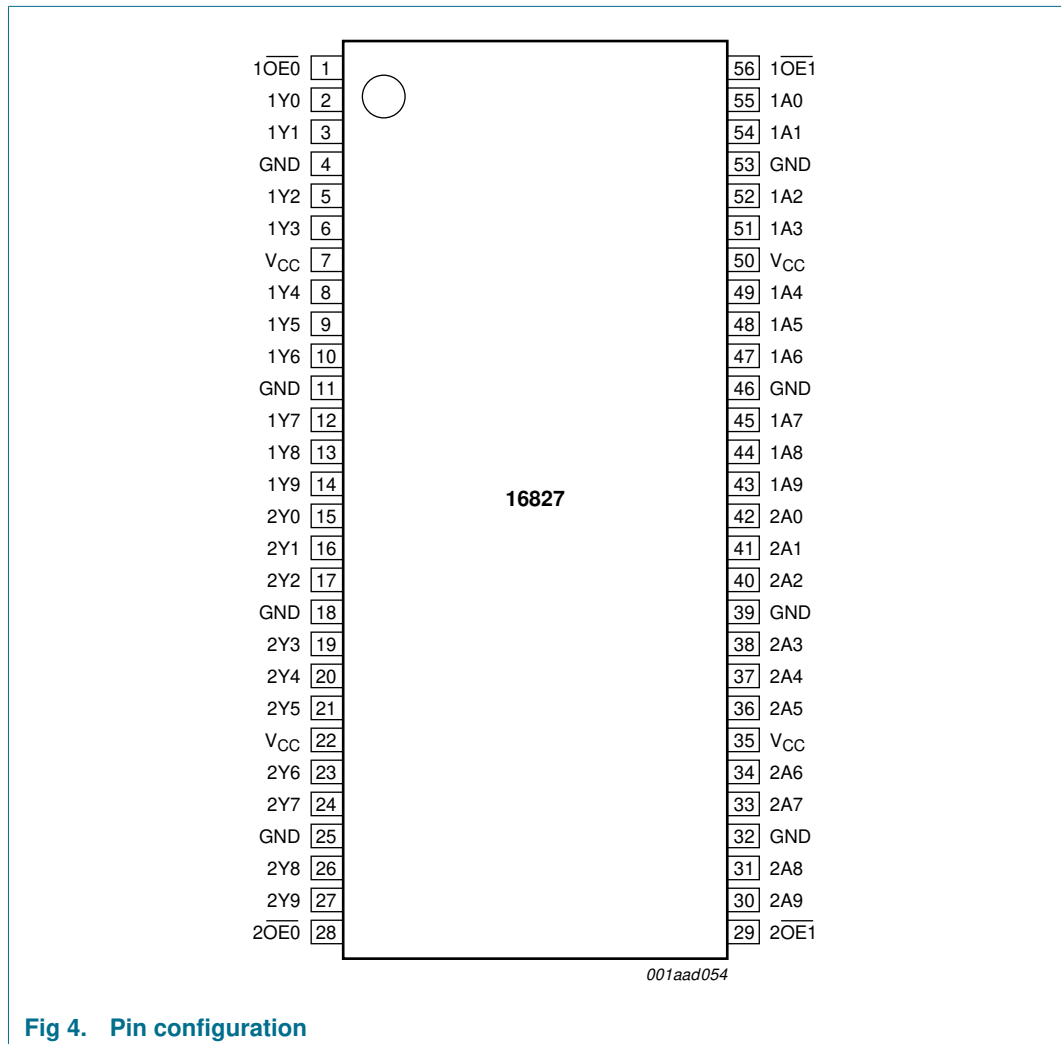

Fig 4. Pin configuration

## 6.2 Pin description

Table 3: Pin description

Symbol	Pin	Description
$1\overline{OE}0$	1	output enable input (active-LOW)
1Y0	2	data output
1Y1	3	data output
GND	4	ground (0 V)
1Y2	5	data output
1Y3	6	data output
V <sub>CC</sub>	7	positive voltage supply
1Y4	8	data output
1Y5	9	data output
1Y6	10	data output
GND	11	ground (0 V)
1Y7	12	data output
1Y8	13	data output
1Y9	14	data output
2Y0	15	data output
2Y1	16	data output
2Y2	17	data output
GND	18	ground (0 V)
2Y3	19	data output
2Y4	20	data output
2Y5	21	data output
V <sub>CC</sub>	22	positive voltage supply
2Y6	23	data output
2Y7	24	data output
GND	25	ground (0 V)
2Y8	26	data output
2Y9	27	data output
$2\overline{OE}0$	28	output enable input (active-LOW)
$2\overline{OE}1$	29	output enable input (active-LOW)
2A9	30	data input
2A8	31	data input
GND	32	ground (0 V)
2A7	33	data input
2A6	34	data input
V <sub>CC</sub>	35	positive voltage supply
2A5	36	data input
2A4	37	data input
2A3	38	data input
GND	39	ground (0 V)

Table 3: Pin description ...continued

Symbol	Pin	Description
2A2	40	data input
2A1	41	data input
2A0	42	data input
1A9	43	data input
1A8	44	data input
1A7	45	data input
GND	46	ground (0 V)
1A6	47	data input
1A5	48	data input
1A4	49	data input
V <sub>CC</sub>	50	positive voltage supply
1A3	51	data input
1A2	52	data input
GND	53	ground (0 V)
1A1	54	data input
1A0	55	data input
1 $\overline{\text{OE}}$ 1	56	output enable input (active-LOW)

## 7. Functional description

### 7.1 Function table

Table 4: Function table [1]

Input		Output	Operating mode
nOEx	nAx	nYx	
L	L	L	transparent
L	H	H	transparent
H	X	Z	High-impedance

- [1] X = don't care;  
 Z = High-impedance OFF-state;  
 H = HIGH voltage level;  
 L = LOW voltage level.

## 8. Limiting values

Table 5: Limiting values

In accordance with the Absolute Maximum Rating System (IEC 60134). [2] Voltages are referenced to GND (ground = 0 V).

Symbol	Parameter	Conditions	Min	Max	Unit
V <sub>CC</sub>	supply voltage		-0.5	+7.0	V
I <sub>IK</sub>	input diode current	V <sub>I</sub> < 0 V	-18	-	mA
V <sub>I</sub>	input voltage		[2] -1.2	+7.0	V
I <sub>OK</sub>	output diode current	V <sub>O</sub> < 0 V	-50	-	mA

**Table 5: Limiting values ...continued**

In accordance with the Absolute Maximum Rating System (IEC 60134). [1] Voltages are referenced to GND (ground = 0 V).

Symbol	Parameter	Conditions	Min	Max	Unit
V <sub>O</sub>	output voltage	output in OFF or HIGH-state	[2] -0.5	+5.5	V
I <sub>O</sub>	output current	output in LOW-state	-	128	mA
T <sub>j</sub>	junction temperature		-	150	°C
T <sub>stg</sub>	storage temperature		-65	+150	°C

[1] The performance capability of a high-performance integrated circuit in conjunction with its thermal environment can create junction temperatures which are detrimental to reliability. Exceed 150 °C.

[2] The input and output voltage ratings may be exceeded if the input and output current ratings are observed.

## 9. Recommended operating conditions

**Table 6: Recommended operating conditions**

Symbol	Parameter	Conditions	Min	Typ	Max	Unit
<b>V<sub>CC</sub> = 3.3 V ± 0.3 V</b>						
V <sub>CC</sub>	supply voltage		3.0	-	3.6	V
V <sub>I</sub>	input voltage		0	-	5.5	V
V <sub>IH</sub>	HIGH-level input voltage		2.0	-	-	V
V <sub>IL</sub>	input voltage		-	-	0.8	V
I <sub>OH</sub>	HIGH-level output current		-	-	-32	mA
I <sub>OL</sub>	LOW-level output current		-	-	32	mA
		current duty cycle ≤ 50 %; f ≥ 1 kHz	-	-	64	mA
Δt/Δv	input transition rise or fall rate	outputs enabled	-	-	10	ns/V
T <sub>amb</sub>	ambient temperature		-40	-	+85	°C
<b>V<sub>CC</sub> = 2.5 V ± 0.2 V</b>						
V <sub>CC</sub>	supply voltage		2.3	-	2.7	V
V <sub>I</sub>	input voltage		0	-	5.5	V
V <sub>IH</sub>	HIGH-level input voltage		1.7	-	-	V
V <sub>IL</sub>	input voltage		-	-	0.7	V
I <sub>OH</sub>	HIGH-level output current		-	-	-8	mA
I <sub>OL</sub>	LOW-level output current		-	-	8	mA
		current duty cycle ≤ 50 %; f ≥ 1 kHz	-	-	24	mA
Δt/Δv	input transition rise or fall rate	outputs enabled	-	-	10	ns/V
T <sub>amb</sub>	ambient temperature		-40	-	+85	°C

## 10. Static characteristics

**Table 7: Static characteristics**

At recommended operating conditions; voltages are referred to GND (ground = 0 V).  $T_{amb} = -40\text{ }^{\circ}\text{C}$  to  $+85\text{ }^{\circ}\text{C}$ .

Symbol	Parameter	Conditions	Min	Typ	Max	Unit	
<b><math>V_{CC} = 3.3\text{ V} \pm 0.3\text{ V}</math> [1]</b>							
$V_{IK}$	input clamp voltage	$V_{CC} = 3.0\text{ V}$ ; $I_{IK} = -18\text{ mA}$	-	-0.85	-1.2	V	
$V_{OH}$	HIGH-level output voltage	$V_{CC} = 3.0\text{ V}$ to $3.6\text{ V}$ ; $I_{OH} = -100\text{ }\mu\text{A}$	$V_{CC} - 0.2$	$V_{CC}$	-	V	
		$V_{CC} = 3.0\text{ V}$ ; $I_{OH} = -32\text{ mA}$	2.0	2.3	-	V	
$V_{OL}$	LOW-level output voltage	$V_{CC} = 3.0\text{ V}$					
		$I_{OL} = 100\text{ }\mu\text{A}$	[2] -	0.07	0.2	V	
		$I_{OL} = 16\text{ mA}$	[2] -	0.25	0.4	V	
		$I_{OL} = 32\text{ mA}$	[2] -	0.3	0.5	V	
$I_{LI}$	input leakage current	control pins	$V_{CC} = 3.6\text{ V}$ ; $V_I = V_{CC}$ or GND	-	0.1	$\pm 1$	$\mu\text{A}$
			$V_{CC} = 0\text{ V}$ or $3.6\text{ V}$ ; $V_I = 5.5\text{ V}$	-	0.1	10	$\mu\text{A}$
		I/O data pins	$V_{CC} = 3.6\text{ V}$ ; $V_I = V_{CC}$	[2] -	0.5	1	$\mu\text{A}$
			$V_{CC} = 3.6\text{ V}$ ; $V_I = 0\text{ V}$	[2] -	+0.1	-5	$\mu\text{A}$
$I_{OFF}$	off current	$V_{CC} = 0\text{ V}$ ; $V_I$ or $V_O = 0\text{ V}$ to $4.5\text{ V}$	-	0.1	$\pm 100$	$\mu\text{A}$	
$I_{HOLD}$	bus hold current data inputs	$V_{CC} = 3\text{ V}$ ; $V_I = 0.8\text{ V}$	[3] 75	130	-	$\mu\text{A}$	
		$V_{CC} = 3\text{ V}$ ; $V_I = 2.0\text{ V}$	[3] -75	-140	-	$\mu\text{A}$	
		$V_{CC} = 0\text{ V}$ to $3.6\text{ V}$ ; $V_{CC} = 3.6\text{ V}$	[3] $\pm 500$	-	-	$\mu\text{A}$	
$I_{EX}$	current into an output in the HIGH-state when $V_O > V_{CC}$	$V_O = 5.5\text{ V}$ ; $V_{CC} = 3.0\text{ V}$	-	10	125	$\mu\text{A}$	
$I_{PU}, I_{PD}$	power-up/down 3-state output current	$V_{CC} \leq 1.2\text{ V}$ ; $V_O = 0.5\text{ V}$ to $V_{CC}$ ; $V_I = \text{GND}$ or $V_{CC}$ ; $n\overline{OEX} = \text{don't care}$	[4] -	1	$\pm 100$	$\mu\text{A}$	
$I_{OZ}$	3-state output current	$V_{CC} = 3.6\text{ V}$ ; $V_I = V_{IL}$ or $V_{IH}$					
		output HIGH; $V_O = 3.0\text{ V}$	-	0.5	5	$\mu\text{A}$	
		output LOW; $V_O = 0.5\text{ V}$	-	+0.5	-5	$\mu\text{A}$	
$I_{CC}$	quiescent supply current	$V_{CC} = 3.6\text{ V}$ ; $V_I = \text{GND}$ or $V_{CC}$ ; $I_O = 0\text{ A}$					
		outputs HIGH	-	0.07	0.1	$\text{mA}$	
		outputs LOW	-	4.2	6	$\text{mA}$	
$\Delta I_{CC}$	additional supply current per input pin	$V_{CC} = 3\text{ V}$ to $3.6\text{ V}$ ; one input at $V_{CC} - 0.6\text{ V}$ , other inputs at $V_{CC}$ or GND	[6] -	0.04	0.4	$\text{mA}$	
$C_I$	input capacitance	$V_I = 0\text{ V}$ or $V_{CC}$	-	3	-	$\text{pF}$	
$C_O$	output capacitance	$V_{IO} = 0\text{ V}$ or $V_{CC}$	-	9	-	$\text{pF}$	

**Table 7: Static characteristics ...continued**At recommended operating conditions; voltages are referred to GND (ground = 0 V).  $T_{amb} = -40\text{ }^{\circ}\text{C}$  to  $+85\text{ }^{\circ}\text{C}$ .

Symbol	Parameter	Conditions	Min	Typ	Max	Unit	
<b><math>V_{CC} = 2.5\text{ V} \pm 0.2\text{ V}</math> [7]</b>							
$V_{IK}$	input clamp voltage	$V_{CC} = 2.3\text{ V}$ ; $I_{IK} = -18\text{ mA}$	-	-0.85	-1.2	V	
$V_{OH}$	HIGH-level output voltage	$V_{CC} = 2.3\text{ V}$ to $2.7\text{ V}$ ; $I_{OH} = -100\text{ }\mu\text{A}$	$V_{CC} - 0.2$	$V_{CC}$	-	V	
		$V_{CC} = 2.3\text{ V}$ ; $I_{OH} = -8\text{ mA}$	1.8	2.1	-	V	
$V_{OL}$	LOW-level output voltage	$V_{CC} = 2.3\text{ V}$					
		$I_{OL} = 100\text{ }\mu\text{A}$	-	0.07	0.2	V	
		$I_{OL} = 24\text{ mA}$	-	0.3	0.5	V	
		$I_{OL} = 100\text{ }\mu\text{A}$	-	0.07	0.2	V	
$I_{LI}$	input leakage current	$V_{CC} = 2.3\text{ V}$ ; $I_{OL} = 24\text{ mA}$	-	0.3	0.5	V	
	control pins	$V_{CC} = 2.7\text{ V}$ ; $V_I = V_{CC}$ or GND	-	0.1	$\pm 1$	$\mu\text{A}$	
	I/O data pins	$V_{CC} = 0\text{ V}$ or $2.7\text{ V}$ ; $V_I = 5.5\text{ V}$	[2]	-	0.1	10	$\mu\text{A}$
		$V_{CC} = 2.7\text{ V}$ ; $V_I = V_{CC}$	[2]	-	0.1	1	$\mu\text{A}$
		$V_{CC} = 2.7\text{ V}$ ; $V_I = 0\text{ V}$	[2]	-	+0.1	-5	$\mu\text{A}$
$I_{OFF}$	off current	$V_{CC} = 0\text{ V}$ ; $V_I$ or $V_O = 0\text{ V}$ to $4.5\text{ V}$	-	0.1	$\pm 100$	$\mu\text{A}$	
$I_{HOLD}$	bus hold current data inputs	$V_{CC} = 2.5\text{ V}$ ; $V_I = 0.8\text{ V}$	[3]	-	115	-	$\mu\text{A}$
		$V_{CC} = 2.5\text{ V}$ ; $V_I = 2.0\text{ V}$	[3]	-	-10	-	$\mu\text{A}$
$I_{EX}$	current into an output in the HIGH-state when $V_O > V_{CC}$	$V_O = 5.5\text{ V}$ ; $V_{CC} = 2.3\text{ V}$	-	10	125	$\mu\text{A}$	
$I_{PU}$ , $I_{PD}$	power-up/down 3-state output current	$V_{CC} \leq 1.2\text{ V}$ ; $V_O = 0.5\text{ V}$ to $V_{CC}$ ; $V_I = \text{GND}$ or $V_{CC}$ ; nOEx = don't care	[4]	-	1	100	$\mu\text{A}$
$I_{OZ}$	3-state output current	$V_{CC} = 2.7\text{ V}$ ; $V_O = 2.3\text{ V}$ ; $V_I = V_{IL}$ or $V_{IH}$					
		output HIGH; $V_O = 2.3\text{ V}$	-	0.5	5	$\mu\text{A}$	
		output LOW; $V_O = 0.5\text{ V}$	-	+0.5	-5	$\mu\text{A}$	
$I_{CC}$	quiescent supply current	$V_{CC} = 2.7\text{ V}$ ; $V_I = \text{GND}$ or $V_{CC}$ ; $I_O = 0\text{ A}$					
		outputs HIGH	-	0.04	0.1	mA	
		outputs LOW	-	3.6	5.0	mA	
		outputs disabled	[5]	-	0.04	0.1	mA
$\Delta I_{CC}$	additional supply current per input pin	$V_{CC} = 2.3\text{ V}$ to $2.7\text{ V}$ ; one input at $V_{CC} - 0.6\text{ V}$ , other inputs at $V_{CC}$ or GND	[6]	-	0.04	0.4	mA

[1] All typical values are at  $V_{CC} = 3.3\text{ V}$  and  $T_{amb} = 25\text{ }^{\circ}\text{C}$ .[2] Unused pins at  $V_{CC}$  or GND.

[3] This is the bus hold overdrive current required to force the input to the opposite logic state.

[4] This parameter is valid for any  $V_{CC}$  between 0 V and 1.2 V with a transition time of up to 10 ms. From  $V_{CC} = 1.2\text{ V}$  to  $V_{CC} = 3.3\text{ V} \pm 0.3\text{ V}$  a transition time of 100  $\mu\text{s}$  is permitted. This parameter is valid for  $T_{amb} = 25\text{ }^{\circ}\text{C}$  only.[5]  $I_{CC}$  is measured with outputs pulled up to  $V_{CC}$  or pulled down to ground.[6] This is the increase in supply current for each input at the specified voltage level other than  $V_{CC}$  or GND.[7] All typical values are at  $V_{CC} = 2.5\text{ V}$  and  $T_{amb} = 25\text{ }^{\circ}\text{C}$ .



## 11. Dynamic characteristics

**Table 8: Dynamic characteristics**

$GND = 0\text{ V}$ ;  $t_r = t_f = 2.5\text{ ns}$ ;  $C_L = 50\text{ pF}$ ;  $R_L = 500\ \Omega$ ;  $T_{amb} = -40\text{ }^\circ\text{C to } +85\text{ }^\circ\text{C}$ ; for test circuit see [Figure 7](#).

Symbol	Parameter	Conditions	Min	Typ	Max	Unit
<b><math>V_{CC} = 3.3\text{ V} \pm 0.3\text{ V}</math></b>						
$t_{PLH}$	propagation delay nAx to nYx	see <a href="#">Figure 5</a>	0.7	1.5	2.2	ns
$t_{PHL}$	propagation delay nAx to nYx	see <a href="#">Figure 5</a>	0.8	1.6	2.3	ns
$t_{PZH}$	output enable time to HIGH-level	see <a href="#">Figure 6</a>	1.6	2.6	3.8	ns
$t_{PZL}$	output enable time to LOW-level	see <a href="#">Figure 6</a>	1.4	2.3	3.2	ns
$t_{PHZ}$	output disable time from HIGH-level	see <a href="#">Figure 6</a>	2.3	3.2	4.8	ns
$t_{PLZ}$	output disable time from LOW-level	see <a href="#">Figure 6</a>	1.5	2.5	3.8	ns
<b><math>V_{CC} = 2.5\text{ V} \pm 0.2\text{ V}</math></b>						
$t_{PLH}$	propagation delay nAx to nYx	see <a href="#">Figure 5</a>	1.0	2.0	2.9	ns
$t_{PHL}$	propagation delay nAx to nYx	see <a href="#">Figure 5</a>	1.0	2.0	3.0	ns
$t_{PZH}$	output enable time to HIGH-level	see <a href="#">Figure 6</a>	2.0	3.2	5.5	ns
$t_{PZL}$	output enable time to LOW-level	see <a href="#">Figure 6</a>	1.7	2.9	4.3	ns
$t_{PHZ}$	output disable time from HIGH-level	see <a href="#">Figure 6</a>	1.8	2.8	5.1	ns
$t_{PLZ}$	output disable time from LOW-level	see <a href="#">Figure 6</a>	1.4	2.3	3.9	ns

12. AC waveforms

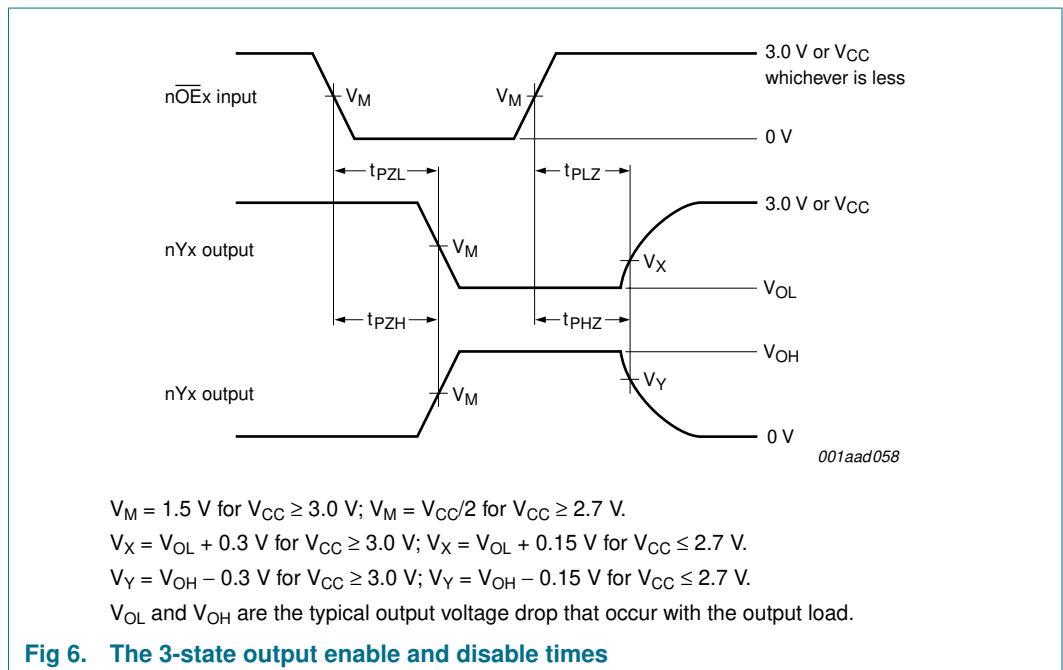
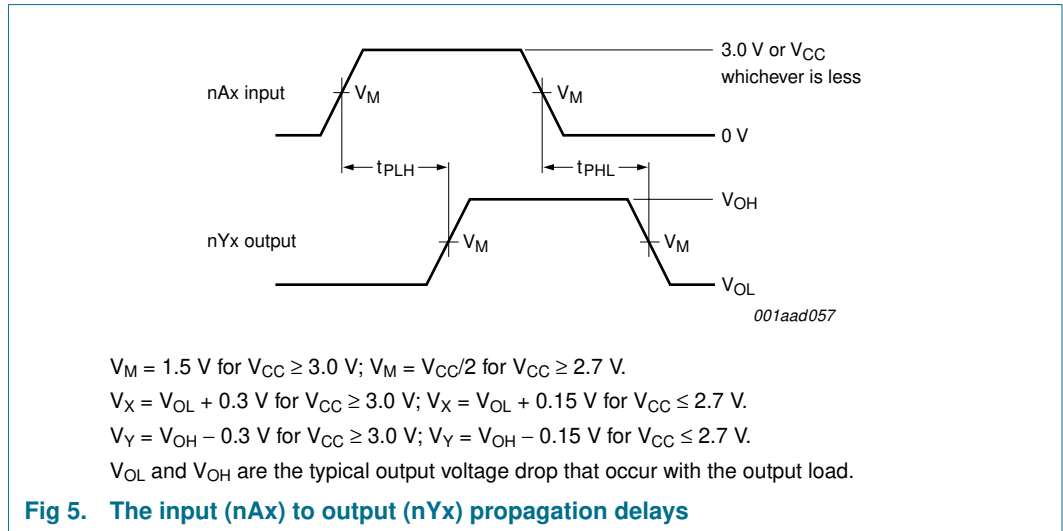

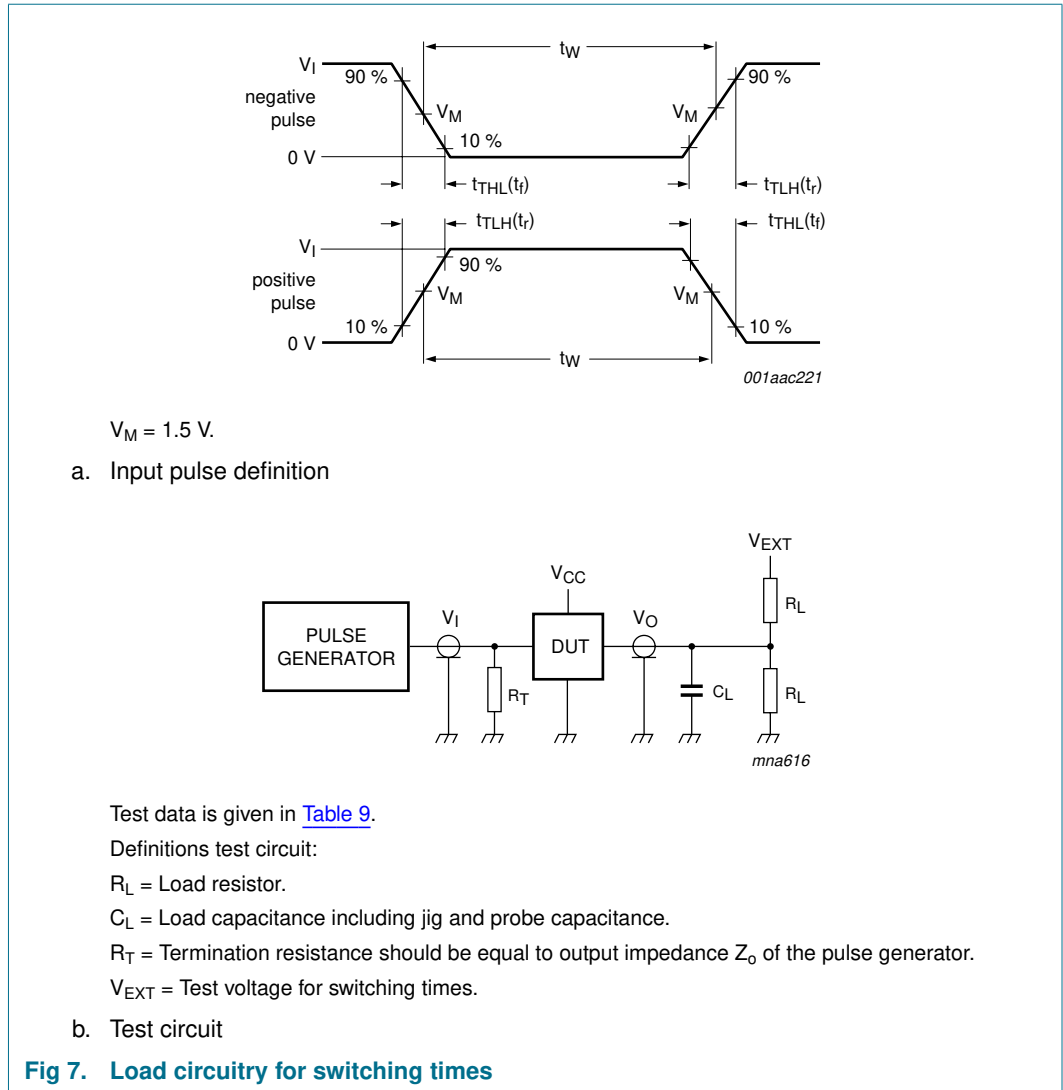

**Table 9: Test data**

Input				Load		$V_{EXT}$		
$V_I$	$f_i$	$t_w$	$t_r, t_f$	$C_L$	$R_L$	$t_{PLH}, t_{PHL}$	$t_{PZH}, t_{PHZ}$	$t_{PZL}, t_{PLZ}$
3.0 V or $V_{CC}$ whichever is less	$\leq 10 \text{ MHz}$	500 ns	$\leq 2.5 \text{ ns}$	50 pF	500 $\Omega$	6 V or $V_{CC} \times 2$	open	GND

13. Package outline

SSOP56: plastic shrink small outline package; 56 leads; body width 7.5 mm

SOT371-1

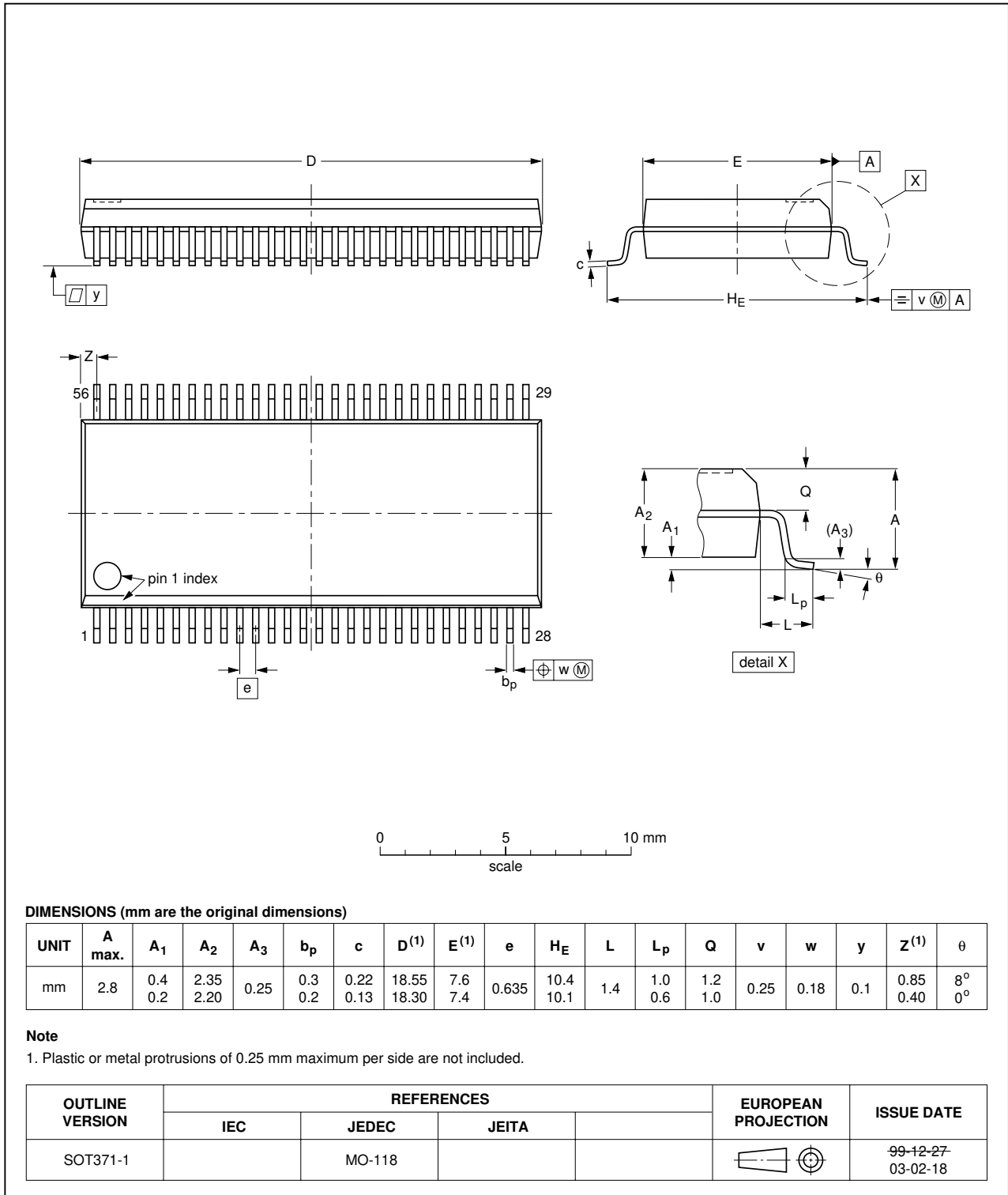

Fig 8. Package outline SOT371-1 (SSOP56)

TSSOP56: plastic thin shrink small outline package; 56 leads; body width 6.1 mm

SOT364-1

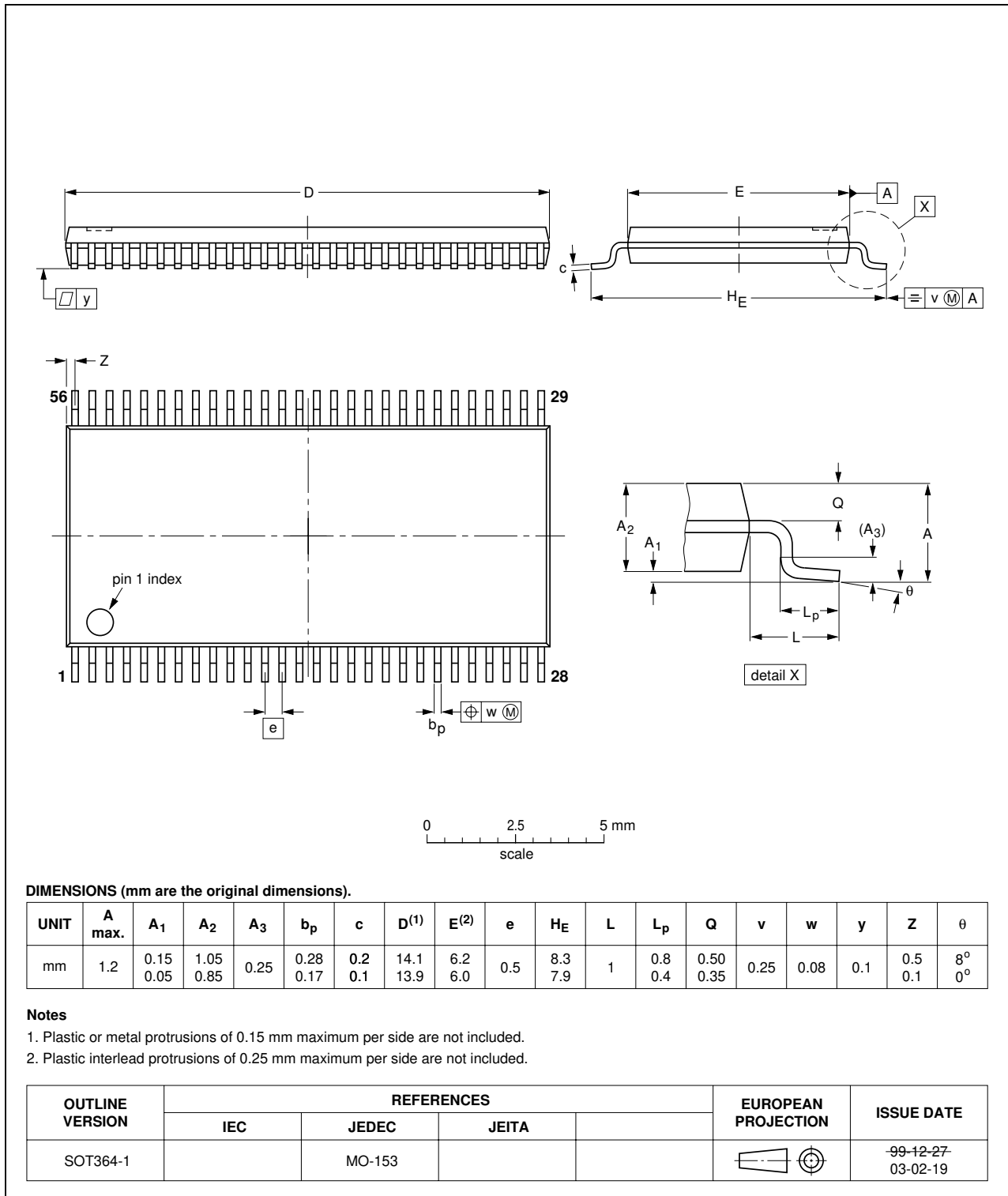

Fig 9. Package outline SOT364-1 (TSSOP56)

## 14. Revision history

Table 10: Revision history

Document ID	Release date	Data sheet status	Change notice	Doc. number	Supersedes
74ALVT16827_3	20050602	Product data sheet	-	9397 750 15122	74ALVT16827_2
Modifications:					
					<ul style="list-style-type: none"><li>The format of this data sheet has been redesigned to comply with the new presentation and information standard of Philips Semiconductors.</li><li><a href="#">Section 2 “Features”</a>: modified ‘JEDEC Std 17’ into ‘JESD78’.</li><li><a href="#">Section 11 “Dynamic characteristics”</a>: changed values in column ‘min’</li></ul>

## 15. Data sheet status

Level	Data sheet status <sup>[1]</sup>	Product status <sup>[2]</sup> <sup>[3]</sup>	Definition
I	Objective data	Development	This data sheet contains data from the objective specification for product development. Philips Semiconductors reserves the right to change the specification in any manner without notice.
II	Preliminary data	Qualification	This data sheet contains data from the preliminary specification. Supplementary data will be published at a later date. Philips Semiconductors reserves the right to change the specification without notice, in order to improve the design and supply the best possible product.
III	Product data	Production	This data sheet contains data from the product specification. Philips Semiconductors reserves the right to make changes at any time in order to improve the design, manufacturing and supply. Relevant changes will be communicated via a Customer Product/Process Change Notification (CPCN).

[1] Please consult the most recently issued data sheet before initiating or completing a design.

[2] The product status of the device(s) described in this data sheet may have changed since this data sheet was published. The latest information is available on the Internet at URL <http://www.semiconductors.philips.com>.

[3] For data sheets describing multiple type numbers, the highest-level product status determines the data sheet status.

## 16. Definitions

**Short-form specification** — The data in a short-form specification is extracted from a full data sheet with the same type number and title. For detailed information see the relevant data sheet or data handbook.

**Limiting values definition** — Limiting values given are in accordance with the Absolute Maximum Rating System (IEC 60134). Stress above one or more of the limiting values may cause permanent damage to the device. These are stress ratings only and operation of the device at these or at any other conditions above those given in the Characteristics sections of the specification is not implied. Exposure to limiting values for extended periods may affect device reliability.

**Application information** — Applications that are described herein for any of these products are for illustrative purposes only. Philips Semiconductors make no representation or warranty that such applications will be suitable for the specified use without further testing or modification.

## 17. Disclaimers

**Life support** — These products are not designed for use in life support appliances, devices, or systems where malfunction of these products can reasonably be expected to result in personal injury. Philips Semiconductors

## 19. Contact information

For additional information, please visit: <http://www.semiconductors.philips.com>

For sales office addresses, send an email to: [sales.addresses@www.semiconductors.philips.com](mailto:sales.addresses@www.semiconductors.philips.com)

customers using or selling these products for use in such applications do so at their own risk and agree to fully indemnify Philips Semiconductors for any damages resulting from such application.

**Right to make changes** — Philips Semiconductors reserves the right to make changes in the products - including circuits, standard cells, and/or software - described or contained herein in order to improve design and/or performance. When the product is in full production (status 'Production'), relevant changes will be communicated via a Customer Product/Process Change Notification (CPCN). Philips Semiconductors assumes no responsibility or liability for the use of any of these products, conveys no license or title under any patent, copyright, or mask work right to these products, and makes no representations or warranties that these products are free from patent, copyright, or mask work right infringement, unless otherwise specified.

## 18. Trademarks

**Notice** — All referenced brands, product names, service names and trademarks are the property of their respective owners.

## 20. Contents

1	General description . . . . .	1
2	Features . . . . .	1
3	Quick reference data . . . . .	1
4	Ordering information . . . . .	2
5	Functional diagram . . . . .	2
6	Pinning information . . . . .	3
6.1	Pinning . . . . .	3
6.2	Pin description . . . . .	4
7	Functional description . . . . .	5
7.1	Function table . . . . .	5
8	Limiting values . . . . .	5
9	Recommended operating conditions . . . . .	6
10	Static characteristics . . . . .	7
11	Dynamic characteristics . . . . .	9
12	AC waveforms . . . . .	10
13	Package outline . . . . .	12
14	Revision history . . . . .	14
15	Data sheet status . . . . .	15
16	Definitions . . . . .	15
17	Disclaimers . . . . .	15
18	Trademarks . . . . .	15
19	Contact information . . . . .	15



© Koninklijke Philips Electronics N.V. 2005

All rights are reserved. Reproduction in whole or in part is prohibited without the prior written consent of the copyright owner. The information presented in this document does not form part of any quotation or contract, is believed to be accurate and reliable and may be changed without notice. No liability will be accepted by the publisher for any consequence of its use. Publication thereof does not convey nor imply any license under patent- or other industrial or intellectual property rights.

Date of release: 2 June 2005  
Document number: 9397 750 15122

Published in The Netherlands