

THIS DRAWING IS UNPUBLISHED. RELEASED FOR PUBLICATION
 © COPYRIGHT - By - ALL RIGHTS RESERVED.

LOC	DIST	REVISIONS			
P	LTR	DESCRIPTION	DATE	DWN	APVD
AF	50	B4	REVISED PER ECR-19-017984	27NOV2019	PC MK

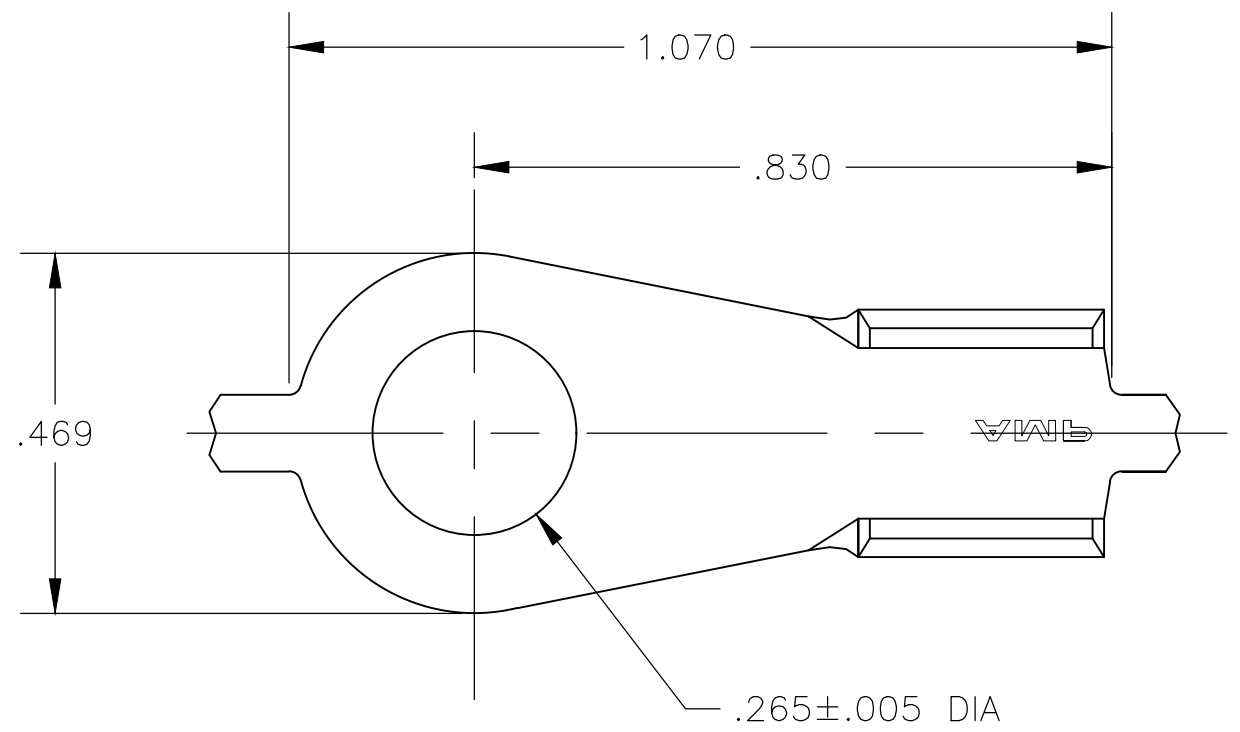

- 1 CONTINUOUS STRIP ON REELS.
- △2 TIN PLATING
- △3 PRELIMINARY - NOT FOR PRODUCTION
- △4 SPLICE FREE REELS.
- 5 WIRE SIZE #10-#6

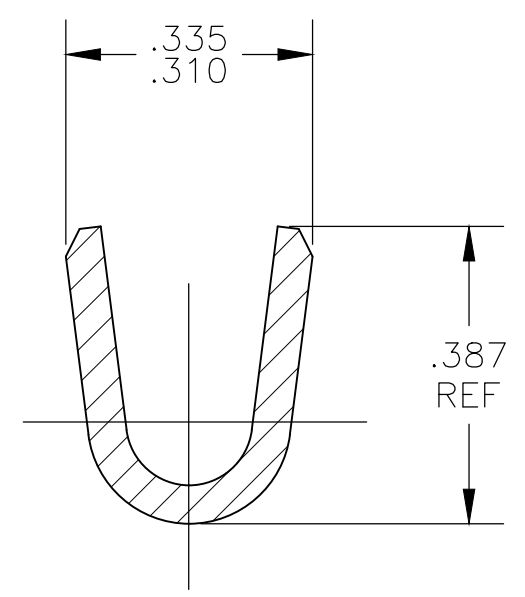
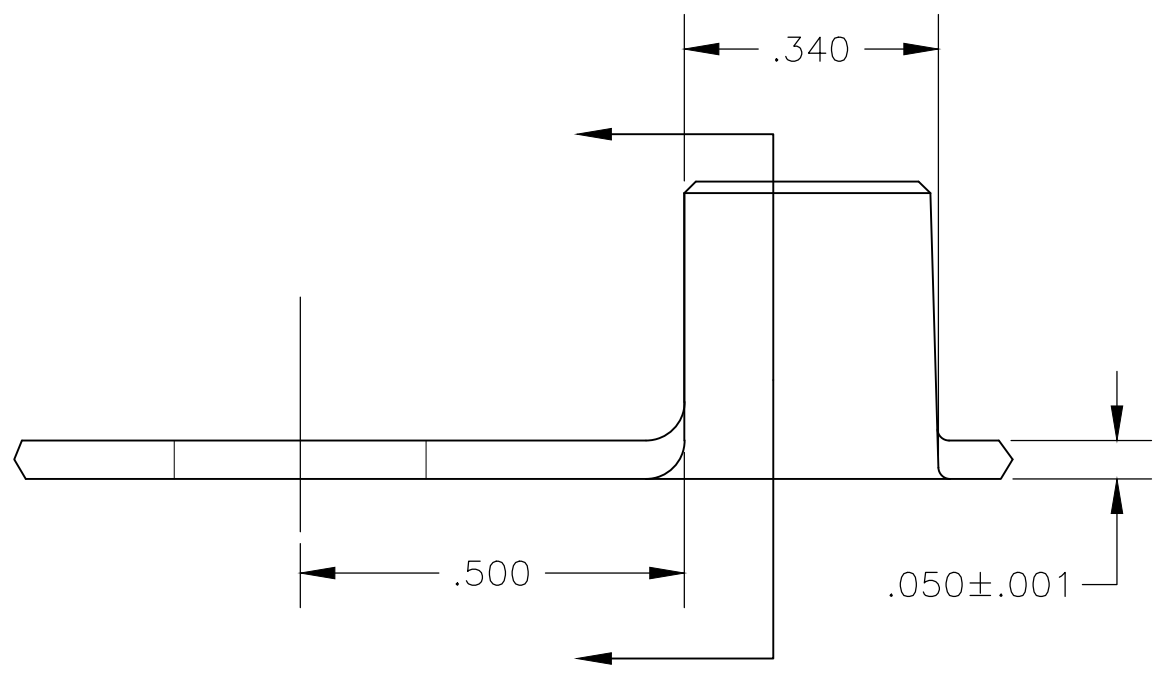

OBSOLETE	TEMP H00 COPPER	△3	1742456-3	△4
	TEMP H00 COPPER		1742456-2	
OBSOLETE	— 082 BRASS —	△3	1742456-1	
MATERIAL			PART NUMBER	

THIS DRAWING IS A CONTROLLED DOCUMENT.		DWN	JR RUTH	01AUG06	STE TE Connectivity				
DIMENSIONS: INCHES		CHK	D DECKER	01AUG06					
TOLERANCES UNLESS OTHERWISE SPECIFIED:		APVD	D DECKER	01AUG06	NAME				
0 PLC ± - 1 PLC ± - 2 PLC ± - 3 PLC ± .010 4 PLC ± - ANGLES ± 1°		PRODUCT SPEC		RING TONGUE					
MATERIAL SEE TABLE		FINISH		△2		RESTRICTED TO			
		APPLICATION SPEC		SIZE			CAGE CODE	DRAWING NO	RESTRICTED TO
		WEIGHT		A3			00779	C-1742456	—
		CUSTOMER DRAWING			SCALE	4:1	SHEET	1 OF 1	REV
								B4	