

REVISIONS					
REV	ECO	DESCRIPTION	DATE	BY	APPR
A1	--	RELEASE NEW DRAWING	16/NOV/22	MILO	TOMMY

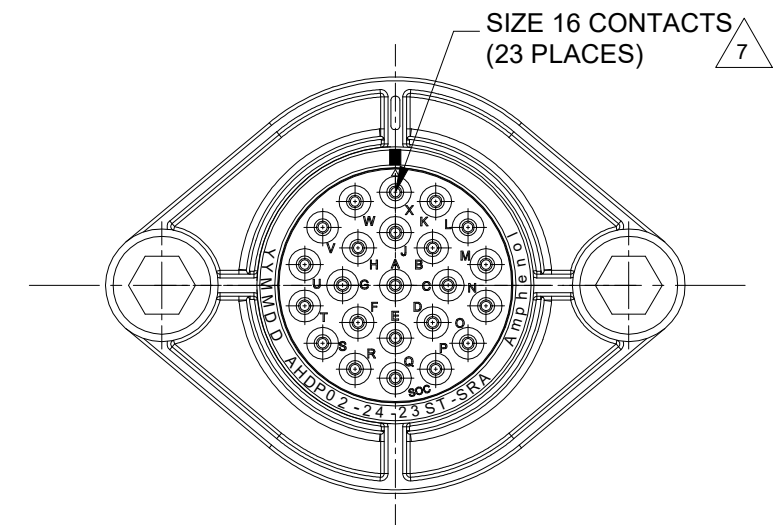
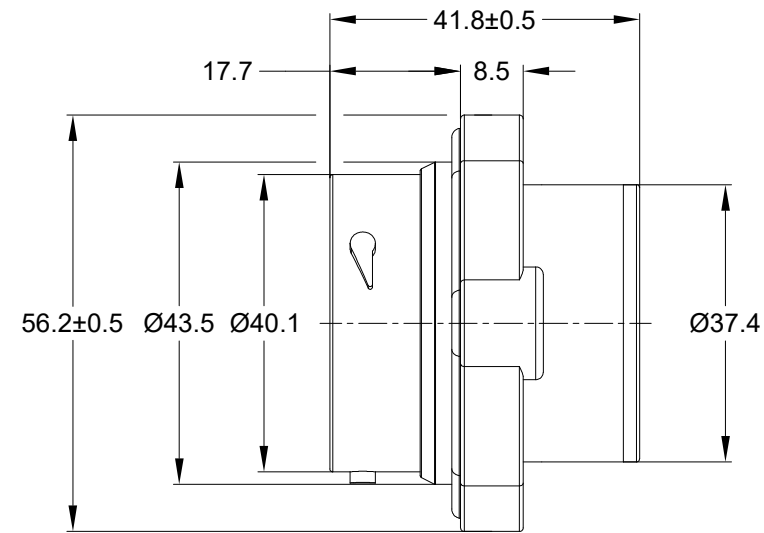
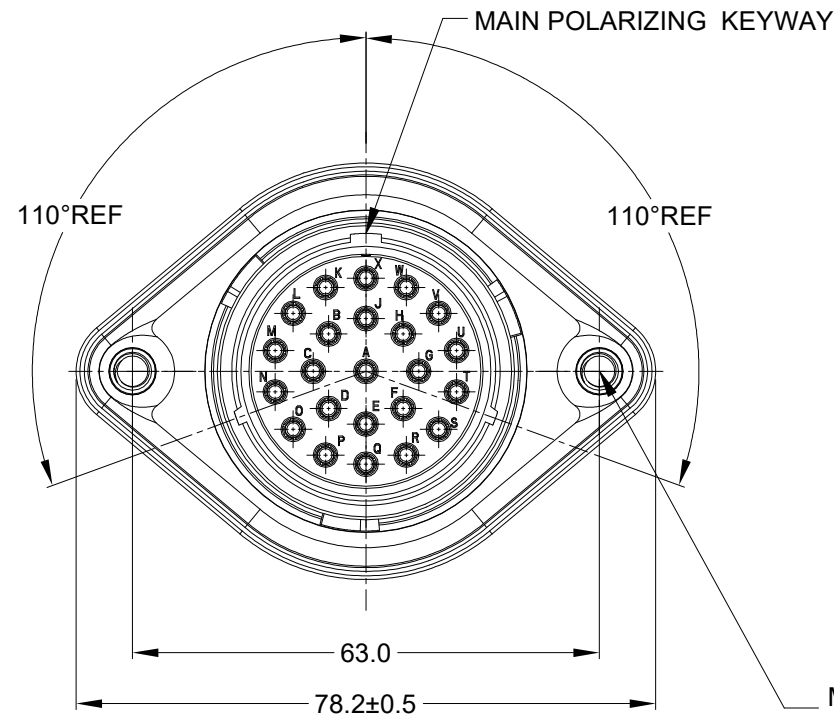

M5X0.8-6H 8mm(2X) DEEP  
THREADED INSERT

RECOMMENDED TORQUE  
VALUES: 1.9-2.2 N.m

NOTES: UNLESS OTHERWISE SPECIFIED

- MATERIAL:  
HOUSING: THERMOPLASTIC; BLACK  
SEAL: SILICONE RUBBER  
THREADED INSERT: STAINLESS STEEL
- MODIFICATIONS: SMOOTH RING ADAPTER (SRA);  
THIN WALL DIA. WIRE SEAL  
SEALED PANEL MOUNT
- SPECIFICATIONS:  
3.1 OPERATING TEMPERATURE: -55°C TO +125°C.  
3.2 DIELECTRIC WITHSTANDING VOLTAGE: LESS THAN 2  
MILLIAMPS CURRENT LEAKAGE @ 1500 VOLTS AC.  
3.3 INSULATION RESISTANCE: 1000 MEGOHM MIN @ 25°C.  
3.4 MOISTURE RESISTANCE:  
IP68(IM OF WATER FOR A PERIOD OF 24 HOURS, MATED  
CONDITION);  
IP69K(MATED CONDITION)  
3.5 MATING CYCLE DURABILITY: 100 CYCLES  
3.6 RoHS COMPLIANT
- MATING PART: AHDP06-24-23P\* (\* = SEAL TYPE)
- ALL DIMENSIONS ARE FOR REFERENCE USE ONLY.
- RECEPTACLE IS SUPPLIED WITH DUST CAP (NOT SHOWN)

7 CONTACT SIZE AND WIRE RANGE:

CONTACT SIZE	MIN.INSUL O.D	MAX.INSUL O.D	WIRE RANGE mm <sup>2</sup>
16	2.23mm (.088in)	2.69mm (.106in)	14-20AWG (2.0-0.5mm <sup>2</sup> )

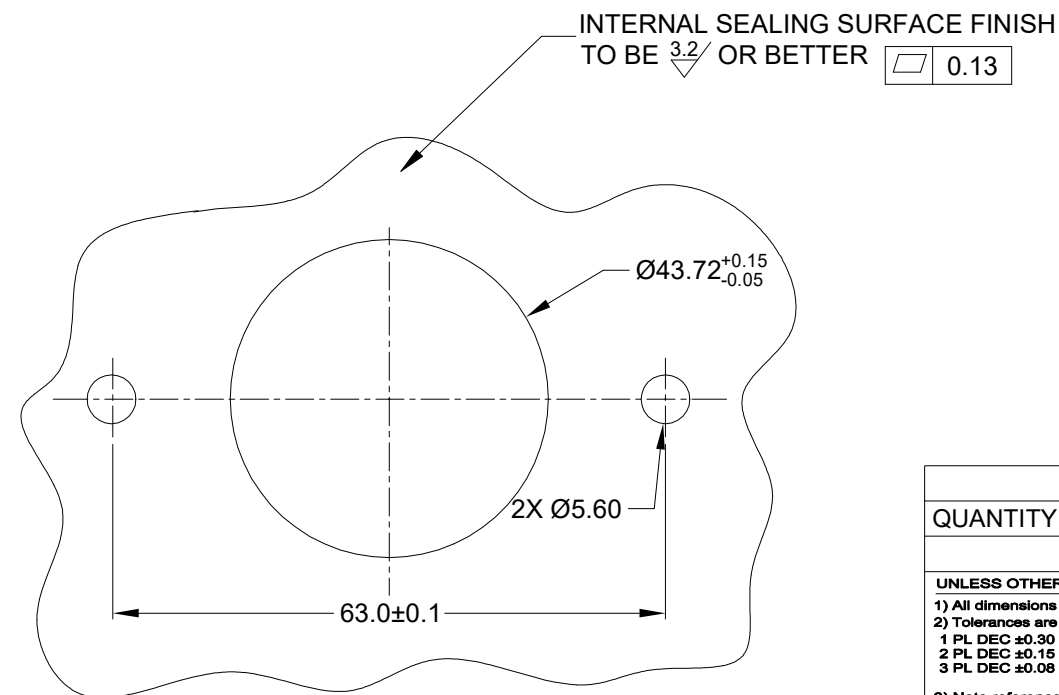

RECOMMENDED PANEL  
MOUNTING HOLE

RECOMMENDED PANEL  
THICKNESS: 1.6 TO 4.7MM

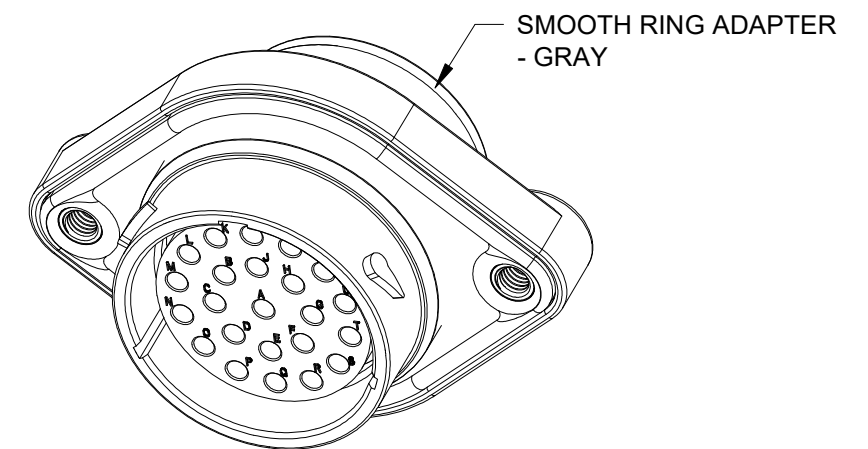

QUANTITY	AHDP02-24-23ST-SRA	DESCRIPTION	ITEM
<b>MATERIALS LIST</b>			
UNLESS OTHERWISE SPECIFIED 1) All dimensions are in metric(mm). 2) Tolerances are as follows: 1 PL DEC ±0.30 Fractions ±1/64 2 PL DEC ±0.15 Angles ±1° 3 PL DEC ±0.08		SIGNATURES DRAWN: MILO.DONG CHECKED: SULLENZHANG ENGINEER: APPROVAL: TOMMY.XIE CUSTOMER:	DATE 16/NOV/22 17/NOV/22 18/NOV/22
MATERIAL SPECIFICATIONS: <b>WEIGHT: 62.6g</b>		<b>Amphenol</b> Sine Systems - www.amphenol-sine.com 44724 Morley Drive Clinton Township, MI 48036	
PROCESS SPECIFICATIONS:		23POS,RECEPTACLE,SOCKET,SZ24, THIN WIRE SEAL,SRA,PANELMATE AHDP	
NEXT ASSY:		SIZE <b>B C-</b>	DWG NO: <b>AHDP02-24-23ST-SRA</b>
		SCALE: NONE	REVISION <b>A1</b>
		DURAMATE SHEET 1 OF 1	

TITLE: 23POS.RECEPTACLE,SOCKET,SZ24,THIN WIRE SEAL,SRA,PANELMATE AHDP  
DWG NO: AHDP02-24-23ST-SRA  
REV: A1  
SH: 1  
OF: 1