

MS5 シリーズ  
SERIES

85°C 高さ5mm品  
85°C 5mm Height

・85°C 1000時間品。  
Load Life : 85°C 1000 hours.

生産中止品  
OBSOLETE PRODUCTS

RoHS  
compliance

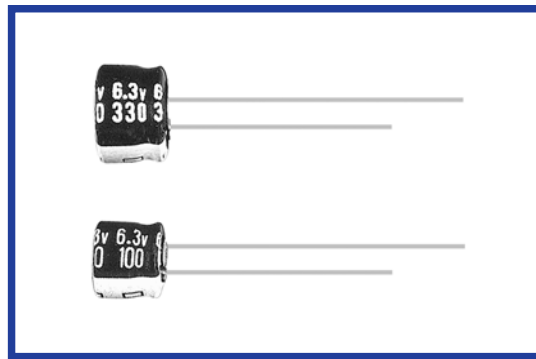

◆規格表 / SPECIFICATIONS

項目 Items	特性 Characteristics																											
カテゴリ温度範囲 Category Temperature Range	-40~+85°C																											
定格電圧範囲 Rated Voltage Range	4~50Vdc																											
静電容量許容差 Capacitance Tolerance	±20% (20°C, 120Hz)																											
漏れ電流 Leakage Current (MAX)	I=0.01CV又は3μAのいずれか大なる値以下 (定格電圧印加2分後) I=0.01CV or 3μA whichever is greater. (After 2 minutes application of rated voltage) I=漏れ電流(μA) Leakage Current      C=静電容量(μF) Capacitance      V=定格電圧(Vdc) Rated Voltage																											
損失角の正接 (tanδ) Dissipation Factor (MAX)	<table border="1"> <tr> <td>定格電圧(Vdc) Rated Voltage</td> <td>4</td> <td>6.3</td> <td>10</td> <td>16</td> <td>25</td> <td>35</td> <td>50</td> <td>(20°C, 120Hz)</td> </tr> <tr> <td>tanδ</td> <td>0.35</td> <td>0.26</td> <td>0.22</td> <td>0.18</td> <td>0.16</td> <td>0.14</td> <td>0.12</td> <td></td> </tr> </table>	定格電圧(Vdc) Rated Voltage	4	6.3	10	16	25	35	50	(20°C, 120Hz)	tanδ	0.35	0.26	0.22	0.18	0.16	0.14	0.12										
定格電圧(Vdc) Rated Voltage	4	6.3	10	16	25	35	50	(20°C, 120Hz)																				
tanδ	0.35	0.26	0.22	0.18	0.16	0.14	0.12																					
耐久性 Endurance	85°C中で1000時間定格電圧(リップル重畳)印加後、下記項目を満足すること。 After applying rated voltage with rated ripple current for 1000 hrs at 85°C, the capacitors shall meet the following requirements. <table border="1"> <tr> <td>静電容量変化率 Capacitance Change</td> <td>初期値の±25%以内 Within ±25% of the initial value.</td> </tr> <tr> <td>損失角の正接 Dissipation Factor</td> <td>規格値の200%以下 Not more than 200% of the specified value.</td> </tr> <tr> <td>漏れ電流 Leakage Current</td> <td>規格値以下 Not more than the specified value.</td> </tr> </table>	静電容量変化率 Capacitance Change	初期値の±25%以内 Within ±25% of the initial value.	損失角の正接 Dissipation Factor	規格値の200%以下 Not more than 200% of the specified value.	漏れ電流 Leakage Current	規格値以下 Not more than the specified value.																					
静電容量変化率 Capacitance Change	初期値の±25%以内 Within ±25% of the initial value.																											
損失角の正接 Dissipation Factor	規格値の200%以下 Not more than 200% of the specified value.																											
漏れ電流 Leakage Current	規格値以下 Not more than the specified value.																											
低温特性 Low Temperature Stability (インピーダンス比) Impedance Ratio (MAX)	<table border="1"> <tr> <td>定格電圧(Vdc) Rated Voltage</td> <td>4</td> <td>6.3</td> <td>10</td> <td>16</td> <td>25</td> <td>35</td> <td>50</td> <td>(120Hz)</td> </tr> <tr> <td>Z(-25°C)/Z(20°C)</td> <td>7</td> <td>6</td> <td>4</td> <td>4</td> <td>3</td> <td>2</td> <td>2</td> <td></td> </tr> <tr> <td>Z(-40°C)/Z(20°C)</td> <td>15</td> <td>12</td> <td>10</td> <td>8</td> <td>6</td> <td>4</td> <td>4</td> <td></td> </tr> </table>	定格電圧(Vdc) Rated Voltage	4	6.3	10	16	25	35	50	(120Hz)	Z(-25°C)/Z(20°C)	7	6	4	4	3	2	2		Z(-40°C)/Z(20°C)	15	12	10	8	6	4	4	
定格電圧(Vdc) Rated Voltage	4	6.3	10	16	25	35	50	(120Hz)																				
Z(-25°C)/Z(20°C)	7	6	4	4	3	2	2																					
Z(-40°C)/Z(20°C)	15	12	10	8	6	4	4																					

◆リップル電流補正係数 / MULTIPLIER FOR RIPPLE CURRENT

周波数係数 Frequency coefficient

周波数 (Hz) Frequency	60(50)	120	500	1k	10k≤
0.47~1μF	0.50	1.00	1.20	1.30	1.50
1.5~6.8μF	0.65	1.00	1.20	1.30	1.50
10~68μF	0.80	1.00	1.20	1.30	1.50
100~470μF	0.80	1.00	1.10	1.15	1.20

◆副記号 / OPTION

	記号 Code
PETスリーブ PET Sleeve	EFC

◆呼称方法 / PART NUMBER

□□□	MS5	□□□□□	M	□□□	□□	D×L
定格電圧 Rated Voltage	シリーズ名 Series	静電容量 Capacitance	静電容量許容差 Capacitance Tolerance	副記号 Option	リード加工記号 Lead Forming	ケースサイズ Case Size

◆寸法図 / DIMENSIONS

(mm)

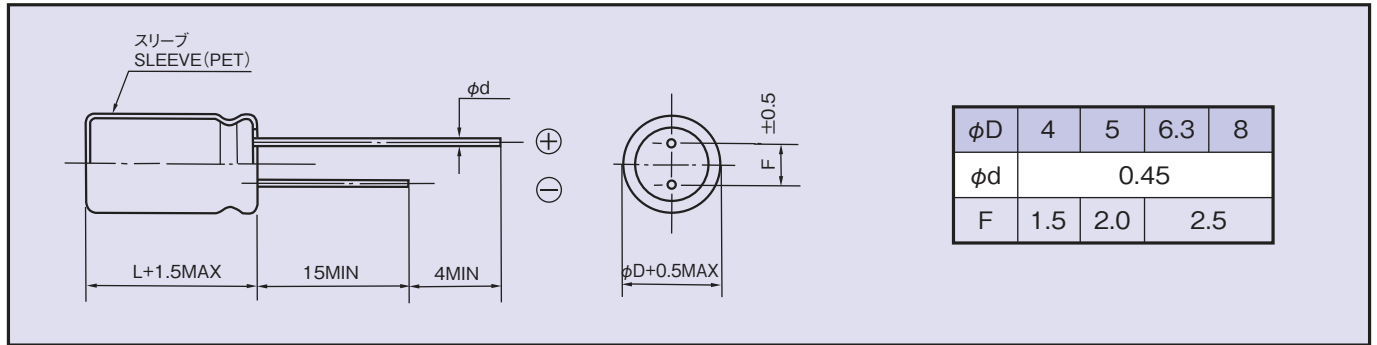

◆標準品一覧表 / STANDARD SIZE

Size  $\phi D \times L$ (mm), Rated Ripple Current (mA r.m.s./85°C, 120Hz)

定格電圧 Vdc 静電容量 Cap(μF)	4		6.3		10		16	
	Size	Ripple	Size	Ripple	Size	Ripple	Size	Ripple
4.7							4×5	11
6.8					4×5	10	4×5	13
10			4×5	14	4×5	16	4×5	18
15			4×5	18	4×5	22	5×5	26
22	4×5	20	4×5	22	5×5	30	5×5	35
33	4×5	27	5×5	34	5×5	45	6.3×5	51
47	4×5	37	5×5	37	6.3×5	50	6.3×5	65
68	5×5	45	6.3×5	55	6.3×5	59	6.3×5	70
100	5×5	62	6.3×5	62	6.3×5	80	8×5	92
220	6.3×5	74	8×5	120	8×5	145		
330	8×5	145	8×5	145				
470	8×5	181						

定格電圧 Vdc 静電容量 Cap(μF)	25		35		50	
	Size	Ripple	Size	Ripple	Size	Ripple
0.47					4×5	6
0.68					4×5	7
1					4×5	8.6
1.5					4×5	8.7
2.2			4×5	9	4×5	9.1
3.3	4×5	11	4×5	12	4×5	13
4.7	4×5	13	4×5	14	5×5	20
6.8	4×5	19	5×5	20	6.3×5	26
10	5×5	27	5×5	27	6.3×5	31
15	5×5	33	6.3×5	35	6.3×5	39
22	6.3×5	46	6.3×5	46	8×5	60
33	6.3×5	54	8×5	65	8×5	80
47	6.3×5	65	8×5	85		
68	8×5	90				
100	8×5	120				