

ELECTRICAL SPECIFICATIONS:

- |   |                              |   |                  |
|---|------------------------------|---|------------------|
| 1.0 TURNS RATIO (P6-P5-P4) :                        | (J6-J3)                      | : 1CT : 1CT ± 3%                          |                  |
|   | (P3-P2-P1) :                 | (J2-J1)                                   | : 1CT : 1CT ± 3% |
| 2.0 INDUCTANCE (P6-P4)                              |                              | : 350uH MIN. @ 0.1V , 100KHz, 8mA DC Bias |                  |
|   | (P3-P1)                      | : 350uH MIN. @ 0.1V, 100KHz, 8mA DC Bias  |                  |
| 3.0 LEAKAGE INDUCTANCE P6-P4 (WITH J6 AND J3 SHORT) |                              | : 0.3 MAX. @ 1MHZ                         |                  |
|   | P3-P1 (WITH J2 AND J1 SHORT) | : 0.3 MAX. @ 1MHZ                         |                  |
| 4.0 INTERWINDING CAPACITANCE (P6,P5,P4) TO (J6,J3)  |                              | : 30pf MAX @ 1MHZ                         |                  |
|   | (P3,P2,P1) TO (J2,J1)        | : 30pf MAX. @ 1MHZ                        |                  |
| 5.0 DC RESISTANCE (J6-J3)=(J2-J1)                   |                              | : 1.2 ohms Max.                           |                  |

NOTES

1.0 PINS WITHOUT ELECTRICAL CONNECTION ARE OMITTED.

InNet Technologies Inc.

<http://www.innet-tech.com>

Stewart Connector Systems

<http://www.stewartconnector.com>

SHEET  
1 OF 4

DRAWING NO. SI-10022 REV. 07

6.0 RETURN LOSS:  $\langle P6-P4 \rangle = 100 \text{ OHMS}$  AND  $\langle P1-P3 \rangle = 100 \text{ OHM REF.}$   
1MHz TO 30MHz : 18dB MIN.  
60MHz TO 80MHz : 12dB MIN.

NOTE: 100 OHMS CONNECTED TO  $\langle J2-J1 \rangle$  OR  $\langle J6-J3 \rangle$ .

7.0 VOLTAGE WITHSTAND:  
 $\langle J1, J2 \rangle$  TO  $\langle P1, P3 \rangle$  : 1500 VAC  
 $\langle J3, J6 \rangle$  TO  $\langle P4, P6 \rangle$  : 1500 VAC

8.0 INSERTION LOSS:  $RS=RL=100 \text{ ohms}$   
100KHz TO 100MHz : 1.1 dB TYP

9.0 RISE TIME:  $RS=100 \text{ OHMS}$  AND  $RL = 100 \text{ OHMS}$   
OUTPUT VOLTAGE = 1 V peak : 3.0 nS MAX  
PULSE WIDTH= 112nS : 3.0 nS MAX

10.0 CROSS TALK:  
1MHz TO 100MHz : 40 dB TYP

11.0 COMMON TO COMMON MODE ATTENUATION:  
30MHz TO 100MHz : 35dB TYP

InNet Technologies Inc.

<http://www.innet-tech.com>

Stewart Connector Systems

<http://www.stewartconnector.com>

SHEET  
2 OF 4

DRAWING NO. SI-10022 REV. 07

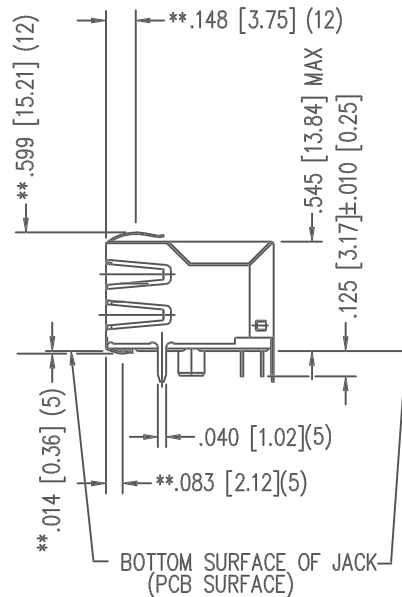
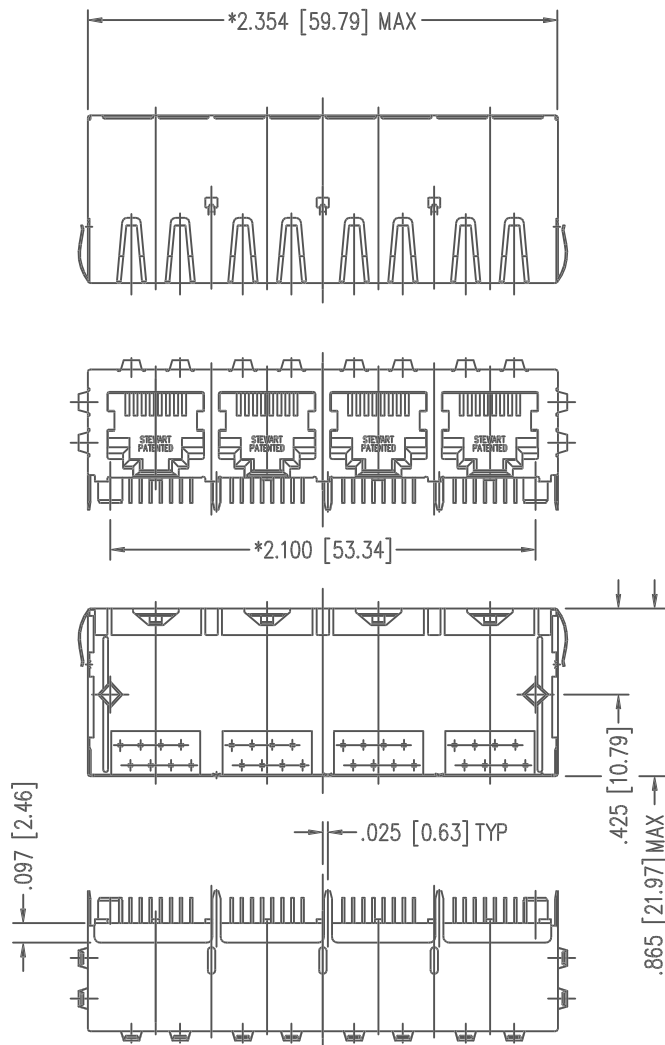

NOTES:

- TOLERANCES COMPLY WITH F.C.C. DIMENSION REQUIREMENTS
- DIMENSIONS SHOWN WITH "\*" TO BE CENTRAL ABOUT CENTER LINE
- "\*\*\*" ON DIMENSION INDICATES HIGHEST POINT OF BEAM
- DIMENSIONS SHOWN ARE SUBJECT TO CHANGE WITHOUT NOTICE
- PIN NOT ELECTRICALLY CONNECTED MAYBE OMITTED. SEE ELECTRICAL DRAWING FOR OMITTED PINS.

AVAILABLE WITH:

- STANDARD 50 MICRO-INCH SELECTIVE GOLD PLATING (30 AVAILABLE UPON REQUEST)

Ref: SS-668804S-A-PG4 -BC

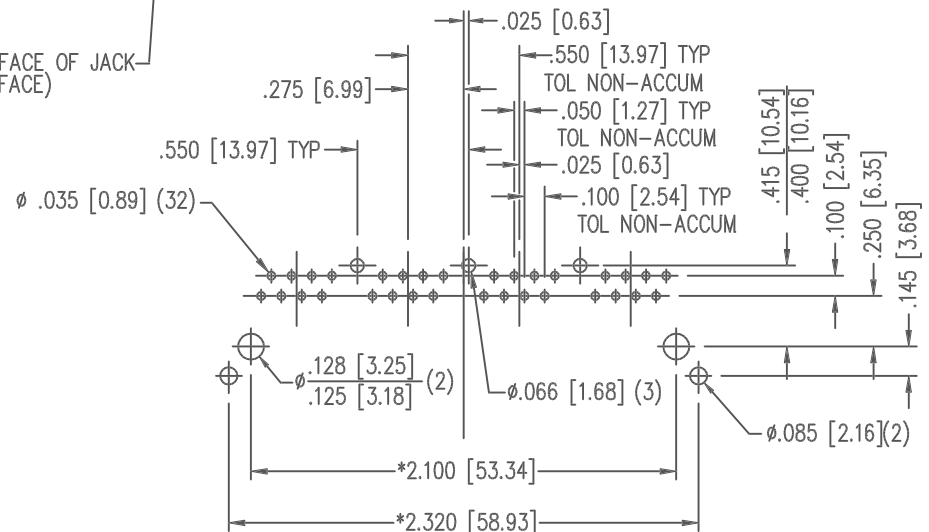

P.C.B. RECOMMENDED HOLE LAYOUT  
SEEN FROM COMPONENT SIDE  
TOLERANCE ±.003 [0.08] UNLESS OTHERWISE SPECIFIED

CT720035X1/24-001701

InNet Technologies Inc.

<http://www.innet-tech.com>

Stewart Connector Systems

<http://www.stewartconnector.com>

SHEET  
3 of 4

DRAWING NO. SI-10022 REV. 01

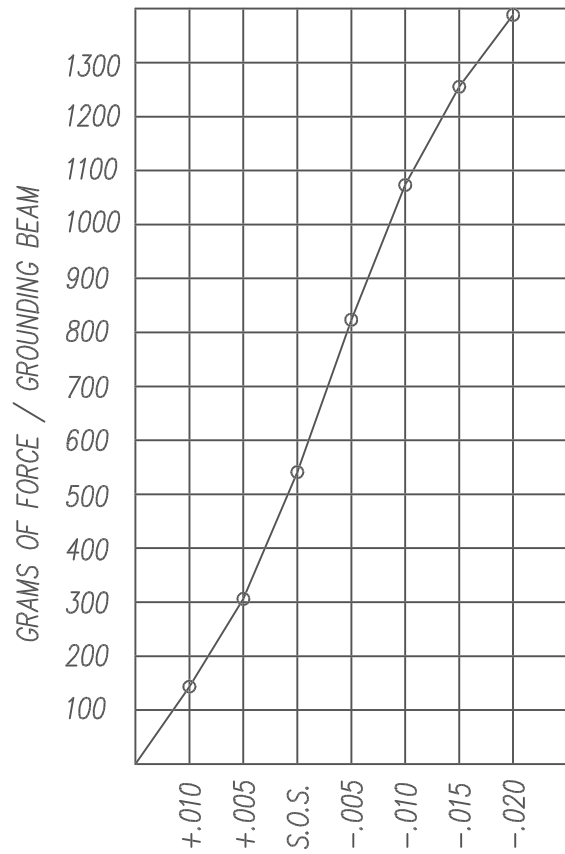

PANEL GROUNDING BEAM DEFLECTION  
S.O.S. = SUGGESTED OPENING SIZE

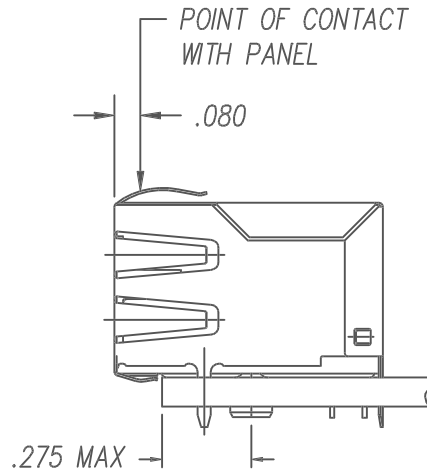

THE SUGGESTED PANEL OPENING IS INTENDED TO GIVE THE USER THE ABILITY TO HAVE REASONABLE JACK / PANEL CLEARANCES YET MAINTAIN RELIABLE GROUNDING CAPABILITY. THESE VARIABLES CAN BE ADJUSTED IN EITHER DIRECTION BUT MAY CARRY SOME CONSEQUENCES IN THE FORM OF LOWER MATING FORCES OR TIGHTER ASSEMBLY TOLERANCES. FORCE VALUES ON THE GRAPH ARE GENERAL AVERAGES TAKEN AT THE POINT OF CONTACT SHOWN ABOVE. THE SUGGESTED PANEL OPENING INCLUDES APPROXIMATELY .020 CLEARANCE ON THE SIDES AND TOP AND .005 ON THE BOTTOM.

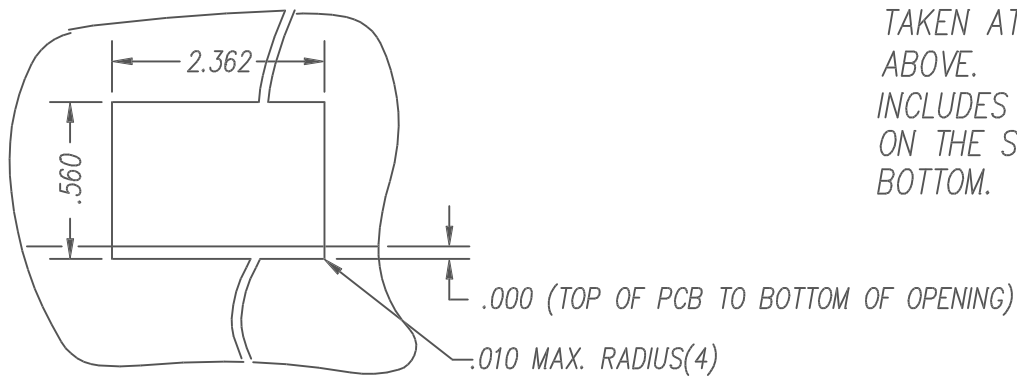

SUGGESTED PANEL OPENING

CT720035X1/24-001701

InNet Technologies Inc.

<http://www.innet-tech.com>

Stewart Connector Systems

<http://www.stewartconnector.com>

SHEET  
4 of 4

DRAWING NO. SI-10022 REV. 01