

## High Voltage 8-CH LED Driver

### General Description

The RT8561A is a 40V 8-CH LED driver capable of delivering 30mA to each channel with 10 LEDs (3.6V per diode), total of 80 LEDs with one driver. The RT8561A is a current mode boost converter operated at 1MHz, wide  $V_{IN}$  range covers from 6V to 24V and the on-chip current switch is rated at 2.5A.

The PWM output voltage loop regulates the LED pins to 0.6V with an auto-adjustment circuit allowing voltage mismatches between LED strings. The RT8561A automatically detects and disconnects any unconnected and/or broken strings during operation from PWM loop to prevent  $V_{OUT}$  from over voltage.

The 1.5% matched LED currents on all channels are simply programmed with a resistor or a current sink. Both analog dimming and digitally controlled PWM dimming are supported by the RT8561A. Analog dimming is linearly controlled by an external voltage. With an on-chip output clamping amplifier and a 300k $\Omega$  resistor, PWM dimming signal is easily low-pass filtered to an analog dimming signal with one external capacitor for noise-free PWM dimming. A very high contrast ratio true digital PWM dimming can be achieved by driving ACTL pin with a PWM signal.

Other protecting features include programmable output over voltage protection, LED current limit, PWM switch current limit and thermal shutdown.

The RT8561A is packaged with a tiny footprint package of WQFN-24L 4x4 packages.

### Ordering Information

RT8561A □ □

- Package Type  
QW : WQFN-24L 4x4 (W-Type)
- Lead Plating System  
G : Green (Halogen Free and Pb Free)

Note :

Richtek products are :

- ▶ RoHS compliant and compatible with the current requirements of IPC/JEDEC J-STD-020.
- ▶ Suitable for use in SnPb or Pb-free soldering processes.

### Features

- High Voltage :  $V_{IN}$  up to 24V,  $V_{OUT}$  up to 40V, Driving up to 80 x 3.6V LEDs (10 each channel)
- Channel Current Programmable 10mA to 30mA and Matched to 1.5%
- Current Mode PWM 1MHz Boost Converter
- Easy Analog and Digital Dimming Control
- Programmable Soft Start
- Automatic Detecting Unconnected and/or Broken Channel
- Programmable Over Voltage Protection
- Disconnects LED in Shutdown
- Providing High Accuracy Digital Dimming by PWM at ACTL Pin
- $V_{IN}$  Under Voltage Lockout
- Over Temperature Protection
- Current Limiting Protection
- Small 24-Lead WQFN Package
- RoHS Compliant and Halogen Free

### Applications

- UMPC and Notebook Computer Backlight
- GPS, Portable DVD Backlight
- Desk Lights and Room Lighting

### Pin Configurations

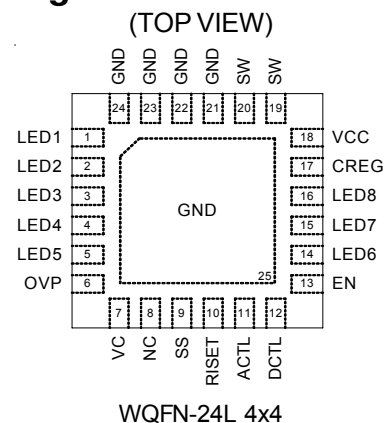

### Marking Information

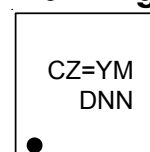

CZ= : Product Code  
YMDNN : Date Code

Typical Application Circuit

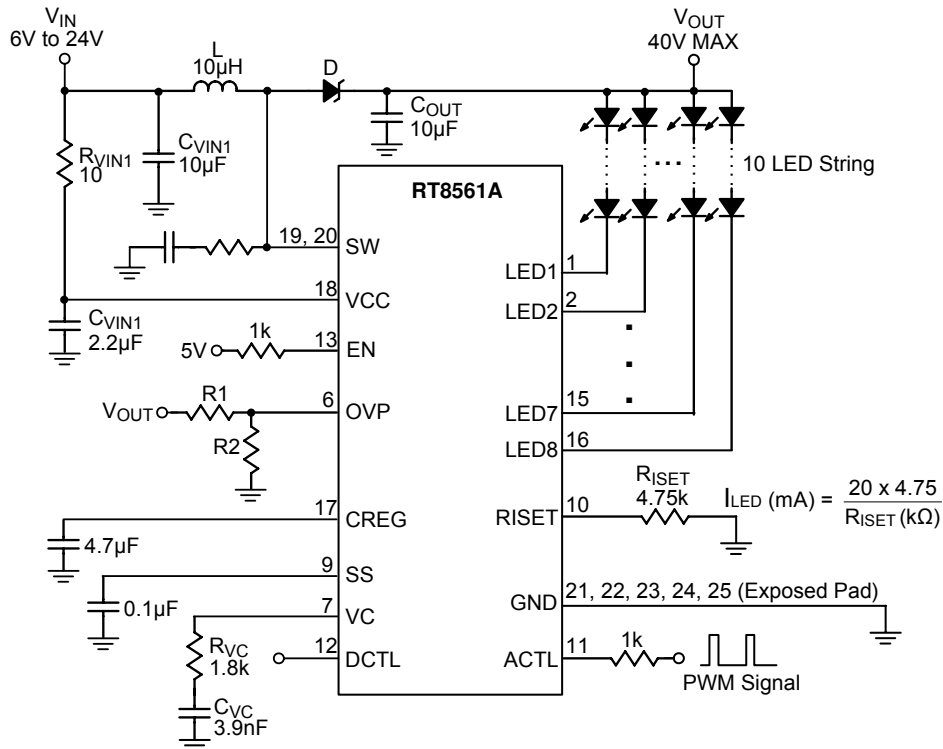

Figure 1. 1MHz, 20mA Full Scale Current PWM Dimming Control

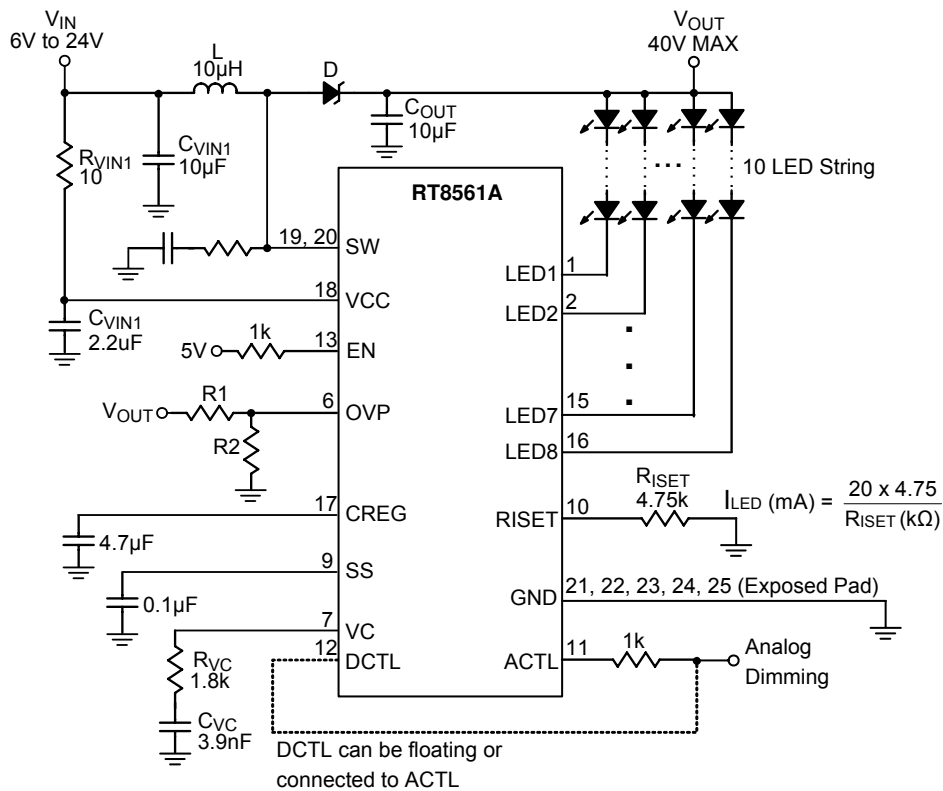

Figure 2. 1MHz, 20mA Full Scale Current Analog Dimming Control

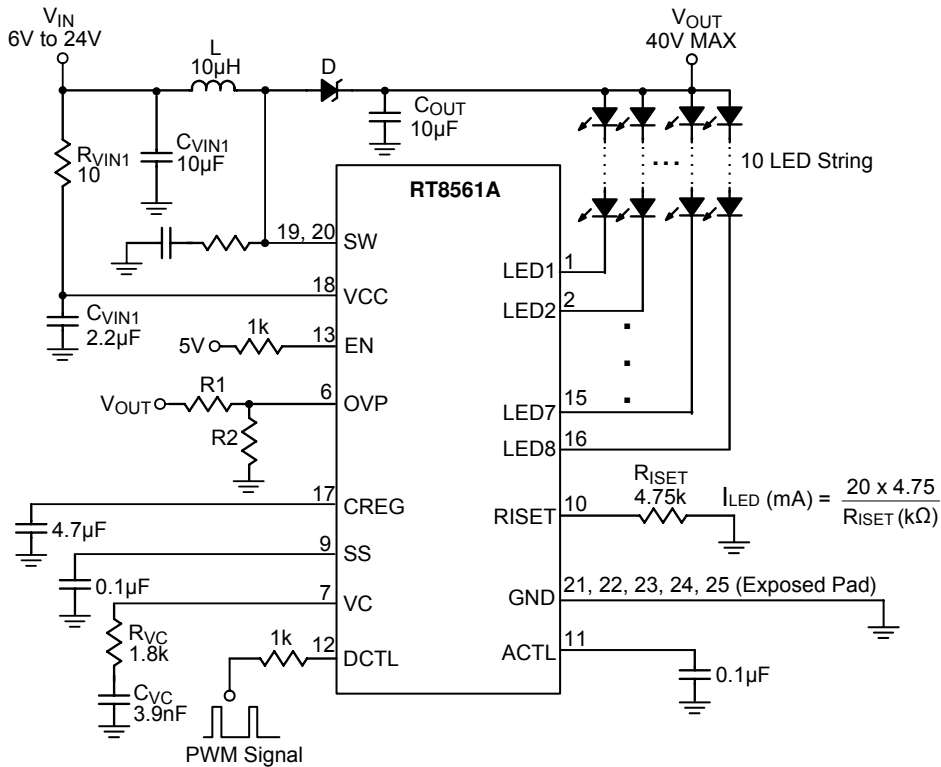
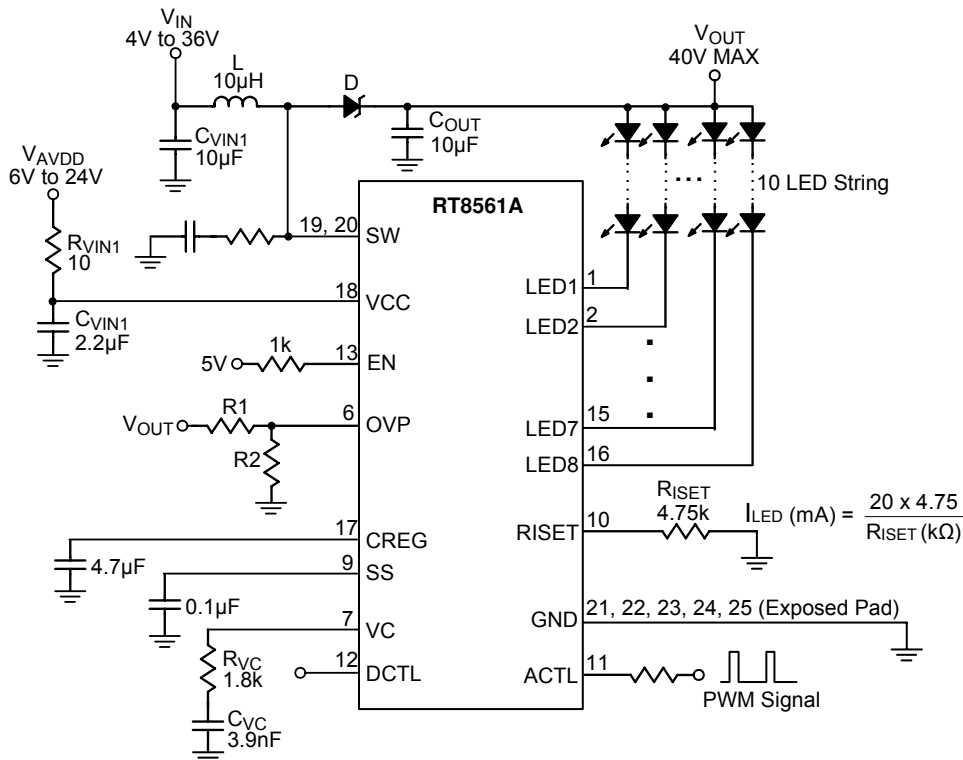

Figure 3. 1MHz, 20mA Full Scale Current PWM to Analog Dimming Control



Note :

1. Due to the limitation of maximum duty 5V input can support typically to  $V_{OUT} = 33V$ .
2. Due to the limitation of maximum duty 4V input can support typically to  $V_{OUT} = 26V$ .

Figure 4. Wide Range VIN Application by Connecting VCC Pin to LCD Driver Power AVDD

Function Block Diagram

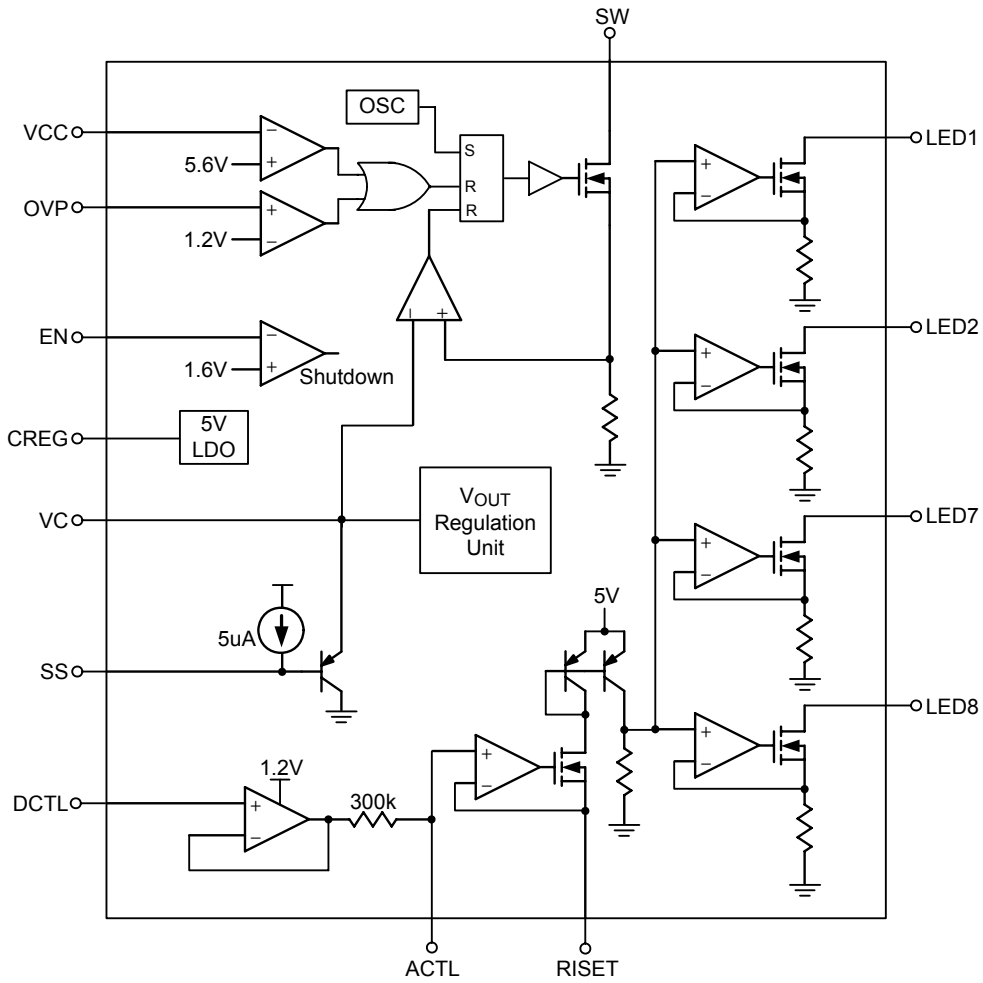

**Functional Pin Description**

Pin No.	Pin Name	Pin Function
1, 2, 3, 4, 5	LED1, LED2, LED3, LED4, LED5	Channel 1 to Channel 5 LED current sink. Leave the pin unconnected if not used.
6	OVP	Over Voltage Protection. PWM boost converter turns off when $V_{OVP}$ goes higher than 1.2V.
7	VC	PWM boost converter loop compensation node.
8	NC	No Internal Connection.
9	SS	Soft Start Pin, a capacitor of at least 10nF is required for soft start.
10	RISET	A resistor or a current from DAC on this pin programs the full LED current.
11	ACTL	Analog/Digital dimming control. When using analog dimming, $I_{LED} \text{ (mA)} = \frac{20 \times 4.75}{RISET \text{ (k}\Omega\text{)}} \text{ for } V_{ACTL} \geq 1.2V.$
12	DCTL	By adding a 0.1 $\mu$ F filtering capacitor on the ACTL pin, the PWM dimming signal on the DCTL pin will be averaged out and converted into analog dimming signal on the ACTL pin.
13	EN	Chip enable pin, when pulled low, chip is in shutdown mode.
14, 15, 16	LED6, LED7, LED8	Channel 6 to Channel 8 LED current sink. Leave the pin unconnected if not used.
17	CREG	1 $\mu$ F capacitor should be placed on this pin to stabilize the 5V output of the internal regulator. This regulator is for chip internal use only.
18	VCC	Power supply of the chip. For good bypass, a low ESR capacitor is required.
19, 20	SW	PWM boost converter switch node.
21, 22, 23, 24, 25 (Exposed Pad)	GND	Ground pin of the chip. The exposed pad must be soldered to a large PCB and connected to GND for maximum power dissipation.

## Absolute Maximum Ratings (Note 1)

• Supply Voltage, VCC	-----	-0.3V to 28V
• SW Pin Voltage at Switching Off	-----	-0.3V to 45V
• LED1 to LED8 Pin	-----	-0.3V to 35V
• DCTL, ACTL, EN, OVP Pin Voltage	-----	-0.3V to 5.5V
• Power Dissipation, P <sub>D</sub> @ T <sub>A</sub> = 25°C		
WQFN-24L 4x4	-----	1.923W
• Package Thermal Resistance (Note 2)		
WQFN-24L 4x4, θ <sub>JA</sub>	-----	52°C/W
WQFN-24L 4x4, θ <sub>JC</sub>	-----	7°C/W
• Junction Temperature	-----	150°C
• Lead Temperature (Soldering, 10 sec.)	-----	260°C
• Storage Temperature Range	-----	-65°C to 150°C
• ESD Susceptibility (Note 3)		
HBM (Human Body Mode)	-----	2kV
MM (Machine Mode)	-----	200V

## Recommended Operating Conditions (Note 4)

• Supply Input Voltage, VCC	-----	6V to 24V
• Junction Temperature Range	-----	-40°C to 125°C
• Ambient Temperature Range	-----	-40°C to 85°C

## Electrical Characteristics

(V<sub>CC</sub> = 17V, T<sub>A</sub> = 25°C, unless otherwise specified)

Parameter	Symbol	Test Conditions	Min	Typ	Max	Unit
Supply Current	I <sub>VCC</sub>	V <sub>C</sub> ≤ 0.2V (Switching off)	--	3	5	mA
V <sub>IN</sub> Under Voltage Lockout Threshold	V <sub>UVLO</sub>	V <sub>IN</sub> Rising	--	5.6	5.95	V
		V <sub>IN</sub> Falling	--	4.9	--	
Shutdown Current	I <sub>SHDN</sub>	V <sub>EN</sub> ≤ 0.7V	--	--	10	μA
EN Threshold Voltage	Logic-High	V <sub>EN_H</sub>	1.6	--	5	V
	Logic-Low	V <sub>EN_L</sub>	--	--	1	
PWM Threshold Voltage	Logic-High	V <sub>PWM_H</sub>	1.3	--	5	V
	Logic-Low	V <sub>PWM_L</sub>	--	--	0.15	
EN Pin Input Current	I <sub>EN</sub>	V <sub>EN</sub> ≤ 5V	--	--	0.1	μA
<b>LED Current Programming</b>						
LED Current	I <sub>LED</sub>	2V > V <sub>LED</sub> > 0.6V, R <sub>ISET</sub> = 4.75kΩ, V <sub>ACTL</sub> > 1.2V	19	20	21	mA
LEDs Current Matching		2V > V <sub>LED</sub> > 0.6V, R <sub>ISET</sub> = 4.75kΩ, V <sub>ACTL</sub> > 1.2V, Calculating (I <sub>(MAX)</sub> - I <sub>(MIN)</sub> ) / I <sub>Average</sub> × 100%	--	--	1.5	%
RISET Pin Voltage	V <sub>RISET</sub>	3.6kΩ ≤ R <sub>ISET</sub> ≤ 9.6kΩ, V <sub>ACTL</sub> > 1.2V	1.17	1.2	1.23	V
Input Current of ACTL	I <sub>ACTL</sub>	0.3V ≤ V <sub>ACTL</sub> ≤ 1.2V	--	1	2	μA

Parameter	Symbol	Test Conditions	Min	Typ	Max	Unit
Threshold of ACTL	V <sub>ACTL</sub>	LED Current Off	--	0.2	--	V
Input Current of DCTL	I <sub>DCTL</sub>	0.3V ≤ V <sub>DCTL</sub> ≤ 5.5V	--	1	2	μA
V <sub>LED</sub> Threshold		Un-connection	--	0.1	--	V
<b>PWM Boost Converter</b>						
Switching Frequency			0.8	1	1.2	MHz
Minimum On Time			--	100	--	ns
Regulated V <sub>LED</sub>		Highest Voltage LED String	0.5	0.6	0.7	V
Amplifier (gm) Output Current		2.4V > VC > 0.2V	--	±15	--	μA
VC Threshold		PWM Switch Off	0.1	0.2	--	V
SW R <sub>DS(ON)</sub>			--	0.3	0.5	Ω
SW Current Limit	I <sub>LIM</sub>		2.5	--	--	A
SW Maximum Duty			80	88	--	%
<b>OVP &amp; Soft-Start</b>						
OVP Threshold	V <sub>OVP</sub>		1.1	1.2	1.3	V
OVP Input Current	I <sub>OVP</sub>	V <sub>OVP</sub> ≤ 3V	--	--	50	nA
Soft-Start Current	I <sub>SS</sub>	V <sub>SS</sub> ≤ 2.5V	3	5	8	μA
Thermal Shutdown Temperature	T <sub>SD</sub>		--	150	--	°C
Thermal Shutdown Hysteresis			--	20	--	°C

**Note 1.** Stresses beyond those listed “Absolute Maximum Ratings” may cause permanent damage to the device. These are stress ratings only, and functional operation of the device at these or any other conditions beyond those indicated in the operational sections of the specifications is not implied. Exposure to absolute maximum rating conditions may affect device reliability.

**Note 2.** θ<sub>JA</sub> is measured at T<sub>A</sub> = 25°C on a high effective thermal conductivity four-layer test board per JEDEC 51-7. θ<sub>JC</sub> is measured at the exposed pad of the package.

**Note 3.** Devices are ESD sensitive. Handling precaution is recommended.

**Note 4.** The device is not guaranteed to function outside its operating conditions.

Typical Operating Characteristics

Efficiency vs. Input Voltage

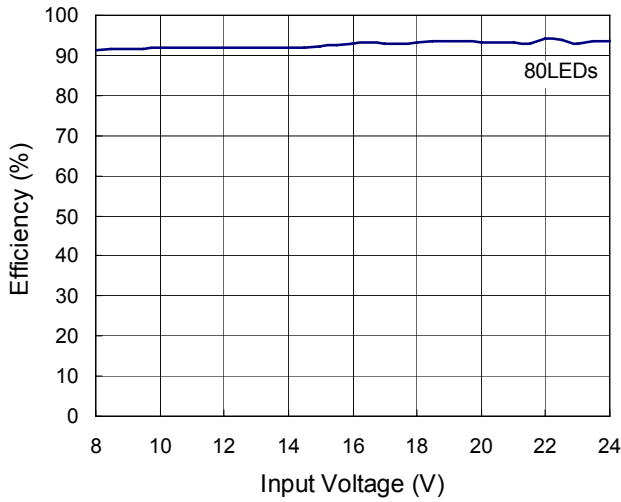

LED Current vs. Input Voltage

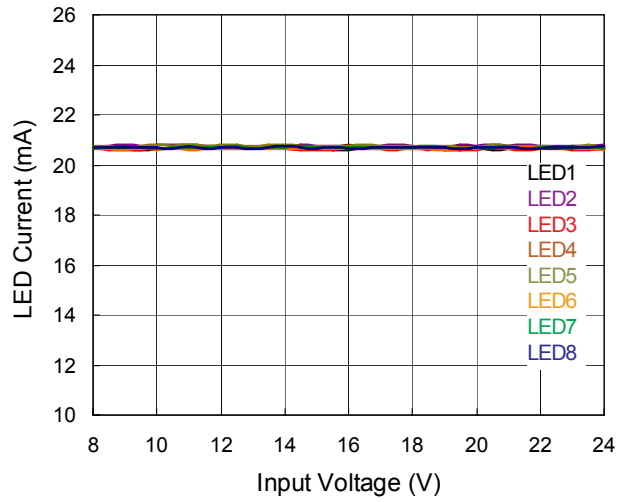

LED Current vs. Temperature

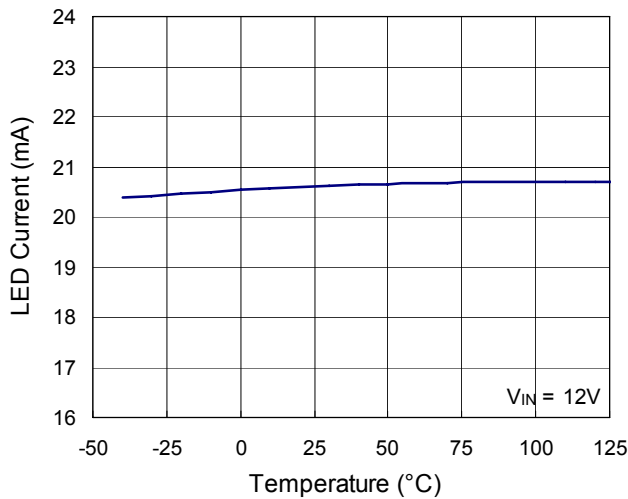

V<sub>RISSET</sub> vs. Temperature

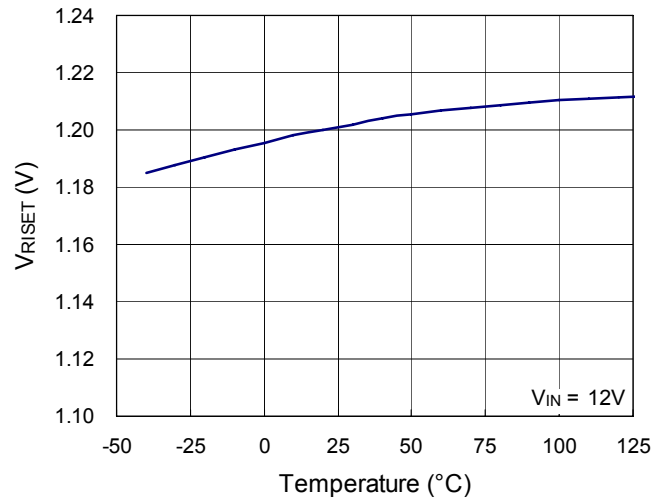

V<sub>RISSET</sub> vs. Input Voltage

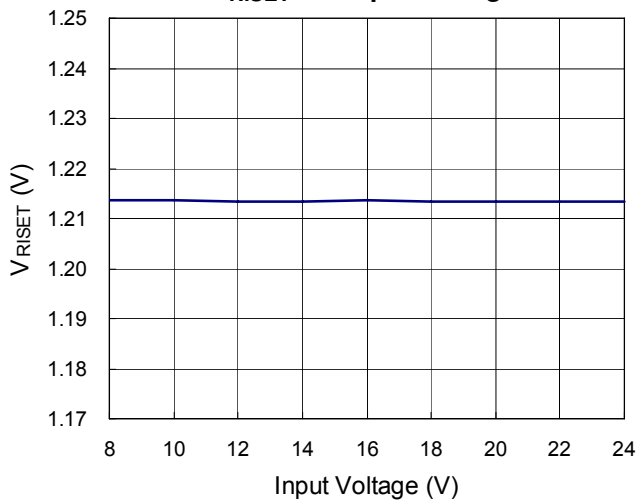

LED Current vs. ACTL PWM Duty Cycle

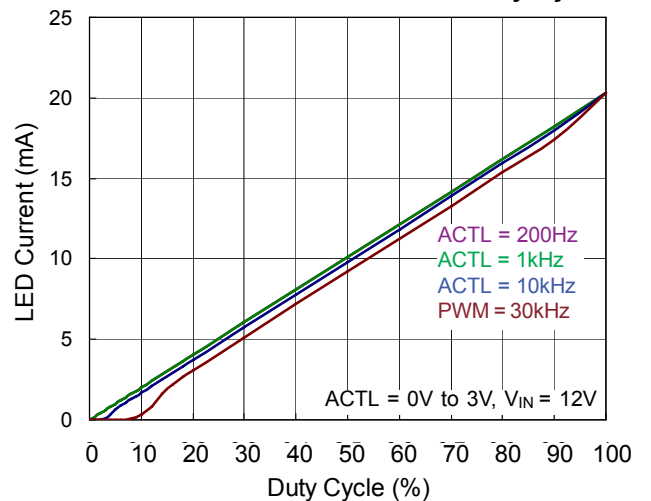



**LED Current vs. DCTL PWM Duty Cycle**

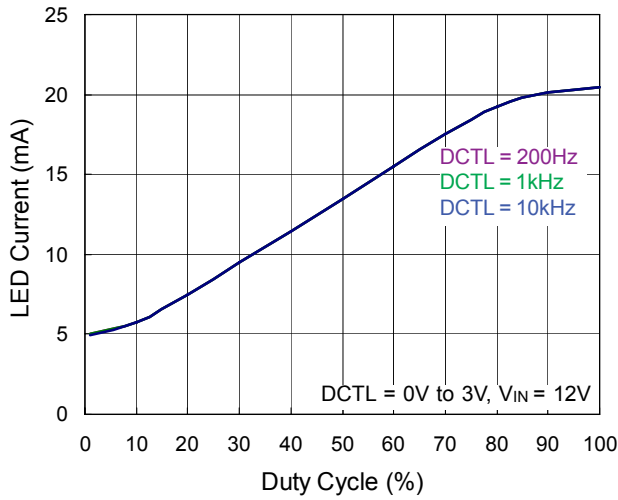

**LED Current vs. ACTL Analog Voltage**

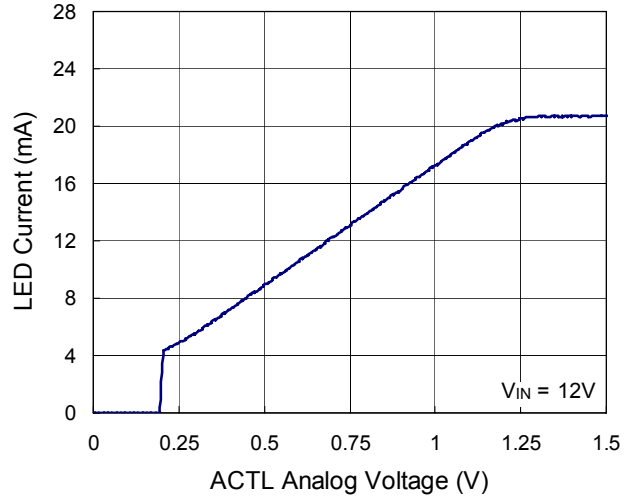

**Frequency vs. Input Voltage**

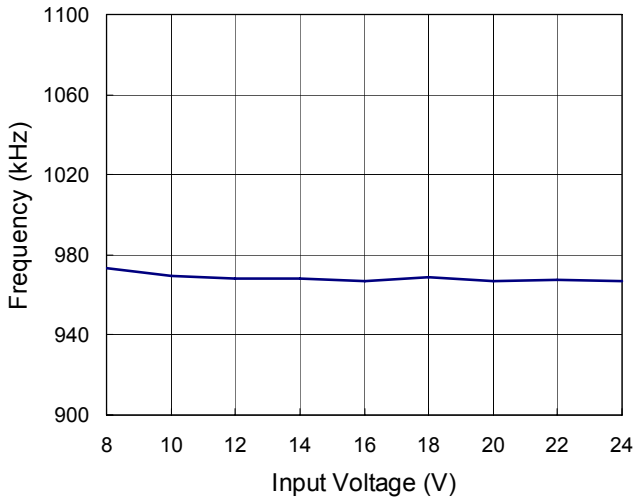

**Shutdown Current vs. Input Voltage**

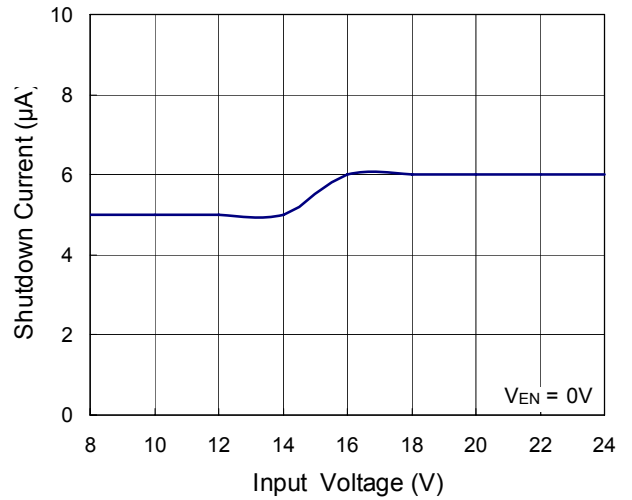

**Supply Current vs. Input Voltage**

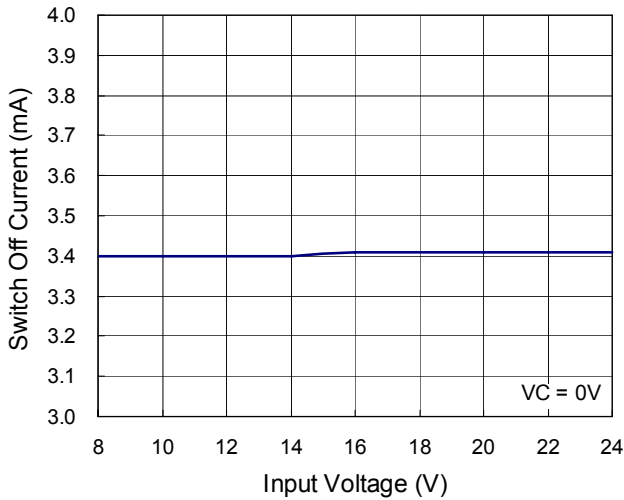

**SS Current vs. Temperature**

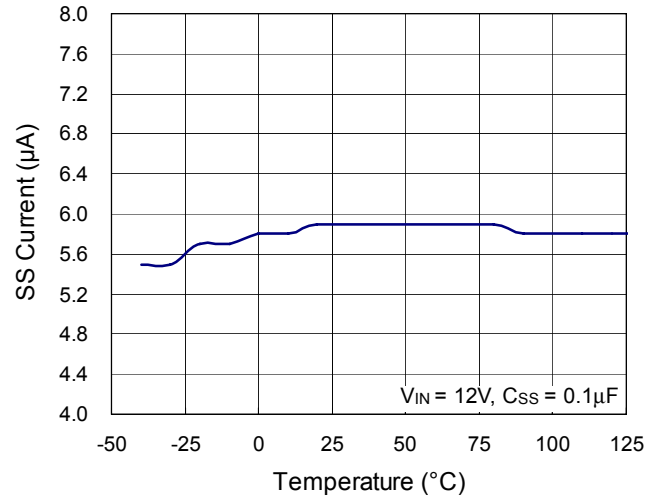

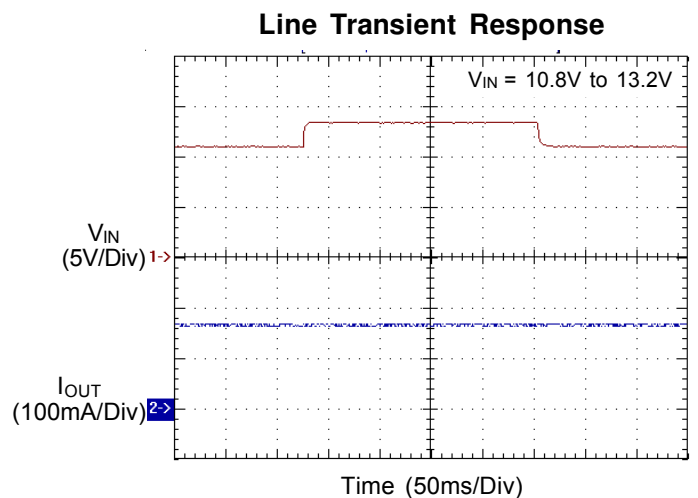
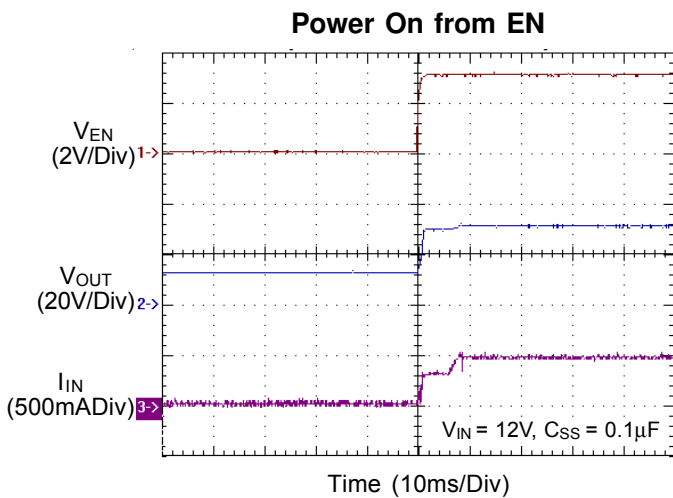
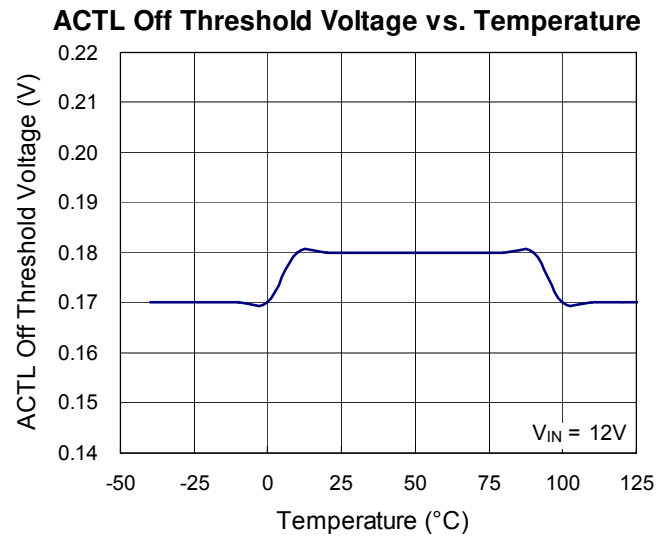
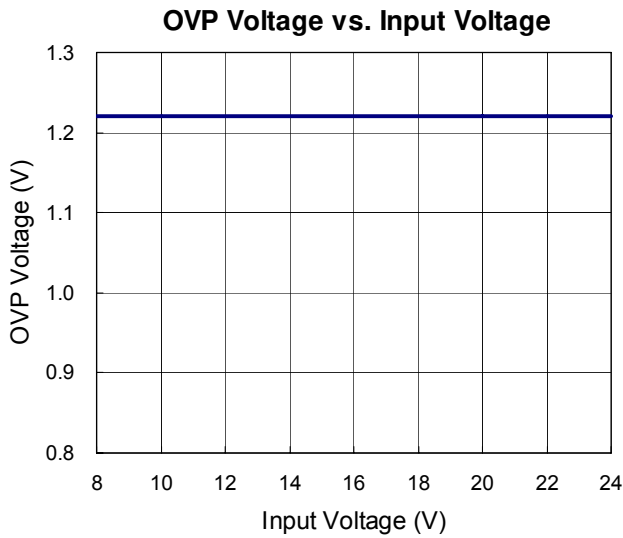
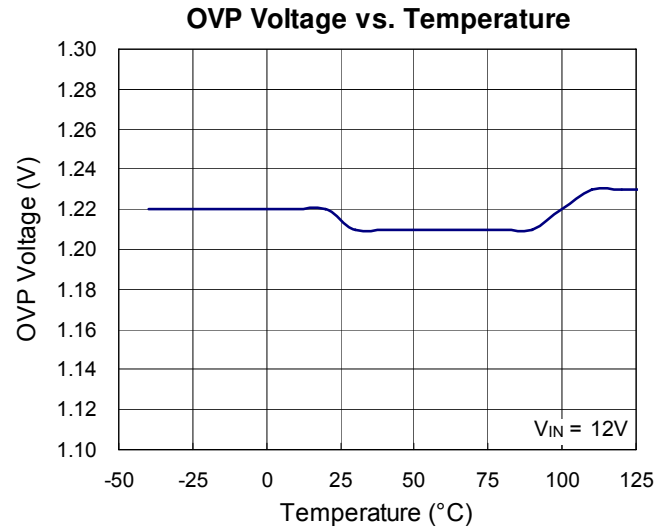
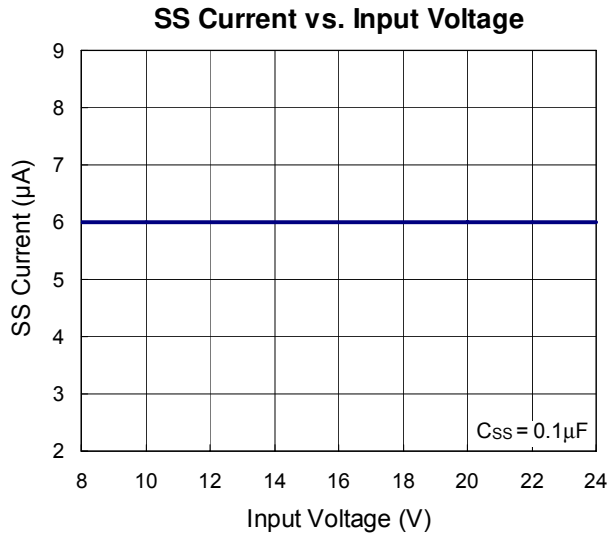

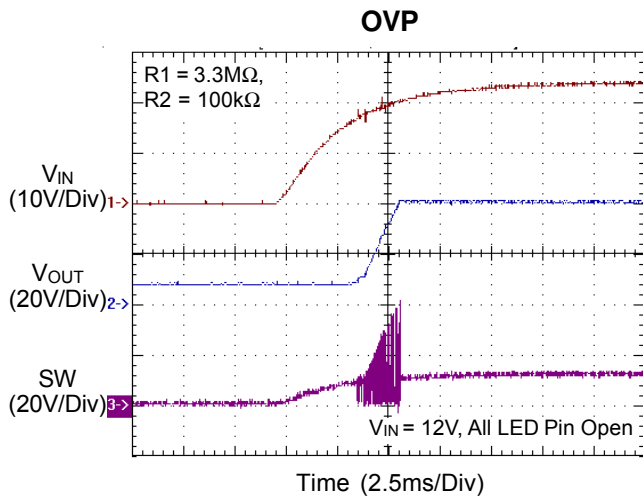

## Applications Information

The RT8561A is a current mode boost converter operated at 1MHz to power up to 80 white LEDs with a programmable current for uniform intensity. The part integrates current sources, soft-start, and easy analog and digital dimming control. The protection block provides the circuitry for over temperature, over-voltage and current limit protection features.

### Input UVLO

The input operating voltage range of the RT8561A is 6V to 24V. An input capacitor at the VIN pin can reduce ripple voltage. It is recommended to use a ceramic 10µF or larger capacitance as the input capacitor. This IC provides an under voltage lockout (UVLO) function to enhance the stability when startup. The UVLO threshold of input voltage rising is set at 5.6V and falling is set at 4.9V typically.

### Power Sequence

Please refer to the below Figure 5 and Figure 6. The recommended power on sequence is that the PWM ready before EN and/or VIN ready. If not, the soft-start function will be disabled. As to power off sequence, the EN/VIN must be pulled low within 10ms to prevent "Hard-Start" shown as Figure 7.

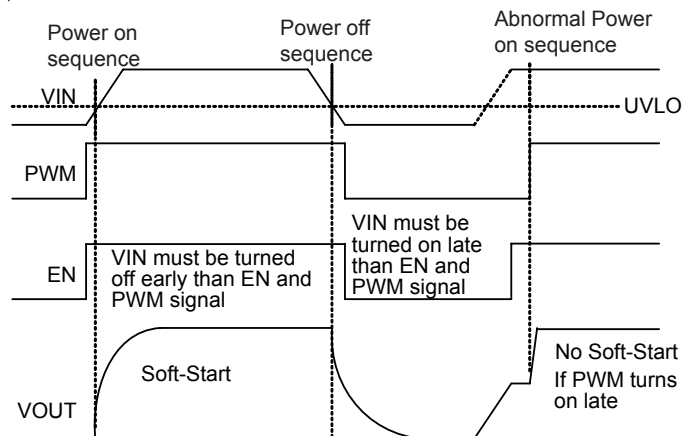

Figure 6. Power On Sequence Control by VIN

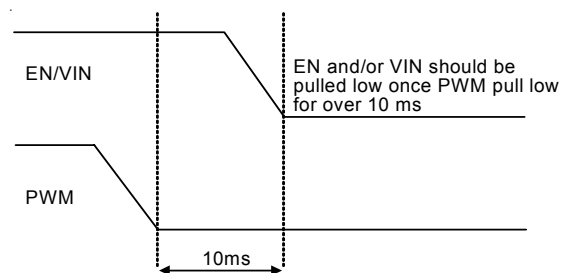

Figure 7. To Prevent "Hard-Start" Sequence

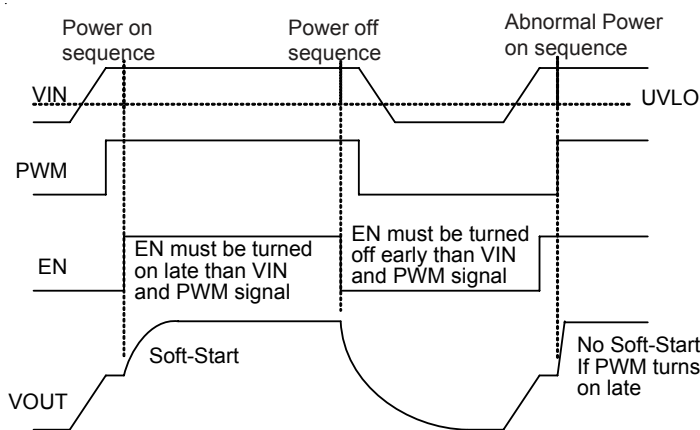

Figure 5. Power On Sequence Control by EN

### Soft-Start

The RT8561A employs a soft-start feature to limit the inrush current. The soft-start circuit prevents the excessive inrush current and input voltage droop. The soft-start time is determined by capacitor C<sub>SS</sub> connected to SS with 5µA constant current to charge C<sub>SS</sub>. The value of capacitor C<sub>SS</sub> is user-defined to satisfy the designer's requirement.

### LED Connection

The RT8561A equips 8-CH LED drivers and each channel supports up to 10 LEDs. The 8 LED strings are connected from VOUT to pin 1, 2, 3, 4, 5, 14, 15, and 16 respectively. If one of the LED channel is not used, the LED pin should be opened directly.

### Setting and Regulation of LED Current

The LED current can be calculated by the following equation :

$$I_{LED}(mA) = \frac{20 \times 4.75}{R_{SET}(k\Omega)}$$

Where, the RISET is the resistor between RISET pin and GND.

This setting is the reference for the LED current at LED1-8 and represents the sensed LED current for each string. The DC/DC converter regulates the LED current according to the setting.

**Brightness Control**

The RT8561A features both analog and digital dimming control. Analog dimming is linearly controlled by an external voltage ( $0.3V < V_{ACTL} < 1.2V$ ). With an on-chip output clamping amplifier and a 300kΩ resistor, PWM dimming signal is easily low-pass filtered to an analog dimming signal with one external capacitor for noise-free PWM dimming. A very high contrast ratio true digital PWM dimming can be achieved by driving ACTL pin with a PWM signal and the suggested PWM frequency is from 100Hz to 10kHz. Dimming frequency can be sufficiently adjusted from 100Hz to 30kHz. However, LED current cannot be 100% proportional to duty cycle especially for high frequency and low duty ratio because of physic limitation caused by inductor rising time. Refer to Figure 8 and Table 1.

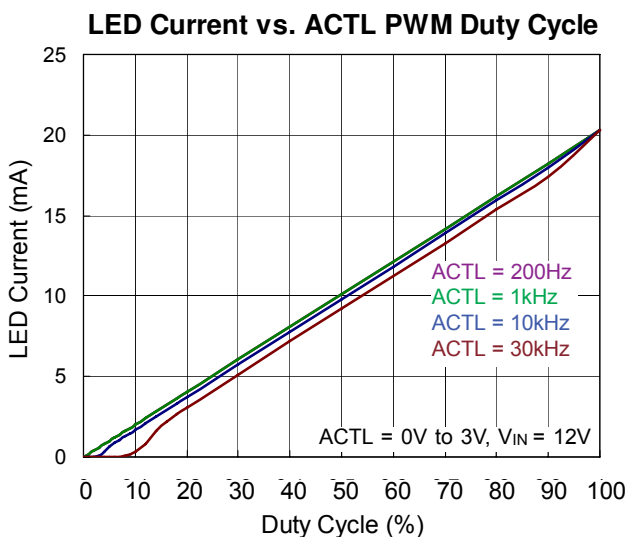

Figure 8. LED Current vs. ACTL PWM Dimming Duty Cycle

**Table 1.**

Dimming Frequency (Hz)	Duty (Min.)	Duty (Max.)
$100 < f_{PWM} \leq 200$	0.16%	100%
$200 < f_{PWM} \leq 500$	0.40%	100%
$500 < f_{PWM} \leq 1k$	0.80%	100%
$1k < f_{PWM} \leq 2k$	1.60%	100%
$2k < f_{PWM} \leq 5k$	4.00%	100%
$5k < f_{PWM} \leq 10k$	8.00%	100%
$10k < f_{PWM} \leq 20k$	16.00%	100%

Note : The minimum duty in Table 1 is based on the application circuit and does not consider the deviation of current linearity.

**Over Voltage Protection**

The RT8561A equips over voltage protection (OVP) function. When the voltage at the OVP pin reaches a threshold of approximately 1.2V, the MOSFET drive output (SW) will turn “OFF”. The MOSFET drive output (SW) will turn “ON” again once the voltage at OVP drops below the threshold of approximately 1.2V.

So, the output voltage can be clamped at a certain voltage level and it can be calculated by the following equation :

$$V_{OUT, OVP} = V_{OVP} \times \left(1 + \frac{R1}{R2}\right)$$

Where

R1 and R2 are the voltage divider connected to OVP pin.

$V_{OVP}$  is typically 1.2V.

If at least one string is in normal operation, the controller will automatically ignore the open strings and continue to regulate the current for the string(s) in normal operation.

**Current Limit Protection**

The RT8561A can limit the peak current to achieve over current protection. The RT8561A senses the inductor current through SW pin in the switch-on period. The duty cycle depends on the current sense signal summing with the internal slope compensation compared to the VC signal. The internal N-MOSFET will be turned off when the current signal is larger than the VC signal. In the off period, the inductor current will descend. The internal MOSFET is turned on by the oscillator in the next beginning cycle.

## Over Temperature Protection

The RT8561A has over temperature protection (OTP) function to prevent the excessive power dissipation from overheating. The OTP will shut down switching operation if the junction temperature exceeds 150°C. Main converter starts switching after junction temperature cools down approximately 20°C.

## Inductor Selection

The value of the output inductor (L), where the transition from discontinuous to continuous mode occurs is approximated by the following equation :

$$L = \frac{(V_{OUT} - V_{IN}) \times V_{IN}^2}{2 \times I_{OUT} \times f \times V_{OUT}^2}$$

Where,

$V_{OUT}$  = maximum output voltage.

$V_{IN}$  = minimum input voltage.

f = operating frequency.

$I_{OUT}$  = sum of current from all LED strings.

$\eta$  is the efficiency of the power converter.

The boost converter operates in discontinuous mode over the entire input voltage range when the L1 inductor value is less than this value L. With an inductance greater than L, the converter operates in continuous mode at the minimum input voltage and may be discontinuous at higher voltages.

The inductor must be selected with a saturated current rating that is greater than the peak current provided by the following equation :

$$I_{PEAK} = \frac{V_{OUT} \times I_{OUT}}{\eta \times V_{IN}} + \frac{V_{IN} \times T}{2 \times L} \left( \frac{V_{OUT} - V_{IN}}{V_{OUT}} \right)$$

## Diode Selection

Schottky diode is a good choice for an asynchronous Boost converter due to the small forward voltage. However, for power dissipation, reverse voltage rating and pulsating peak current are the important parameters of Schottky diode selection. Choose a suitable diode whose reverse voltage rating is greater than the maximum output voltage.

## Capacitor Selection

The input capacitor reduces current spikes from the input supply and minimizes noise injection to the converter. For most applications, a 10uF ceramic capacitor is sufficient. A value higher or lower may be used depending on the noise level from the input supply and the input current to the converter.

It is recommended to choose a ceramic capacitor bases on the output voltage ripple requirements. The minimum value of the output capacitor  $C_{OUT}$  is approximately given by the following equation :

$$C_{OUT} = \frac{(V_{OUT} - V_{IN}) \times I_{OUT}}{\eta \times V_{RIPPLE} \times V_{OUT} \times f}$$

## Layout Guideline

PCB layout is very important for designing power switching converter circuits. The following layout guide lines should be strictly followed for best performance of the RT8561A.

- ▶ The power components L, D,  $C_{VIN1}$ ,  $C_{OUT1}$  and  $C_{OUT2}$  must be placed as close as possible to reduce the ac current loop. The PCB trace between power components must be short and wide as possible due to large current flow through these trace during operation.
- ▶ Place L and D connected to SW pin as close as possible. The trace should be short and wide as possible.
- ▶ It is recommend to place  $C_{VIN2}$  close to VIN pin.
- ▶ Pin7 is the compensation point to adjust system stability. Place the compensation components to pin7 as close as possible, no matter the compensation is RC or capacitance.

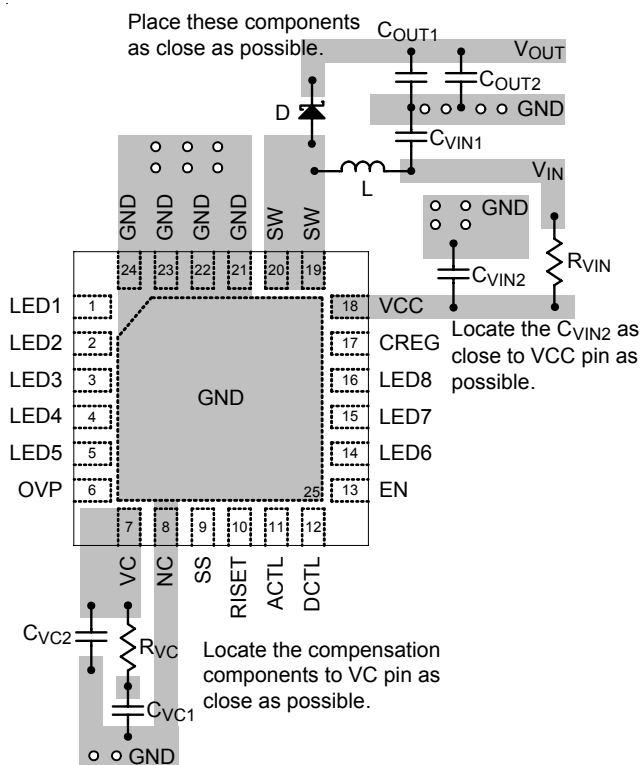
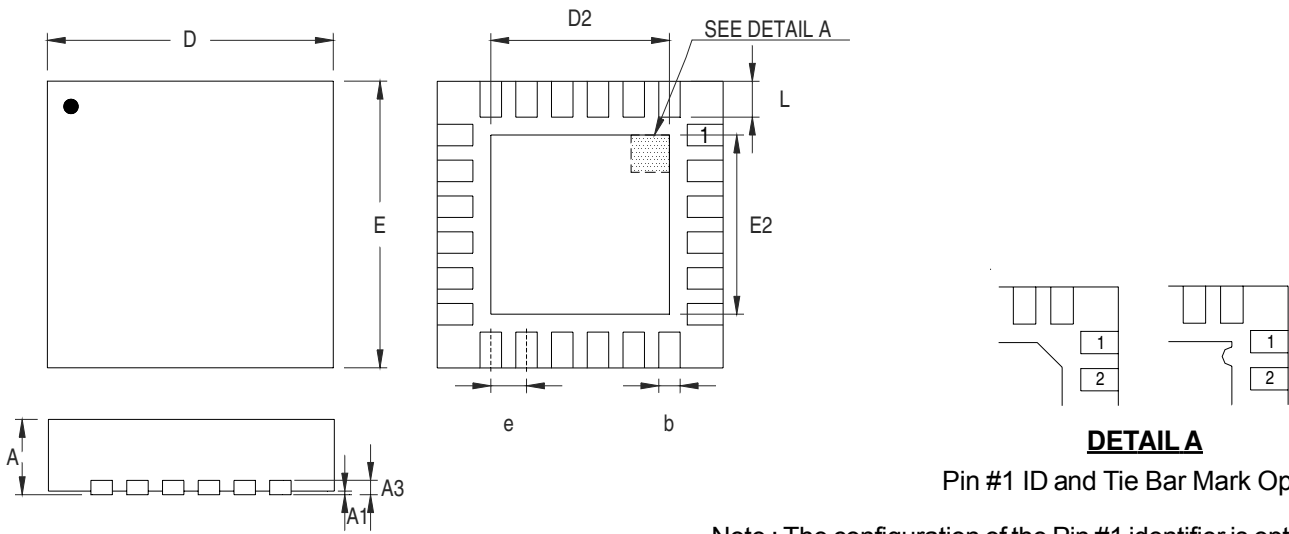

Figure 9. PCB Layout Guide

Outline Dimension



Pin #1 ID and Tie Bar Mark Options

Note : The configuration of the Pin #1 identifier is optional, but must be located within the zone indicated.

Symbol	Dimensions In Millimeters		Dimensions In Inches	
	Min	Max	Min	Max
A	0.700	0.800	0.028	0.031
A1	0.000	0.050	0.000	0.002
A3	0.175	0.250	0.007	0.010
b	0.180	0.300	0.007	0.012
D	3.950	4.050	0.156	0.159
D2	2.300	2.750	0.091	0.108
E	3.950	4.050	0.156	0.159
E2	2.300	2.750	0.091	0.108
e	0.500		0.020	
L	0.350	0.450	0.014	0.018

W-Type 24L QFN 4x4 Package

Richtek Technology Corporation

5F, No. 20, Taiyuen Street, Chupei City  
 Hsinchu, Taiwan, R.O.C.  
 Tel: (8863)5526789

Richtek products are sold by description only. Richtek reserves the right to change the circuitry and/or specifications without notice at any time. Customers should obtain the latest relevant information and data sheets before placing orders and should verify that such information is current and complete. Richtek cannot assume responsibility for use of any circuitry other than circuitry entirely embodied in a Richtek product. Information furnished by Richtek is believed to be accurate and reliable. However, no responsibility is assumed by Richtek or its subsidiaries for its use; nor for any infringements of patents or other rights of third parties which may result from its use. No license is granted by implication or otherwise under any patent or patent rights of Richtek or its subsidiaries.