



NOMINAL SIZE = 0.75 in x 0.5 in
(19,05 mm x 12,7 mm)

Features

- Up to 6-A Output Current
- 3.3 V Input Voltage
- Wide-Output Voltage Adjust (0.9 V to 2.5 V)
- Efficiencies up to 95 %
- 115 W/in³ Power Density
- On/Off Inhibit
- Under-Voltage Lockout
- Output Current Limit
- Over-Temperature Protection
- Operating Temp: -40 to +85 °C
- Surface Mount Package
- Safety Agency Approvals (Pending): UL 1950, CSA 22.2 950, EN60950 & VDE

Description

The PTH03000 series of non-isolated power modules are small in size and high on performance. Using double-sided surface mount construction and synchronous rectification technology, these regulators deliver up to 6 A of output current while occupying a PCB area of about half the size of a standard postage stamp. They are an ideal choice for applications where space, performance and cost are important design constraints.

The series operates from an input voltage of 3.3 V to provide step-down power conversion to any output voltage over the range, 0.9 V to 2.5 V. The output voltage of the PTH03000W is set within this range using a single resistor.

Operating features include an on/off inhibit, output voltage adjust (trim), an output current limit, and over-temperature protection.

Target applications include telecom, industrial, and general purpose circuits, including low-power dual-voltage systems that use a DSP, microprocessor, or ASIC.

Package options include both through-hole and surface mount configurations.

Pin Configuration

Pin	Function
1	GND
2	V _{in}
3	Inhibit*
4	V _o Adjust
5	V _{out}

* Denotes negative logic:
Open = Output On
Ground = Output Off

Standard Application

R_{set} = Required to set the output voltage to a value higher than 0.9 V (see spec. table for values)
C_{in} = Required 100 µF capacitor
C_{out} = Optional 100 µF capacitor

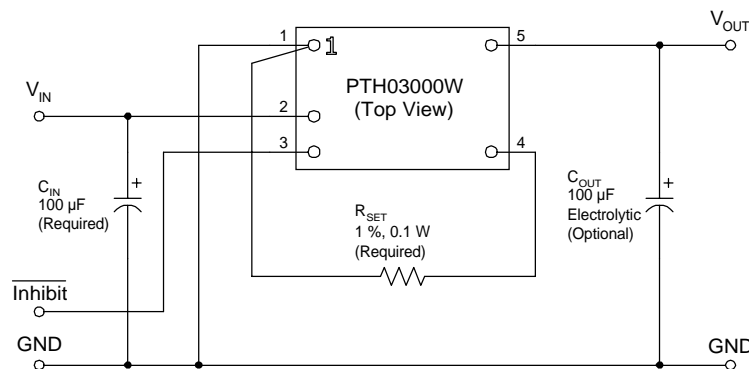

Ordering Information

Output Voltage (PTH03000□xx)		Package Options (PTH03000x□□) ⁽¹⁾		
Code	Voltage	Code	Description	Pkg Ref. ⁽²⁾
W	0.9 V – 2.5 V (Adjust)	AH	Horiz. T/H	(EUS)
		AS	SMD, Standard ⁽³⁾	(EUT)

Notes: (1) Add “T” to end of part number for tape and reel on SMD packages only.
 (2) Reference the applicable package reference drawing for the dimensions and PC board layout
 (3) “Standard” option specifies 63/37, Sn/Pb pin solder material.

Pin Descriptions

Vin: The positive input voltage power node to the module, which is referenced to common GND.

Vout: The regulated positive power output with respect to the GND node.

GND: This is the common ground connection for the ‘Vin’ and ‘Vout’ power connections. It is also the 0 VDC reference for the ‘Inhibit’ and ‘Vo Adjust’ control inputs.

Inhibit: The Inhibit pin is an open-collector/drain negative logic input that is referenced to GND. Applying a low-level ground signal to this input disables the module’s output and turns off the output voltage. When the Inhibit control is active, the input current drawn by the regulator is significantly reduced. If the Inhibit pin is left open-circuit, the module will produce an output whenever a valid input source is applied.

Vo Adjust: A 0.1 W 1 % resistor must be directly connected between this pin and the GND pin to set the output voltage to a value higher than 0.9 V. The temperature stability of the resistor should be 100 ppm/°C (or better). The set point range for the output voltage is from 0.9 V to 2.5 V. The resistor required for a given output voltage may be calculated from the following formula. If left open circuit, the output voltage will default to its lowest value. For further information on output voltage adjustment, consult the related application note.

$$R_{set} = 10 \text{ k}\Omega \cdot \frac{0.891 \text{ V}}{V_{out} - 0.9 \text{ V}} - 4.99 \text{ k}\Omega$$

The specification table gives the preferred resistor values for a number of standard output voltages.

Environmental & Absolute Maximum Ratings

Characteristics	Symbols	Conditions	Min	Typ	Max	Units
Operating Temperature Range	T_a	Over V_{in} Range	-40 (i)	—	+85	°C
Solder Reflow Temperature	T_{reflow}	Surface temperature of module body or pins	—	—	235 (ii)	°C
Storage Temperature	T_s	—	-40	—	+125	°C
Over Temperature Protection	OTP	IC junction temperature	—	150	—	°C
Mechanical Shock	—	Per Mil-STD-883D, Method 2002.3 1 msec, ½ sine, mounted	—	500	—	G's
Mechanical Vibration	—	Mil-STD-883D, Method 2007.2 20-2000 Hz	—	20	—	G's
Weight	—	—	—	2	—	grams
Flammability	—	Meets UL 94V-O	—	—	—	—

Notes: (i) During reflow of SMD package version do not elevate peak temperature of the module, pins or internal components above the stated maximum.

Electrical Specifications Unless otherwise stated, $T_a = 25$ °C, $V_{in} = 3.3$ V, $V_o = 2$ V, $C_{in} = 100$ µF, $C_{out} = 0$ µF, and $I_o = I_{o,max}$

Characteristics	Symbols	Conditions	PTH03000W			Units
			Min	Typ	Max	
Output Current	I_o	$0.9\text{ V} \leq V_o \leq 2.5\text{ V}$, $T_a = 60$ °C, 200 LFM airflow $T_a = 25$ °C, natural convection	0 0	— —	6 (1) 6 (1)	A
Input Voltage Range	V_{in}	Over I_o range	3	—	3.6	V
Set-Point Voltage Tolerance	$V_o\text{tol}$	—	—	—	±2 (2)	% V_o
Temperature Variation	ΔReg_{temp}	-40 °C < T_a < +85 °C	—	±0.5	—	% V_o
Line Regulation	ΔReg_{line}	Over V_{in} range	—	±5	—	mV
Load Regulation	ΔReg_{load}	Over I_o range	—	±5	—	mV
Total Output Variation	ΔReg_{tot}	Includes set-point, line, load, -40 °C ≤ T_a ≤ +85 °C	—	—	±3 (2)	% V_o
Efficiency	η	$I_o = 4\text{ A}$ $R_{SET} = 576\ \Omega$ $V_o = 2.5\text{ V}$ $R_{SET} = 3.09\text{ k}\Omega$ $V_o = 2.0\text{ V}$ $R_{SET} = 4.87\text{ k}\Omega$ $V_o = 1.8\text{ V}$ $R_{SET} = 9.76\text{ k}\Omega$ $V_o = 1.5\text{ V}$ $R_{SET} = 24.3\text{ k}\Omega$ $V_o = 1.2\text{ V}$ $R_{SET} = 82.5\text{ k}\Omega$ $V_o = 1.0\text{ V}$	— — — — — —	93 91 90 88 86 84	— — — — — —	%
V_o Ripple (pk-pk)	V_r	20 MHz bandwidth	—	20	—	mVpp
Transient Response	t_{tr} ΔV_{tr}	1 A/µs load step, 50 to 100 % $I_{o,max}$, $V_o = 1.8\text{ V}$, $C_{out} = 100\ \mu\text{F}$ Recovery time V_o over/undershoot	— —	70 100	— —	µSec mV
Current Limit	I_{lim}	$\Delta V_o = -50\text{ mV}$	—	13	—	A
Under-Voltage Lockout	UVLO	V_{in} increasing V_{in} decreasing	— 2.6	2.95 2.8	3 —	V
Inhibit Control (pin 3) Input High Voltage Input Low Voltage Input Low Current	V_{IH} V_{IL} I_{IL}	Referenced to GND Pin 3 to GND	$V_{in} - 0.5$ -0.2 —	— — -10	Open (3) 0.8 —	V V µA
Standby Input Current	$I_{in\ inh}$	pins 1 & 3 connected	—	1	—	mA
Switching Frequency	f_s	Over V_{in} and I_o ranges	—	700	—	kHz
External Input Capacitance	C_{in}	—	100 (4)	—	—	µF
External Output Capacitance	C_{out}	Capacitance value non-ceramic ceramic Equiv. series resistance (non-ceramic)	0 0 4 (7)	100 (5) — —	1,000 (6) 300 —	µF µF mΩ
Reliability	MTBF	Per Bellcore TR-332 50 % stress, $T_a = 40$ °C, ground benign	28	—	—	10 ⁶ Hrs

- Notes: (1) See SOA curves or consult factory for appropriate derating.
 (2) The set-point voltage tolerance is affected by the tolerance and stability of R_{SET} . The stated limit is unconditionally met if R_{SET} has a tolerance of 1 % with 100 ppm/°C or better temperature stability.
 (3) The Inhibit control (pin 3) has an internal pull-up to V_{in} , and if left open-circuit the module will operate when input power is applied. A small low-leakage (<100 nA) MOSFET is recommended to control this input. See application notes for more information.
 (4) The regulator requires a minimum of 100 µF input capacitor with a minimum 300 mA rms ripple current rating. For further information, consult the related application note on Capacitor Recommendations.
 (5) An external output capacitor is not required for basic operation. Adding 100 µF of distributed capacitance at the load will improve the transient response.
 (6) This is the calculated maximum. The minimum ESR limitation will often result in a lower value. Consult the application notes for further guidance.
 (7) This is the typical ESR for all the electrolytic (non-ceramic) output capacitance. Use 7 mΩ as the minimum when using max-ESR values to calculate.

Characteristic Data; $V_{in} = 3.3V$ (See Note A)

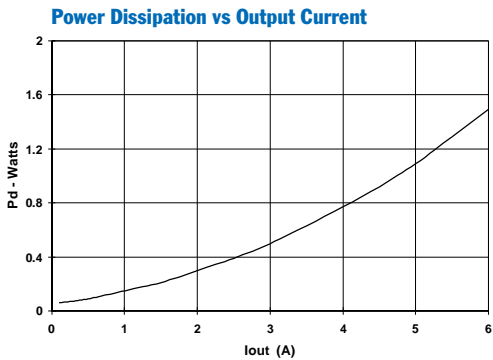
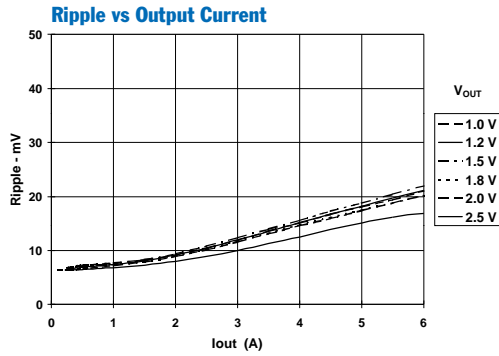
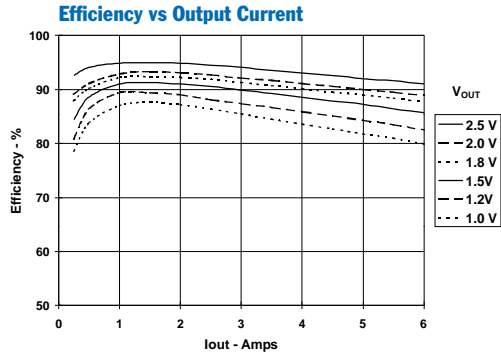

Safe Operating Area; $V_{in} = 3.3V$ (See Note B)

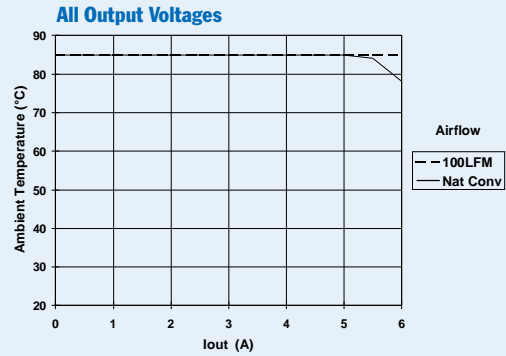

Note A: Characteristic data has been developed from actual products tested at 25°C. This data is considered typical data for the Converter.

Note B: SOA curves represent the conditions at which internal components are at or below the manufacturer's maximum operating temperatures. Derating limits apply to modules soldered directly to a 4 in. × 4 in. double-sided PCB with 1 oz. copper.

Capacitor Recommendations for the PTH03000W, Wide-Output Adjust Power Modules

Input Capacitor

The recommended input capacitor(s) is determined by the 100 μF minimum capacitance and 300 mArms minimum ripple current rating.

Ripple current, less than 300 m Ω equivalent series resistance (ESR), and temperature are the major considerations when selecting input capacitors. Unlike polymer tantalum, regular tantalum capacitors have a recommended minimum voltage rating of $2 \times$ (maximum DC voltage + AC ripple). This is standard practice to ensure reliability.

For improved ripple reduction on the input bus, ceramic capacitors [2] may be used to complement electrolytic types and achieve the minimum required capacitance.

Output Capacitors (Optional)

For applications with load transients (sudden changes in load current), regulator response will benefit from an external output capacitance. The recommended output capacitance of 100 μF will allow the module to meet its transient response specification (see product data sheet). For most applications, a high quality computer-grade aluminum electrolytic capacitor is adequate. These capacitors provide decoupling over the frequency range, 2 kHz to 150 kHz, and are suitable for ambient temperatures above 0 $^{\circ}\text{C}$. For operation below 0 $^{\circ}\text{C}$ tantalum, ceramic or Os-Con type capacitors are recommended. When using one or more non-ceramic capacitors, the calculated equivalent ESR should be no lower than 4 m Ω (7 m Ω using the manufacturer's maximum ESR for a single capacitor). A list of preferred low-ESR type capacitors are identified in Table 1-1.

Ceramic Capacitors

Above 150 kHz the performance of aluminum electrolytic capacitors becomes less effective. To further improve the reflected input ripple current [2] or the output transient response, multilayer ceramic capacitors can also be added. Ceramic capacitors have very low ESR and their resonant frequency is higher than the bandwidth of the regulator. When used on the output their combined ESR is not critical as long as the total value of ceramic capacitance does not exceed 300 μF . Also, to prevent the formation of local resonances, do not place more than five identical ceramic capacitors in parallel with values of 10 μF or greater.

Tantalum Capacitors

Tantalum type capacitors can be used at both the input and output, and are recommended for applications where the ambient operating temperature can be less than 0 $^{\circ}\text{C}$. The AVX TPS, Sprague 593D/594/595 and Kemet T495/

T510 capacitor series are suggested over many other tantalum types due to their higher rated surge, power dissipation, and ripple current capability. As a caution many general purpose tantalum capacitors have considerably higher ESR, reduced power dissipation and lower ripple current capability. These capacitors are also less reliable as they have lower power dissipation and surge current ratings. Tantalum capacitors that do not have a stated ESR or surge current rating are not recommended for power applications.

When specifying Os-Con and polymer tantalum capacitors for the output, the minimum ESR limit will be encountered well before the maximum capacitance value is reached.

Capacitor Table

Table 1-1 identifies the characteristics of capacitors from a number of vendors with acceptable ESR and ripple current (rms) ratings. The recommended number of capacitors required at both the input and output buses is identified for each capacitor type.

This is not an extensive capacitor list. Capacitors from other vendors are available with comparable specifications. Those listed are for guidance. The RMS ripple current rating and ESR (at 100 kHz) are critical parameters necessary to insure both optimum regulator performance and long capacitor life.

Designing for Very Fast Load Transients

The transient response of the DC/DC converter has been characterized using a load transient with a di/dt of 1 A/ μs . The typical voltage deviation for this load transient is given in the data sheet specification table using the optional value of output capacitance. As the di/dt of a transient is increased, the response of a converter's regulation circuit ultimately depends on its output capacitor decoupling network. This is an inherent limitation with any DC/DC converter once the speed of the transient exceeds its bandwidth capability. If the target application specifies a higher di/dt or lower voltage deviation, the requirement can only be met with additional output capacitor decoupling. In these cases special attention must be paid to the type, value and ESR of the capacitors selected.

If the transient performance requirements exceed that specified in the data sheet, the selection of output capacitors becomes more important. For further guidance consult the separate application note, "Selecting Output Capacitors for PTH Products in High-Performance Applications."

Table 1-1: Input/Output Capacitors

Capacitor Vendor, Type/ Series (Style)	Capacitor Characteristics					Quantity		Vendor Number
	Working Voltage	Value (µF)	Max. (ESR) at 100 kHz	Max. Ripple at 85 °C Current (Irms)	Physical Size (mm)	Input Bus	Output Bus	
Panasonic FC, Aluminum (SMD) WA, Poly-Aluminum (SMD)	25 V 10 V	100 µF 120 µF	0.300 Ω 0.035 Ω	450 mA 2800 mA	8×10 8.3×6.9	1 1	1 ≤3	EEVFC1E101P EEFWA1A121P
Panasonic, Aluminum FC (Radial) FK (SMD)	16 V 16 V	220 µF 330 µF	0.150 Ω 0.160 Ω	555 mA 600 mA	10×10.2 8×10.2	1 1	≤5 ≤3	EEUFC1C221 EEVFK1C331P
United Chemi-Con FS, Os-con (Radial) PXA, Poly-Alum (SMD) MVZ, Aluminum (SMD) PS, Poly-Alum. (Radial)	10 V 10 V 16 V 10 V	100 µF 120 µF 220 µF 100 µF	0.040 Ω 0.027 Ω 0.170 Ω 0.024 Ω	2100 mA 2430 mA 450 mA 4420 mA	6.3×9.8 8×6.7 8×10 8×11.5	1 1 1 1	≤3 ≤3 ≤5 ≤3	10FS100M PXA10VC121MH80TP MVZ25VC221MH10TP 10PS270MH11
Nichicon, Aluminum WG, Aluminum (SMD) PM, (Radial) F55, Tantalum (SMD)	35 V 25 V 10 V	100 µF 150 µF 100 µF	0.150 Ω 0.160 Ω 0.055 Ω	670 mA 460 mA 2000 mA	10×10 10×11.5 7.7×4.3	1 1 1	1 ≤5 ≤3	UWG1V101MNR1GS UPM1E151MPH F551A107MN
Sanyo SVP, Os-con (SMD) SP, Os-con (Radial) TPE, Poscap Polymer (SMD)	10 V 16 V 10 V	120 µF 100 µF 220 µF	0.040 Ω 0.025 Ω 0.025 Ω	>2500 mA >2800 mA >2400mA	7×8 6.3×9.8 7.3×5.7	1 1 1	≤3 ≤2 ≤2	10SVP120M 16SPS100M 10TPE220ML
AVX, Tantalum TPS (SMD)	10 V 10 V	100 µF 220 µF	0.100 Ω 0.100 Ω	>1090 mA >1414 mA	7.3L ×4.3W ×4.1H	1 1	≤3 ≤3	TPSD107M010R0100 TPSV227M010R0100
Kemet T520, Poly-Alum (SMD) T495, Tantalum (SMD) A700-Poly-Alum. (SMD)	10 V 10 V 6.3 V	100 µF 100 µF 100 µF	0.080 Ω 0.100 Ω 0.018 Ω	1200 mA >1100 mA 2900 mA	7.3L ×5.7W ×4.0H	1 1 1	≤4 ≤4 ≤2	T520D107M010AS T495X107M010AS A700D107M006AT
Vishay-Sprague 594D, Tantalum (SMD) 595D, Tantalum (SMD) 94SA, Os-con (Radial)	10 V 10 V 10 V	150 µF 120 µF 100 µF	0.090 Ω 0.140 Ω 0.030 Ω	1100 mA >1000 mA 2670 mA	7.3L ×6.0W ×4.1H 8×10.5	1 1 1	≤4 ≤4 ≤2	594D157X0010C2T 595D127X0010D2T 94SA107X0010EBP
Kemet, Ceramic X5R (SMD)	16 V 6.3 V	10 47	0.002 Ω 0.002 Ω	—	1210 case 3225 mm	1 2 [1]	≤5 ≤2	C1210C106M4PAC C1210C476K9PAC
Murata, Ceramic X5R (SMD)	6.3 V 6.3 V 16 V 16 V	100 47 22 10	0.002 Ω	—	1210 case 3225 mm	1 2 [1] 5 1 [2]	≤1 ≤2 ≤3 ≤5	GRM32ER60J107M GRM32ER60J476M GRM32ER61C226K GRM32DR61C106K
TDK, Ceramic X5R (SMD)	6.3 V 6.3 V 16 V 16 V	100 47 22 10	0.002 Ω	—	1210 case 3225 mm	1 2 [1] 5 1 [2]	≤1 ≤2 ≤3 ≤5	C3225X5R0J107MT C3225X5R0J476MT C3225X5R1C226MT C3225X5R1C106MT

[1] A total capacitance of 94 µF is acceptable based on the combined ripple current rating.

[2] A ceramic capacitor may be used to complement electrolytic types at the input to further reduce high-frequency ripple current.

Adjusting the Output Voltage of the PTH03000W Wide-Output Adjust Power Modules

The $V_o Adjust$ control (pin 4) sets the output voltage of the PTH03000W product. The adjustment range is from 0.9 V to 2.5 V. The adjustment method requires the addition of a single external resistor, R_{set} , that must be connected directly between the $V_o Adjust$ and GND pins 1. Table 2-1 gives the preferred value of the external resistor for a number of standard voltages, along with the actual output voltage that this resistance value provides.

For other output voltages the value of the required resistor can either be calculated using the following formula, or simply selected from the range of values given in Table 2-2. Figure 2-1 shows the placement of the required resistor.

$$R_{set} = 10 \text{ k}\Omega \cdot \frac{0.891 \text{ V}}{V_{out} - 0.9 \text{ V}} - 4.99 \text{ k}\Omega$$

Table 2-1; Preferred Values of R_{set} for Standard Output Voltages

V_{out} (Standard)	R_{set} (Pref'd Value)	V_{out} (Actual)
2.5 V	576 Ω	2.501V
2 V	3.09 k Ω	2.003 V
1.8 V	4.87 k Ω	1.804 V
1.5 V	9.76 k Ω	1.504 V
1.2 V	24.3 k Ω	1.204 V
1 V	82.5 k Ω	1.002 V
0.9 V	Open	0.9 V

Figure 2-1; $V_o Adjust$ Resistor Placement

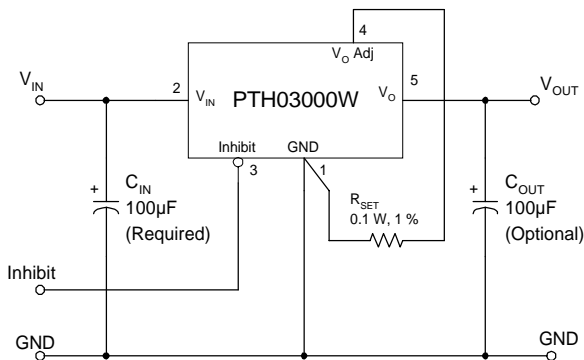

Table 2-2; Output Voltage Set-Point Resistor Values

V_a Req'd	R_{set}	V_a Req'd	R_{set}
0.900	Open	1.50	9.86 k Ω
0.925	351 k Ω	1.55	8.72 k Ω
0.950	173 k Ω	1.60	7.74 k Ω
0.975	114 k Ω	1.65	6.89 k Ω
1.000	84.1 k Ω	1.70	6.15 k Ω
1.025	66.3 k Ω	1.75	5.49 k Ω
1.050	54.4 k Ω	1.80	4.91 k Ω
1.075	45.9 k Ω	1.85	4.39 k Ω
1.100	39.6 k Ω	1.90	3.92 k Ω
1.125	34.6 k Ω	1.95	3.50 k Ω
1.150	30.7 k Ω	2.00	3.11 k Ω
1.175	27.4 k Ω	2.05	2.76 k Ω
1.200	24.7 k Ω	2.10	2.44 k Ω
1.225	22.4 k Ω	2.15	2.14 k Ω
1.250	20.5 k Ω	2.20	1.86 k Ω
1.275	18.8 k Ω	2.25	1.61 k Ω
1.300	17.3 k Ω	2.30	1.37 k Ω
1.325	16.0 k Ω	2.35	1.15 k Ω
1.350	14.8 k Ω	2.40	950 Ω
1.375	13.8 k Ω	2.45	758 Ω
1.400	12.8 k Ω	2.50	579 Ω
1.425	12.0 k Ω		
1.450	11.2 k Ω		
1.475	10.5 k Ω		

Notes:

1. Use a 0.1 W resistor. The tolerance should be 1 %, with a temperature stability of 100 ppm/ $^{\circ}\text{C}$ (or better). Place the resistor as close to the regulator as possible. Connect the resistor directly between pins 4 and 1 using dedicated PCB traces.
2. Never connect capacitors from $V_o Adjust$ to either GND or V_{out} . Any capacitance added to the $V_o Adjust$ pin will affect the stability of the regulator.

Power-Up Characteristics

When configured per their standard application, the PTH03000 and PTH05000 series of power modules will produce a regulated output voltage following the application of a valid input source voltage. During power up, internal soft-start circuitry slows the rate that the output voltage rises, thereby limiting the amount of in-rush current that can be drawn from the input source. The soft-start circuitry introduces a short time delay (typically 10 ms) into the power-up characteristic. This is from the point that a valid input source is recognized. Figure 3-1 shows the power-up waveforms for a PTH05000W (5-V input), with the output voltage set point adjusted for a 2-V output. The waveforms were measured with a 5-A resistive load. The initial rise in input current when the input voltage first starts to rise is the charge current drawn by the input capacitors.

Figure 3-1

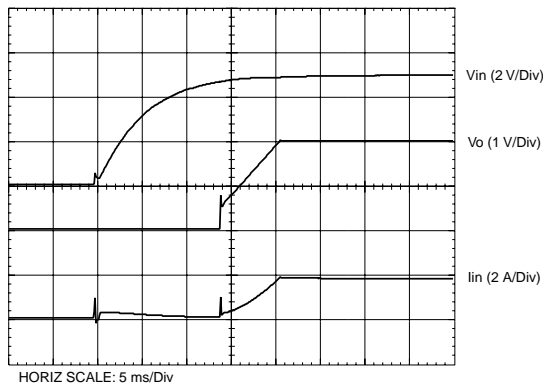

Current Limit Protection

The PTHxx000W modules protect against load faults with a continuous current limit characteristic. Under a load fault condition the output current cannot exceed the current limit value. Attempting to draw current that exceeds the current limit value causes the output voltage to be progressively reduced. Current is continuously supplied to the fault until it is removed. Upon removal of the fault, the output voltage will promptly recover.

Thermal Shutdown

Thermal shutdown protects the module's internal circuitry against excessively high temperatures. A rise in temperature may be the result of a drop in airflow, a high ambient temperature, or a sustained current limit condition. If the junction temperature of the internal components exceed 150 °C, the module will shutdown. This reduces the output voltage to zero. The module will start up automatically, by initiating a soft-start power up when the sensed temperature decreases 10 °C below the thermal shutdown trip point.

Output On/Off Inhibit

For applications requiring output voltage on/off control, the PTH03000W & PTH05000W power modules incorporate an output on/off *Inhibit* control (pin 3). The inhibit feature can be used wherever there is a requirement for the output voltage from the regulator to be turned off.

The power module functions normally when the *Inhibit* pin is left open-circuit, providing a regulated output whenever a valid source voltage is connected to V_{in} with respect to GND .

Figure 3-2 shows the typical application of the inhibit function. Note the discrete transistor (Q_1). The *Inhibit* control has its own internal pull-up to V_{in} potential. An open-collector or open-drain device is recommended to control this input.

Turning Q_1 on applies a low voltage to the *Inhibit* control pin and disables the output of the module. If Q_1 is then turned off, the module will execute a soft-start power-up sequence. A regulated output voltage is produced within 20 msec. Figure 3-3 shows the typical rise in the output voltage, following the turn-off of Q_1 . The turn off of Q_1 corresponds to the fall in the waveform, $Q_1 V_{gs}$. The waveforms were measured with a 5-A resistive load.

Figure 3-2

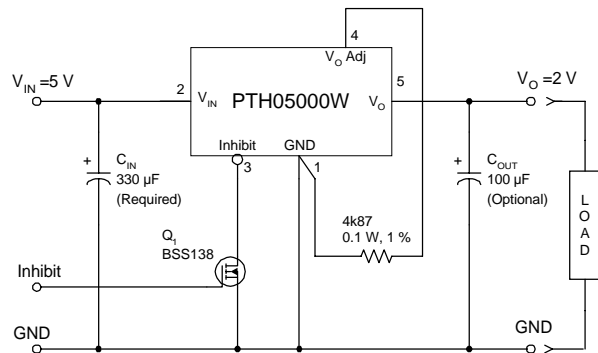
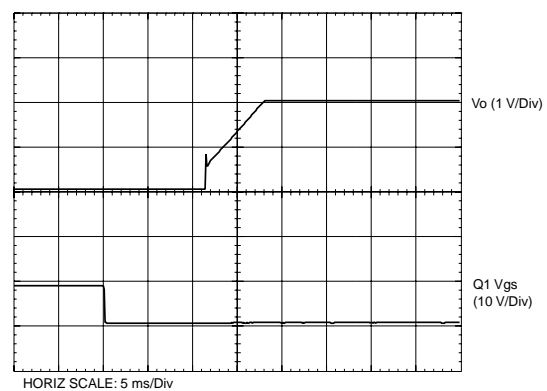

Figure 3-3



PACKAGING INFORMATION

Orderable Device	Status (1)	Package Type	Package Drawing	Pins	Package Qty	Eco Plan (2)	Lead/Ball Finish (6)	MSL Peak Temp (3)	Op Temp (°C)	Device Marking (4/5)	Samples
PTH03000WAD	ACTIVE	Through-Hole Module	EUS	5	56	RoHS (In Work) & Green (In Work)	SN	N / A for Pkg Type			Samples
PTH03000WAH	ACTIVE	Through-Hole Module	EUS	5	56	RoHS (In Work) & Green (In Work)	SN	N / A for Pkg Type	-40 to 85		Samples
PTH03000WAS	ACTIVE	Surface Mount Module	EUT	5	49	Non-RoHS & Green (In Work)	SNPB	Level-1-235C-UNLIM/ Level-3-260C-168HRS	-40 to 85		Samples
PTH03000WAST	ACTIVE	Surface Mount Module	EUT	5	250	Non-RoHS & Green (In Work)	SNPB	Level-1-235C-UNLIM/ Level-3-260C-168HRS			Samples
PTH03000WAZ	ACTIVE	Surface Mount Module	EUT	5	49	RoHS (In Work) & Green (In Work)	SNAGCU	Level-3-260C-168 HR	-40 to 85		Samples
PTH03000WAZT	ACTIVE	Surface Mount Module	EUT	5	250	RoHS (In Work) & Green (In Work)	SNAGCU	Level-3-260C-168 HR	-40 to 85		Samples

(1) The marketing status values are defined as follows:

ACTIVE: Product device recommended for new designs.

LIFEBUY: TI has announced that the device will be discontinued, and a lifetime-buy period is in effect.

NRND: Not recommended for new designs. Device is in production to support existing customers, but TI does not recommend using this part in a new design.

PREVIEW: Device has been announced but is not in production. Samples may or may not be available.

OBSOLETE: TI has discontinued the production of the device.

(2) **RoHS:** TI defines "RoHS" to mean semiconductor products that are compliant with the current EU RoHS requirements for all 10 RoHS substances, including the requirement that RoHS substance do not exceed 0.1% by weight in homogeneous materials. Where designed to be soldered at high temperatures, "RoHS" products are suitable for use in specified lead-free processes. TI may reference these types of products as "Pb-Free".

RoHS Exempt: TI defines "RoHS Exempt" to mean products that contain lead but are compliant with EU RoHS pursuant to a specific EU RoHS exemption.

Green: TI defines "Green" to mean the content of Chlorine (Cl) and Bromine (Br) based flame retardants meet JS709B low halogen requirements of <=1000ppm threshold. Antimony trioxide based flame retardants must also meet the <=1000ppm threshold requirement.

(3) MSL, Peak Temp. - The Moisture Sensitivity Level rating according to the JEDEC industry standard classifications, and peak solder temperature.

(4) There may be additional marking, which relates to the logo, the lot trace code information, or the environmental category on the device.

⁽⁵⁾ Multiple Device Markings will be inside parentheses. Only one Device Marking contained in parentheses and separated by a "~" will appear on a device. If a line is indented then it is a continuation of the previous line and the two combined represent the entire Device Marking for that device.

⁽⁶⁾ Lead/Ball Finish - Orderable Devices may have multiple material finish options. Finish options are separated by a vertical ruled line. Lead/Ball Finish values may wrap to two lines if the finish value exceeds the maximum column width.

Important Information and Disclaimer:The information provided on this page represents TI's knowledge and belief as of the date that it is provided. TI bases its knowledge and belief on information provided by third parties, and makes no representation or warranty as to the accuracy of such information. Efforts are underway to better integrate information from third parties. TI has taken and continues to take reasonable steps to provide representative and accurate information but may not have conducted destructive testing or chemical analysis on incoming materials and chemicals. TI and TI suppliers consider certain information to be proprietary, and thus CAS numbers and other limited information may not be available for release.

In no event shall TI's liability arising out of such information exceed the total purchase price of the TI part(s) at issue in this document sold by TI to Customer on an annual basis.

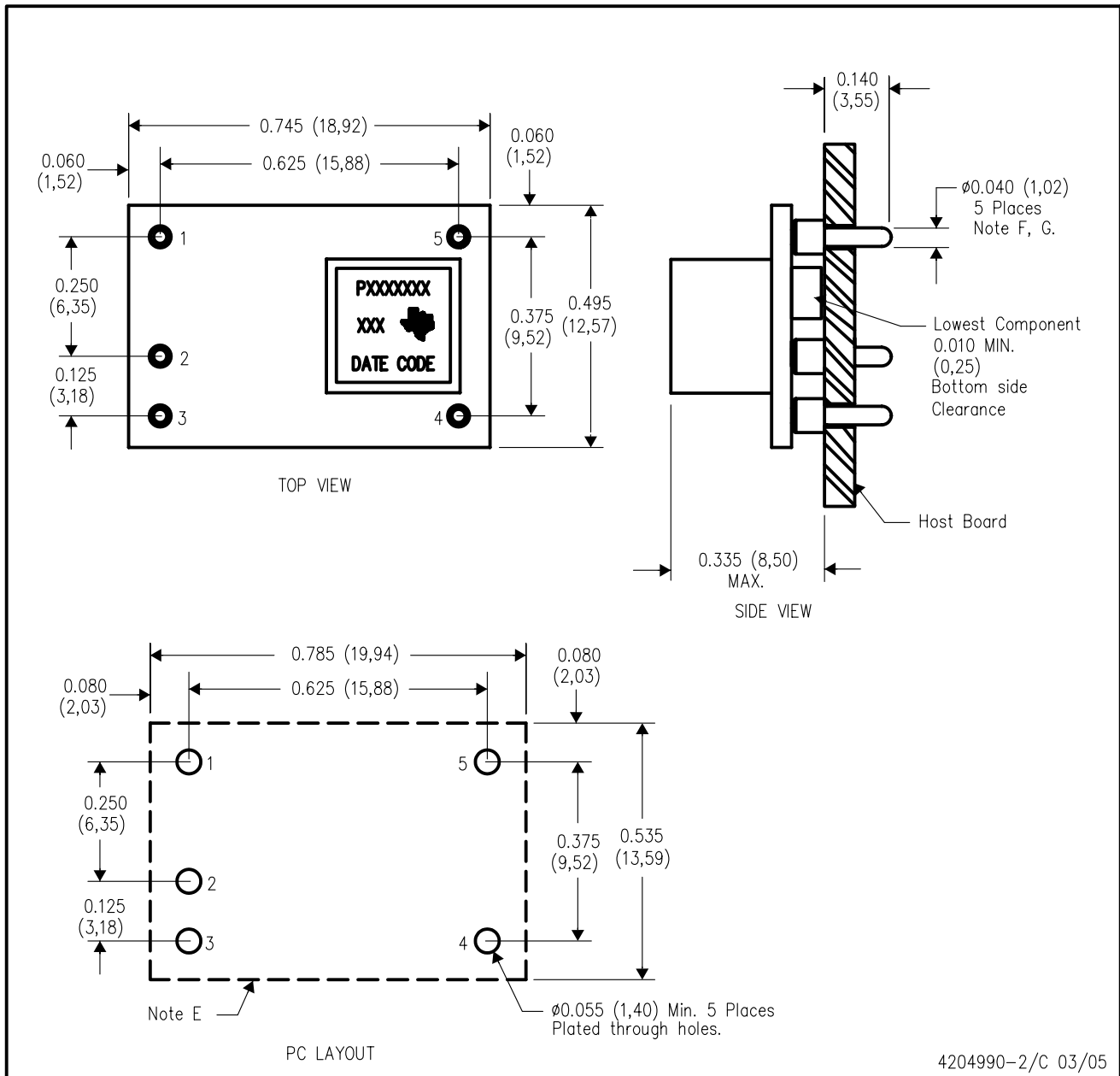

4204990-2/C 03/05

- NOTES:
- A. All linear dimensions are in inches (mm).
 - B. This drawing is subject to change without notice.
 - C. 2 place decimals are ± 0.030 ($\pm 0,76\text{mm}$).
 - D. 3 place decimals are ± 0.010 ($\pm 0,25\text{mm}$).
 - E. Recommended keep out area for user components.
 - F. Pins are 0.040" (1,02) diameter with 0.070" (1,78) diameter standoff shoulder.
 - G. All pins: Material - Copper Alloy
Finish - Tin (100%) over Nickel plate

IMPORTANT NOTICE AND DISCLAIMER

TI PROVIDES TECHNICAL AND RELIABILITY DATA (INCLUDING DATASHEETS), DESIGN RESOURCES (INCLUDING REFERENCE DESIGNS), APPLICATION OR OTHER DESIGN ADVICE, WEB TOOLS, SAFETY INFORMATION, AND OTHER RESOURCES "AS IS" AND WITH ALL FAULTS, AND DISCLAIMS ALL WARRANTIES, EXPRESS AND IMPLIED, INCLUDING WITHOUT LIMITATION ANY IMPLIED WARRANTIES OF MERCHANTABILITY, FITNESS FOR A PARTICULAR PURPOSE OR NON-INFRINGEMENT OF THIRD PARTY INTELLECTUAL PROPERTY RIGHTS.

These resources are intended for skilled developers designing with TI products. You are solely responsible for (1) selecting the appropriate TI products for your application, (2) designing, validating and testing your application, and (3) ensuring your application meets applicable standards, and any other safety, security, or other requirements. These resources are subject to change without notice. TI grants you permission to use these resources only for development of an application that uses the TI products described in the resource. Other reproduction and display of these resources is prohibited. No license is granted to any other TI intellectual property right or to any third party intellectual property right. TI disclaims responsibility for, and you will fully indemnify TI and its representatives against, any claims, damages, costs, losses, and liabilities arising out of your use of these resources.

TI's products are provided subject to TI's Terms of Sale (www.ti.com/legal/termsofsale.html) or other applicable terms available either on ti.com or provided in conjunction with such TI products. TI's provision of these resources does not expand or otherwise alter TI's applicable warranties or warranty disclaimers for TI products.

Mailing Address: Texas Instruments, Post Office Box 655303, Dallas, Texas 75265
Copyright © 2019, Texas Instruments Incorporated