

REVISIONS					
P	LTR	DESCRIPTION	DATE	DMN	APVD
G		REVISED PER ECR-20-000808	26MAY2020	PC	SW

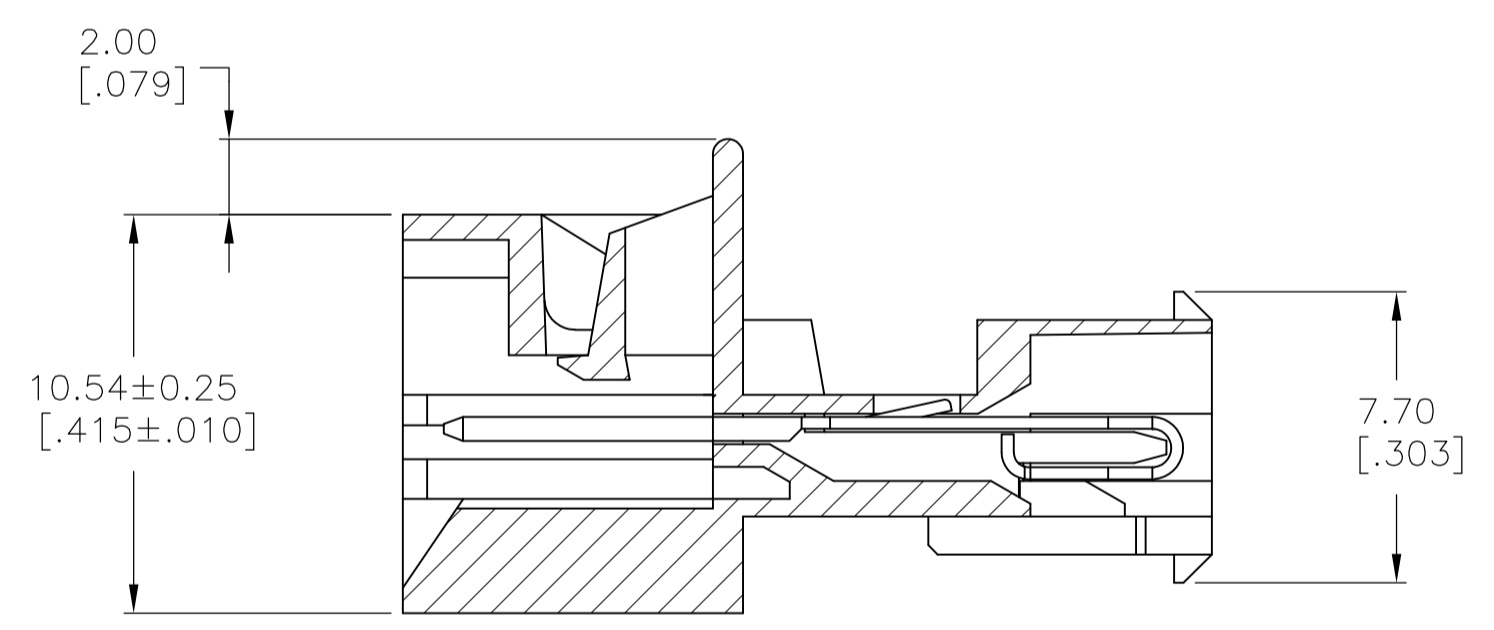

SECTION A-A

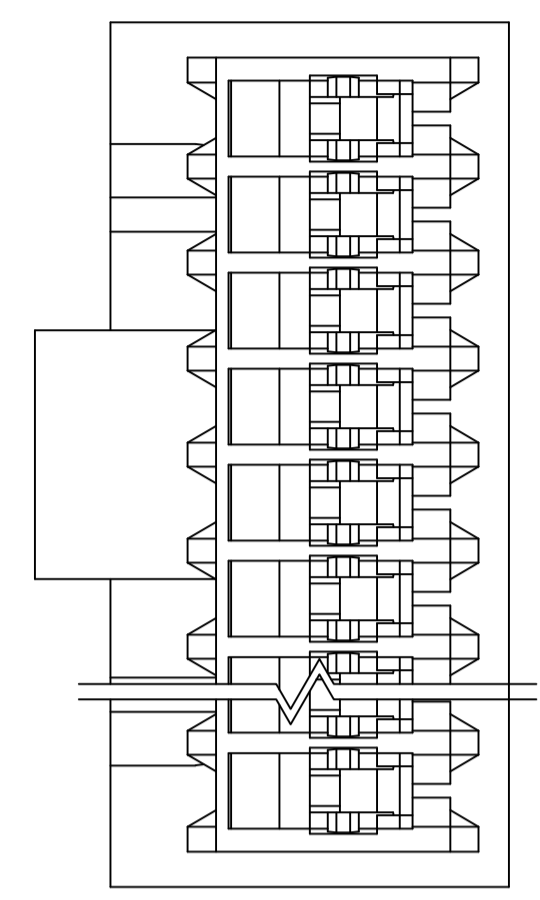
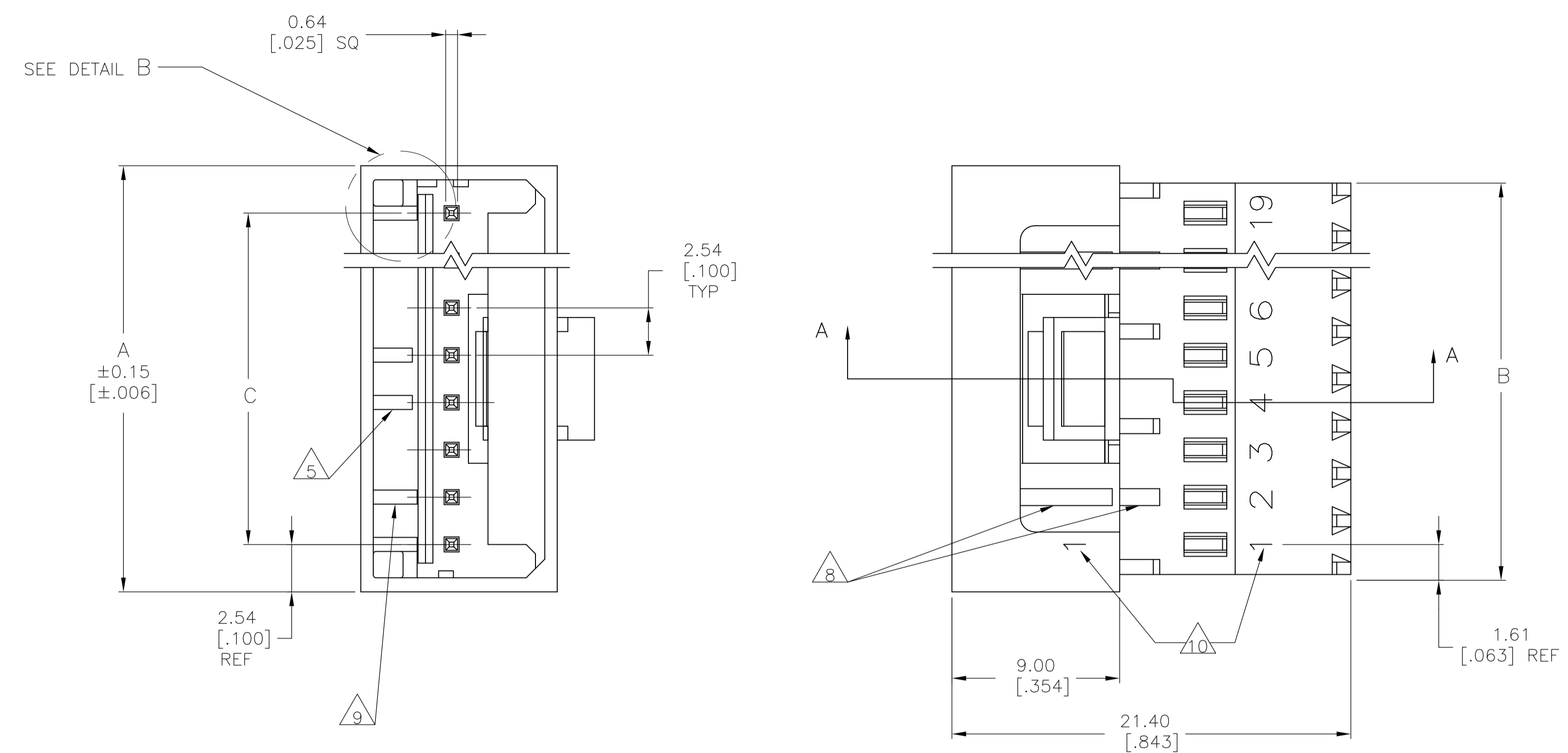
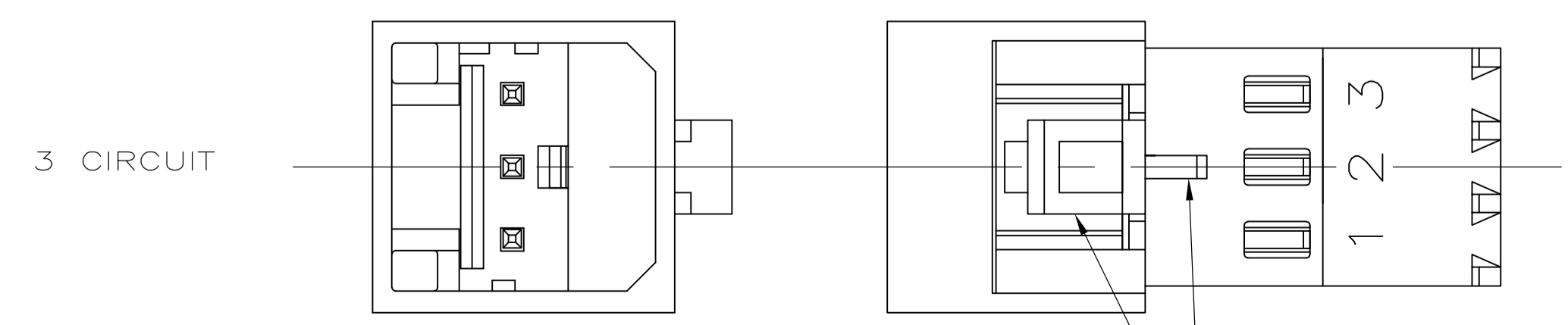
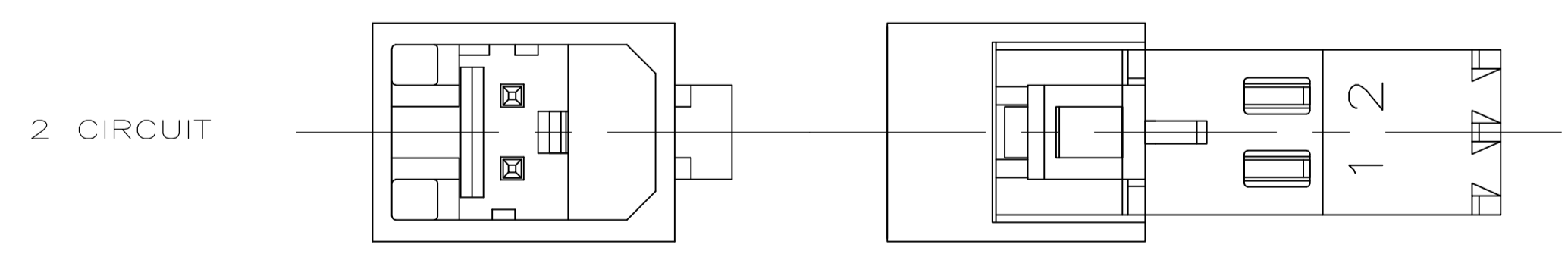

DETAIL A 3

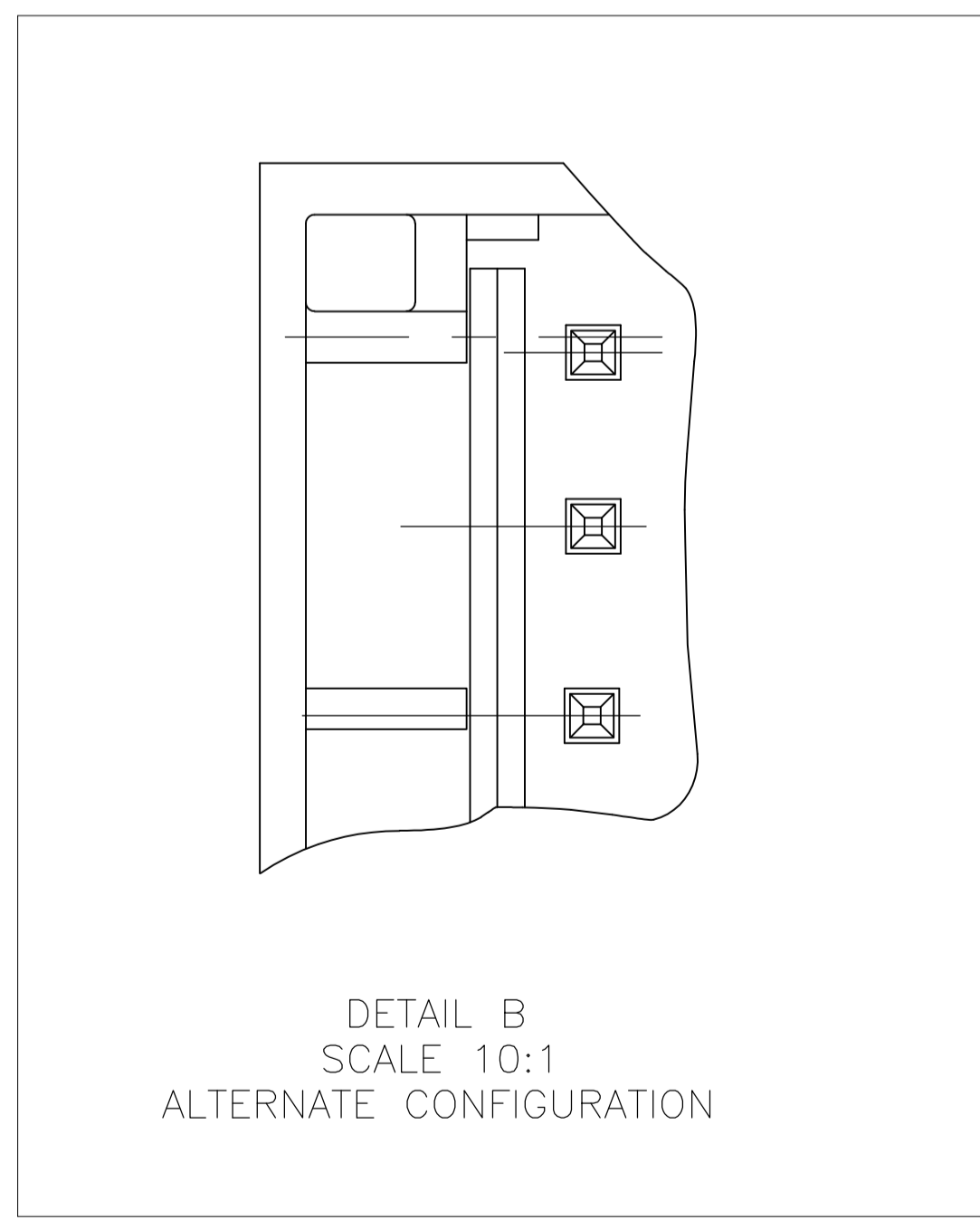

- 1 MATERIAL:
 HOUSING- NYLON UL94V-2 (BLUE).
 CONTACTS- 0.30 [.012] THK COPPER ALLOY
 DUAL PLATING : GOLD PLATE AREA, 0.00076 [.000030] GOLD OR 0.00008 [.000003] MIN GOLD FLASH OVER 0.00068 [.000027] PALLADIUM NICKEL, PER TE CONNECTIVITY'S DISCRETION, ALL SIDES, OVER NICKEL UNDERPLATE, .00127 [.000050] MIN, ALL SIDES AND ENTIRE LENGTH OF POST.
 ONPOST, BRIGHT TIN-LEAD 0.00203[.000080] MIN THK 647010-2 THRU 1-647010-9 OR MATTE TIN 0.00203[.000080] MIN THK. FOR 3-647016-2 THRU 4-647010-9 ON WIRE SLOT, WITH NICKEL UNDERPLATE .00127[.000050] MIN THK ALL OVER.
- 2 CONTACTS ACCEPT 26 AWG (0.12 - 0.15 mm mm²) TIN PLATED SOLID, CONCENTRIC FUSED STRANDED, OR CONCENTRIC STRANDED (7 STRANDS) WIRE WITH 1.52 [.060] MAX INSULATION DIAMETER.
- 3 MATES WITH STANDARD MTA-100 CONNECTORS:
 OF THE SAME CIRCUIT SIZES
 WITH SIMILARLY PLATED CONTACTS
 WITH POLARIZING TABS-CIRCUIT SIZES 4-19 ONLY
 WITHOUT POLARIZING TABS-CIRCUIT SIZES 2 & 3.

 DOES NOT MATE WITH MTA-100 CONNECTORS:
 WITH POLARIZING TABS-CIRCUIT SIZES 2 & 3 ONLY.
 (SEE DETAIL A)
 WITH BLOCKED CIRCUITS -ALL CIRCUIT SIZES.
 NOT RECOMMENDED FOR MATING WITH MTA-100 CONNECTOR WITHOUT POLARIZING TABS.
 CIRCUIT SIZES 4-19.
- 4 ACCESSORIES:
 REPLACEMENT IDC CONTACTS: 647030-2.
 COVERS: SEE TABLE
- 5 QUANTITY OF CENTRALLY POSITIONED RAILS VARIES WITH CIRCUIT SIZE. (SEE TABLE)
 LOCATION MAY DIFFER FROM EXAMPLE SHOWN.
- 6 DIMENSIONS IN BRACKETS ARE IN INCHES.
- 7 SIMILAR SIZED LOCK AND SINGLE TAB USED OR CIRCUITS 4 & 5.
- 8 QUANTITY OF GUSSET RIBS VARIES WITH CIRCUIT SIZE (SEE TABLE).
 LOCATION MAY DIFFER FROM EXAMPLE SHOWN.
- 9 INNER END RAIL PAIR NOT PRESENT FOR CIRCUIT SIZES 2 OR 3.
- 10 CIRCUIT ID MAY APPEAR FULLY NUMBERED OR SHOWING LOCATION 1 ONLY DEPENDING ON CIRCUIT SIZE.
- 11 OBSOLETE PARTS: OBSOLETE CIS STREAMLINING PER D.RENAUD/D.SINISI

THIS DRAWING IS A CONTROLLED DOCUMENT.		DIN 30-98	
DIMENSIONS: mm [INCHES]		30-98	
TOLERANCES UNLESS OTHERWISE SPECIFIED:		30-98	TE Connectivity
0 PLC	± -	30-98	NAME
1 PLC	± -	30-98	MTA-100 POSTED CONNECTOR ASSEMBLY, CLOSED END, 26 AWG
2 PLC	± 0.20 [.007]	30-98	PRODUCT SPEC
3 PLC	± -	30-98	APPLICATION SPEC
4 PLC	± -	30-98	SIZE
ANGLES	± -	30-98	CAGE CODE
MATERIAL	FINISH	30-98	DRAWING NO
		30-98	A100779C=647010
		30-98	RESTRICTED TO
		30-98	WEIGHT
		30-98	—
		30-98	CUSTOMER DRAWING
		30-98	SCALE 5:1
		30-98	SHEET 1 OF 2
		30-98	REV G

REVISIONS					
P	LTR	DESCRIPTION	DATE	DNW	APVO
-		SEE SHEET 1	-	-	-

					MM	IN	MM	IN	MM	IN	NO. OF CIRCUITS	PART NO
1-640642-9	1-643077-9	4	2	45.72	1.800	48.95	1.927	50.80	2.000	19	4-647010-9	
1-640642-8	1-643077-8	4	2	43.18	1.700	46.41	1.827	48.26	1.900	18	4-647010-8	
1-640642-7	1-643077-7	4	2	40.64	1.600	43.86	1.727	45.72	1.800	17	4-647010-7	
1-640642-6	1-643077-6	4	2	38.10	1.500	41.32	1.627	43.18	1.700	16	4-647010-6	
1-640642-5	1-643077-5	4	2	35.56	1.400	38.78	1.527	40.64	1.600	15	4-647010-5	
1-640642-4	1-643077-4	4	2	33.02	1.300	36.24	1.427	38.10	1.500	14	4-647010-4	
1-640642-3	1-643077-3	4	2	30.48	1.200	33.70	1.327	35.56	1.400	13	4-647010-3	
1-640642-2	1-643077-2	2	1	27.94	1.100	31.16	1.227	33.02	1.300	12	4-647010-2	
1-640642-1	1-643077-1	2	1	25.40	1.000	28.62	1.127	30.48	1.200	11	4-647010-1	
1-640642-0	1-643077-0	2	1	22.86	.900	26.08	1.027	27.94	1.100	10	4-647010-0	
640642-9	643077-9	2	1	20.32	.800	23.54	.927	25.40	1.000	9	3-647010-9	
640642-8	643077-8	2	0	17.78	.700	21.00	.827	22.86	.900	8	3-647010-8	
640642-7	643077-7	0	0	15.24	.600	18.46	.727	20.32	.800	7	3-647010-7	
640642-6	643077-6	0	0	12.70	.500	15.92	.627	17.78	.700	6	3-647010-6	
640642-5	643077-5	0	0	10.16	.400	13.38	.527	15.24	.600	5	3-647010-5	
640642-4	643077-4	0	0	7.62	.300	10.84	.427	12.70	.500	4	3-647010-4	
640642-3	643077-3	0	0	5.08	.200	8.30	.327	10.16	.400	3	3-647010-3	
-	643077-2	0	0	2.54	.100	5.76	.227	7.62	.300	2	3-647010-2	
1-640642-9	1-643077-9	4	2	45.72	1.800	48.95	1.927	50.80	2.000	19	1-647010-9	
1-640642-8	1-643077-8	4	2	43.18	1.700	46.41	1.827	48.26	1.900	18	1-647010-8	
1-640642-7	1-643077-7	4	2	40.64	1.600	43.86	1.727	45.72	1.800	17	1-647010-7	
1-640642-6	1-643077-6	4	2	38.10	1.500	41.32	1.627	43.18	1.700	16	1-647010-6	
1-640642-5	1-643077-5	4	2	35.56	1.400	38.78	1.527	40.64	1.600	15	1-647010-5	
1-640642-4	1-643077-4	4	2	33.02	1.300	36.24	1.427	38.10	1.500	14	1-647010-4	
1-640642-3	1-643077-3	4	2	30.48	1.200	33.70	1.327	35.56	1.400	13	1-647010-3	
1-640642-2	1-643077-2	2	1	27.94	1.100	31.16	1.227	33.02	1.300	12	1-647010-2	
1-640642-1	1-643077-1	2	1	25.40	1.000	28.62	1.127	30.48	1.200	11	1-647010-1	
1-640642-0	1-643077-0	2	1	22.86	.900	26.08	1.027	27.94	1.100	10	1-647010-0	
640642-9	643077-9	2	1	20.32	.800	23.54	.927	25.40	1.000	9	647010-9	
640642-8	643077-8	2	0	17.78	.700	21.00	.827	22.86	.900	8	647010-8	
640642-7	643077-7	0	0	15.24	.600	18.46	.727	20.32	.800	7	647010-7	
640642-6	643077-6	0	0	12.70	.500	15.92	.627	17.78	.700	6	647010-6	
640642-5	643077-5	0	0	10.16	.400	13.38	.527	15.24	.600	5	647010-5	
640642-4	643077-4	0	0	7.62	.300	10.84	.427	12.70	.500	4	647010-4	
640642-3	643077-3	0	0	5.08	.200	8.30	.327	10.16	.400	3	647010-3	
-	643077-2	0	0	2.54	.100	5.76	.227	7.62	.300	2	647010-2	
DUST COVER	STRAIN RELIEF COVERS	QTY OF GUSSET RIBS	QTY OF CENTRAL RAILS	C		B		A		NO. OF CIRCUITS	PART NO	
△4	△5	△8	△5	C		B		A				

SUPERCEDED
 △4
 OBSOLETE
 SUPERCEDED
 △4

THIS DRAWING IS A CONTROLLED DOCUMENT. DIN B LEWIS 30-98
 CJK R SWING 30-98
 APVO J. ELLIS 30-98

TE Connectivity
 MTA-100 POSTED CONNECTOR ASSEMBLY, CLOSED END, 26 AWG

MTA-100 POSTED CONNECTOR ASSEMBLY, CLOSED END, 26 AWG

SIZE: A1 CAGE CODE: 00779 DRAWING NO: 647010
 WEIGHT: -

CUSTOMER DRAWING SCALE: 1:1 SHEET 2 OF 2 REV G