

- ① USE WITH HAND TOOL 220190-1
- ② CABLE USED WITHOUT SPACER.
- ③ CABLE USED WITH SPACER.
- ④ BULK PACKAGE
- 5. SEE I.S. SHEET 9778

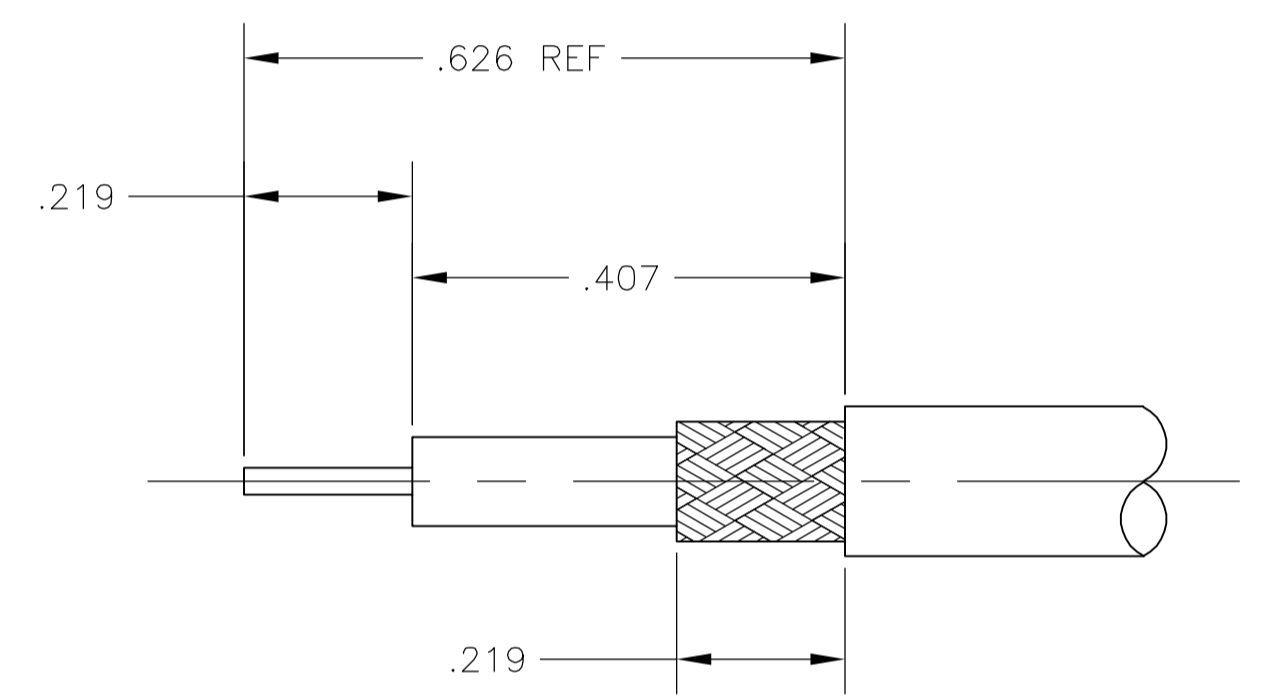
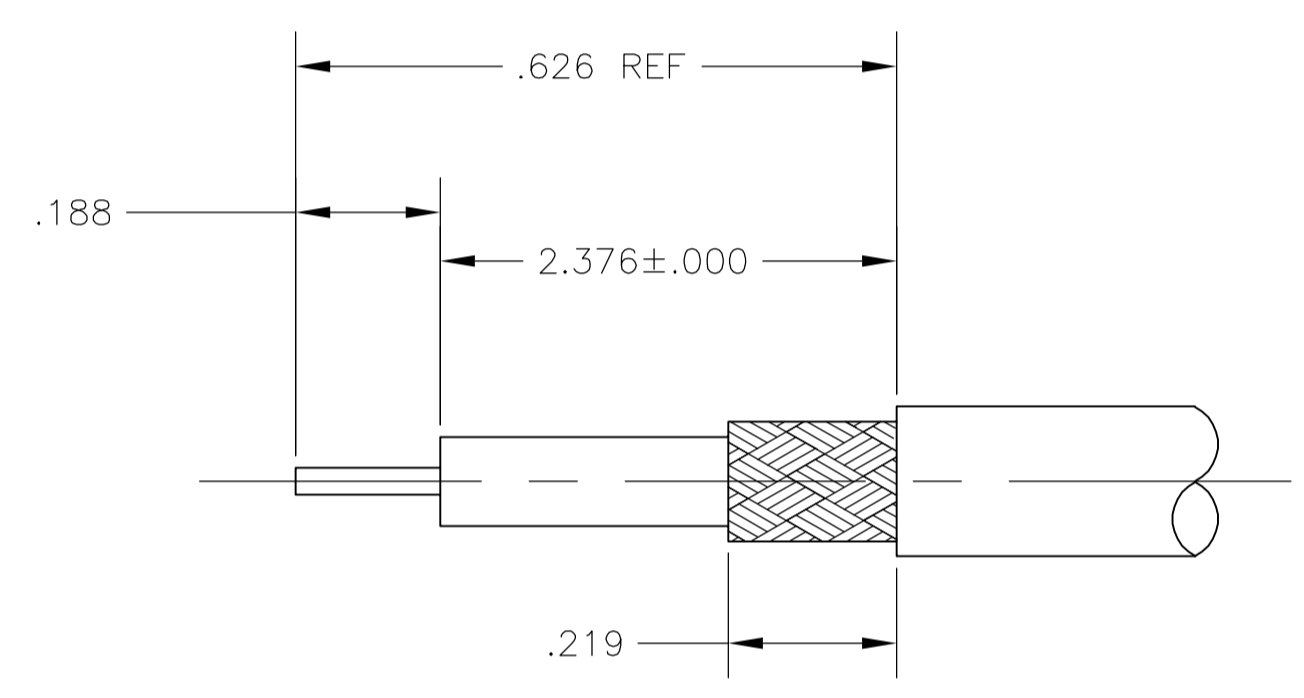
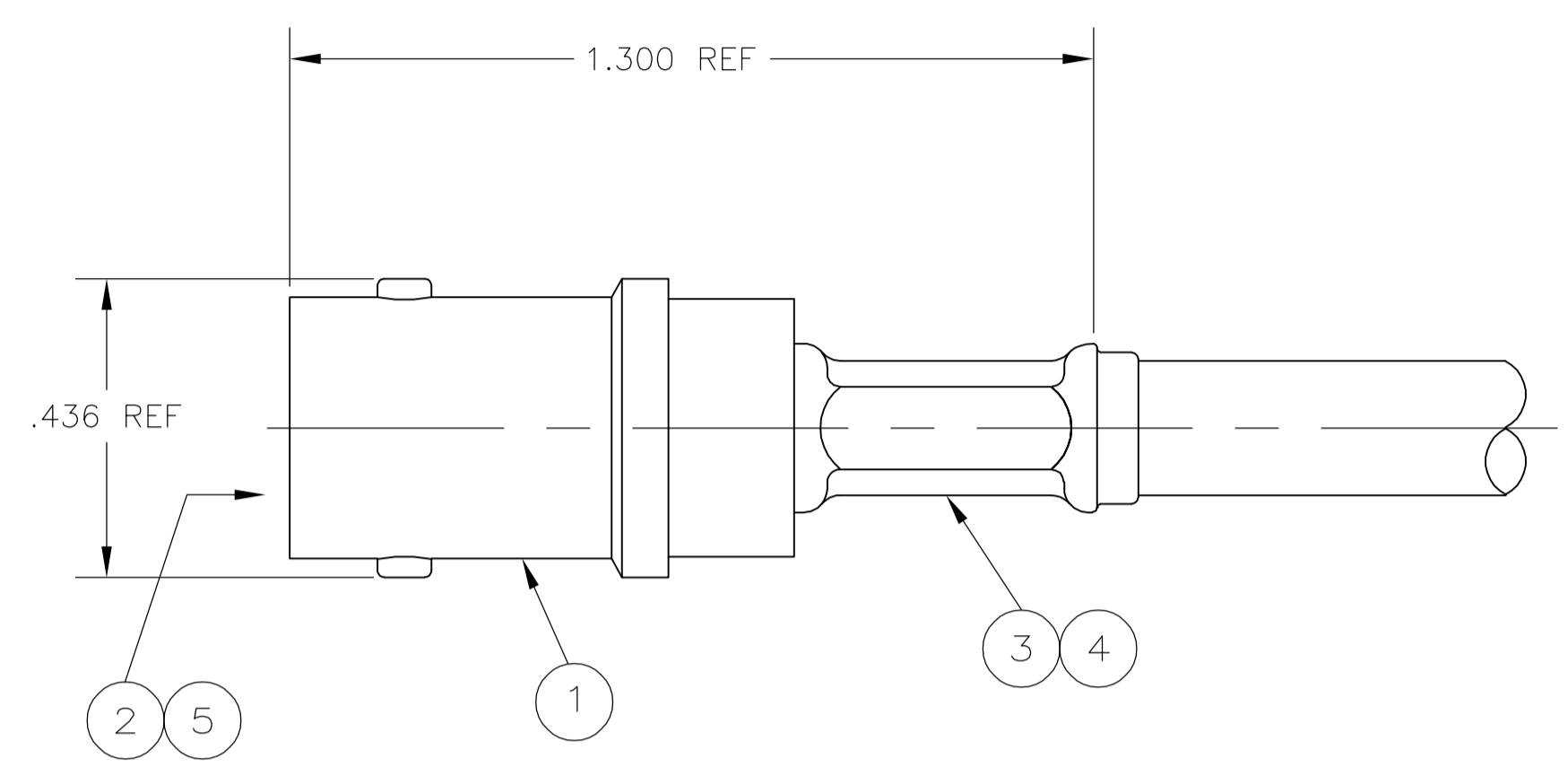

VIEW A

VIEW B

RECOMMENDED STRIP LENGTH

OBSOLETE	BELDEN 89907, 9907 & RG-141	A	.068	.213	58465-3	-	-	9-221132-0	2-413774-5	413780-1	9-413779-1
OBSOLETE	RG-174/U, 188/U & 316/U	B	.068	.178	58465-3	-	21427-2	9-413658-0	1-413774-5	413780-3	9-413779-0
OBSOLETE	BELDEN 89907, 9907 & RG-141	A	.068	.213	58465-3	-	-	9-221132-0	2-413774-5	413780-1	413779-6
OBSOLETE	RG-180 & RG-195	A	.068	.178	58465-3	-	-	9-413658-1	2-413774-0	413780-3	413779-5
OBSOLETE	RG-179U, 179A/U, 179B/U, 187/U & 187A/U	A	.068	.178	58465-3	-	21427-2	9-413658-0	2-413774-0	413780-3	413779-4
△	RG-174/U, 188/U & 316/U	B	.068	.178	58465-3	-	21427-2	9-413658-0	1-413774-5	413780-3	413779-3
OBSOLETE △	RG-59/U, 59A/U, 59B/U, 62/U, 62A/U, 62B/U & BELDEN 88241	A	.068	.255	58465-1	227423-1	-	9-221132-1	1-413774-0	413780-2	413779-2
OBSOLETE	RG-58/U, 58A/U, 58B/U, 58C/U & BELDEN 88240	A	.068	.213	58465-1	-	-	9-221132-0	413774-5	413780-1	413779-1

FOR USE WITH CABLE	VIEW	CONTACT CRIMP (HEX)	FERRULE CRIMP	DIE SET	⑤ SPACER QTY=1	④ TUBING QTY=1	③ FERRULE QTY=1	② CONTACT QTY=1	① JACK ASSEMBLY QTY=1	PART NUMBER
--------------------	------	---------------------	---------------	---------	----------------	----------------	-----------------	-----------------	-----------------------	-------------

THIS DRAWING IS A CONTROLLED DOCUMENT.

DIMENSIONS: INCHES	TOLERANCES UNLESS OTHERWISE SPECIFIED:	DIN J. L. GROFT 06/18/90	Tyco Electronics Corporation Harrisburg, PA 17105-3608
0 PLC ± -	1 PLC ± -	7-2-90	
2 PLC ± -	3 PLC ± -	7-3-90	RESTRICTED TO
4 PLC ± -	ANGLES ± -		
MATERIAL FINISH		APPROVED: S. J. MAGARO	SIZE: A1
		NAME: M. PHILLIPS	SCALE: 4:1
		PRODUCT SPEC	SHEET 1 OF 1
		APPLICATION SPEC	REV G2
		WEIGHT	
		CUSTOMER DRAWING	

JACK, HEX CRIMP, COMMERCIAL BNC
 DRAWING NO: 00779
 PART NO: 413779