

RH-ES Tubular handles

Stainless steel



- 1
- 2
- 3
- 4
- 5
- 6
- 7
- 8
- 9
- 10
- 11
- 12
- 13
- 14
- 15
- 16
- 17
- 18

HANDLE SHANKS

Stainless steel, sandblasted and semi-matte surface obtained by electropolishing.

Through holes for stainless steel screws with hexagonal head, nuts and washers, included in the supply.

TUBE

AISI 304 stainless steel, ground and brushed surface.

TUBE LOCKING

System made up of:

- two grub screws with hexagon socket and cup end;
- non-toxic silicone rubber gasket for food use with working temperature between -60°C and +200°C.

APPLICATIONS

The use of silicone rubber gasket to prevent the penetration of sprays enables the handles to be used for applications which require frequent cleaning cycles.

SPECIAL EXECUTIONS ON REQUEST

Different lengths.



RH-EU Tubular handles

Stainless steel



HANDLE SHANKS

Stainless steel, sandblasted surface, semi-glossy finish obtained by electropolishing.

Threaded holes for hexagonal-head screws and washers, included in the supply.

TUBE

AISI 304 stainless steel, ground surface.

SPECIAL EXECUTIONS ON REQUEST

- Tubular handles for front mounting.
- Plastic coated tube with grooved finish.
- Different lengths.



Conversion Table			
1 mm = 0.039 inch			
L			
mm	inch	mm	inch
225	8.86	376	14.80
226	8.90	425	16.73
276	10.87	426	16.77
325	12.67	525	20.67
326	12.78	625	24.61

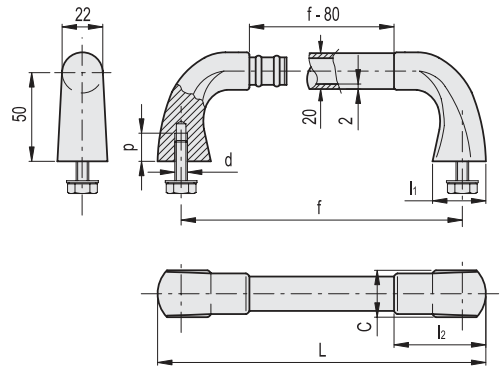
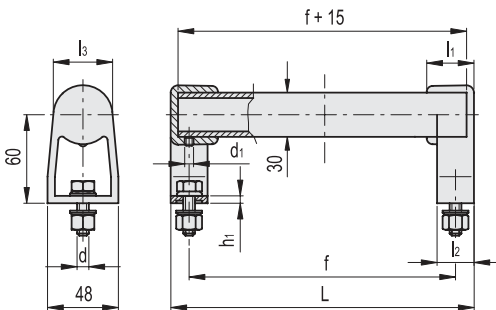

Code	f	d	L	l1	l2	l3	d1	h1	⚖️
RHES-30.200.ST	200	M8x25	225	32	25	40	M6x6	5	808
RHES-30.300.ST	300	M8x25	325	32	25	40	M6x6	5	899
RHES-30.400.ST	400	M8x25	425	32	25	40	M6x6	5	1019
RHES-30.500.ST	500	M8x25	525	32	25	40	M6x6	5	1118
RHES-30.600.ST	600	M8x25	625	32	25	40	M6x6	5	1217

Code	f	d	p	L	C	l1	l2	⚖️
RHEU-20.R200.A	200	M8x20	16	226	26	29	53	705
RHEU-20.R250.A	250	M8x20	16	276	26	29	53	750
RHEU-20.R300.A	300	M8x20	16	326	26	29	53	795
RHEU-20.R350.A	350	M8x20	16	376	26	29	53	840
RHEU-20.R400.A	400	M8x20	16	426	26	29	53	885