

Serial RAM PROTO™

Manual

All Mikroelektronika's development systems feature a large number of peripheral modules expanding microcontroller's range of application and making the process of program testing easier. In addition to these modules, it is also possible to use numerous additional modules linked to the development system through the I/O port connectors. Some of these additional modules can operate as stand-alone devices without being connected to the microcontroller.

Additional board

 **MikroElektronika**

SOFTWARE AND HARDWARE SOLUTIONS FOR EMBEDDED WORLD ...making it simple

Serial RAM PROTO

The Serial RAM PROTO additional board enables the microcontroller to use additional 64Kbit of RAM memory.

Key features:

- Serial SPI communication;
- 64Kbit of RAM;
- 3.3V power supply voltage.



Figure 1: Serial RAM PROTO

How to connect the board?

The Serial RAM PROTO additional board can be easily connected to a microcontroller via a 1x7 connector CN1. Next to each pin of the CN1 connector, there is a designation indicating the function of that pin. Connection with the microcontroller is established via the Serial Peripheral Interface (SPI).

Here you can find examples for the Serial RAM PROTO board:
<http://www.mikroe.com/eng/products/view/442/serialflash-proto-board/>

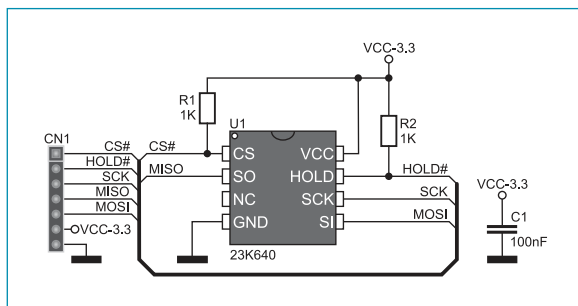

Figure 2: Serial RAM PROTO board connection schematic

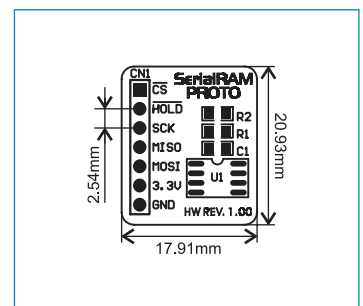

Figure 3: Dimensions of the board



MikroElektronika

SOFTWARE AND HARDWARE SOLUTIONS FOR EMBEDDED WORLD ...making it simple

If you want to learn more about our products, please visit our website at www.mikroe.com

If you are experiencing some problems with any of our products or just need additional information, please place your ticket at www.mikroe.com/en/support

If you have any questions, comments or business proposals, do not hesitate to contact us at office@mikroe.com