

NL3S22AH, NL3S22UH

USB 2.0 + Audio Switch

The NL3S22AH/NL3S22UH is a double-pole/double-throw (DPDT) analog switch for routing high speed differential data and audio. The differential channels are compliant with High Speed USB 2.0, Full Speed USB 1.1, Low Speed USB 1.0 and any generic UART protocol. The multi-purpose audio path is capable of passing signals with negative voltages as low as 3 V below ground and features shunt resistors to reduce Pop and Click noise in the audio system.

For the NL3S22AH, the audio path (AUDP/AUDN) will be selected with SEL=0 with the device enabled (EN = 1). For the NL3S22UH, the high speed data path (HDP/HDN) will be selected with SEL=0 with the device enabled (EN = 1).

Features

- V_{CC} Range: 2.7 V to 3.7 V
- Control Pins Compatible with 1.8 V Interfaces
- I_{CC}: 60 μA (Typ)
- ESD Performance: 2 kV HBM
- Available in 1.4 mm x 1.8 mm UQFN10
- These Devices are Pb-Free, Halogen Free/BFR Free and are RoHS Compliant

High Speed Data Path

- Input Signal Range: 0 V to 4.5 V
- R_{DS(on)}: 5.4 Ω (Typ)
- C_{ON}: 8.7 pF (Typ)
- Data Rate: USB 2.0-Compliant – up to 480 Mbps
- Bandwidth: >811 MHz

Audio Path

- Input Signal Range: -3.0 V to 3.0 V
- R_{DSON}: 0.56 Ω (Typ)
- R_{ON(FLAT)}: 0.004 Ω (Typ)
- THD+N:
 - 113 dB (R_L = 32 Ω / V_{IS} = 1.0 V_{RMS})
 - 109 dB (R_L = 16 Ω / V_{IS} = 0.4 V_{RMS})

Applications

- Smartphones
- Tablets
- USB 2.0 Hosts/Peripherals
- Audio / High-Speeds Data Switching
- USB Type-C Switching



ON Semiconductor®

www.onsemi.com

MARKING DIAGRAM

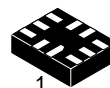

UQFN10
CASE 488AT

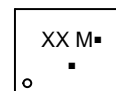

XX = AY for NL3S22AHMUTAG
= DW for NL3S22UHMUTAG

M = Date Code
▪ = Pb-Free Device

(Note: Microdot may be in either location)

ORDERING INFORMATION

Device	Package	Shipping†
NL3S22AHMUTAG	UQFN10 (Pb-Free)	3000 / Tape & Reel
NL3S22UHMUTAG	UQFN10 (Pb-Free)	3000 / Tape & Reel

†For information on tape and reel specifications, including part orientation and tape sizes, please refer to our Tape and Reel Packaging Specification Brochure, BRD8011/D.

NL3S22AH, NL3S22UH

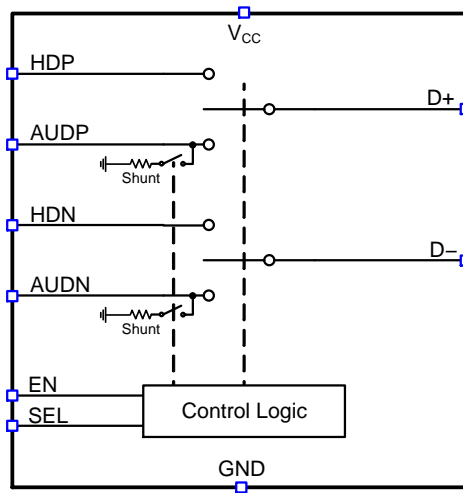

Figure 1. Block Diagram

FUNCTION TABLE

EN	SEL		Shunt Status	D+/D- Function
	NL3S22AH	NL3S22UH		
0	X	X	ON	No Connect (Power Down)
1	0	1	OFF	AUDP/AUDN
1	1	0	ON	HDP/HDN

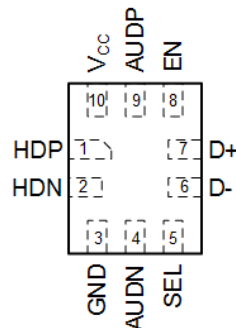

Figure 2. UQFN10 – Top Through View

PIN DESCRIPTION

Pin Name	Pin	Description
HDP	1	High Speed Differential Data (+)
HDN	2	High Speed Differential Data (-)
GND	3	Ground
AUDN	4	Audio Signal (-)
SEL	5	Function Select
D-	6	Audio/Data Common I/O (-)
D+	7	Audio/Data Common I/O (+)
EN	8	Chip Enable
AUDP	9	Audio Signal (+)
V _{CC}	10	Power Supply

NL3S22AH, NL3S22UH

MAXIMUM RATINGS

Rating	Symbol	Value	Unit
V_{CC}	Positive DC Supply Voltage	-0.5 to +4.2	V
V_{IS}	Analog Input/Output Voltage	HDP, HDN -0.5 to +5.5	V
		AUDP, AUDN -3.5 to +4.2	
		D+, D- -3.5 to +5.5	
V_{IN}	Digital Control Pin Voltage on EN, SEL	-0.5 to $V_{CC} + 0.5$	V
T_s	Storage Temperature	-55 to +150	°C
T_L	Lead Temperature, 1 mm from Case for 10 seconds	260	°C
T_J	Junction Temperature Under Bias	150	°C
MSL	Moisture Sensitivity (Note 1)	Level 1	
I_{LU}	Latchup Current (Note 2)	±100	mA
ESD	ESD Protection (Note 3)	Human Body Model	2000
		Charged Device Model	2000

Stresses exceeding those listed in the Maximum Ratings table may damage the device. If any of these limits are exceeded, device functionality should not be assumed, damage may occur and reliability may be affected.

1. Moisture Sensitivity Level (MSL): 1 per IPC/JEDEC standard: J-STD-020A.
2. Latch up Current Maximum Rating: ±100 mA per JEDEC standard: JESD78.
3. This device series contains ESD protection and passes the following tests:
Human Body Model (HBM) ±2.0 kV per JEDEC standard: JESD22-A114 for all pins.

RECOMMENDED OPERATING CONDITIONS

Symbol	Parameter	Min	Max	Unit
V_{CC}	Positive DC Supply Voltage	2.7	3.7	V
V_{IS}	Switch Input / Output Voltage (Note 4)	HDP, HDN	0	4.5
		AUDP, AUDN	-3.0	3.0
		D+, D-	-3.0	4.5
V_{IN}	Digital Control Input Voltage	GND	V_{CC}	V
T_A	Operating Temperature Range	-40	+85	°C

4. If the audio channel is not in use, it is recommended that no signals are applied on the audio inputs AUDN and AUDP.

NL3S22AH, NL3S22UH

DC ELECTRICAL CHARACTERISTICS (Typical values are at $V_{CC} = +3.6\text{ V}$ and $T_A = +25^\circ\text{C}$, unless otherwise specified)

Symbol	Parameter	Test Conditions	V_{CC} (V)	-40 °C to 85 °C			Unit
				Min	Typ	Max	

POWER SUPPLY

I_{CC}	Supply Current	EN = 1, $I_{IS} = 0\text{ mA}$	3.6	-	60	100	μA
		EN = 0 (Power Down)		-	-	1.0	

Control Logic (EN, SEL)

V_{IH}	Input High Voltage		3.6	1.4	-	-	V
			2.7	1.3	-	-	
V_{IL}	Input Low Voltage		3.6	-	-	0.4	V
			2.7	-	-	0.4	
V_{IHYS}	Input Hysteresis		2.7 – 3.6	-	250	-	mV
I_{IN}	Leakage Current		2.7 – 3.6	-	-	± 100	nA

AUDIO SWITCH (AUDP/AUDN ↔ D+/D-)

R_{ON}	ON-Resistance	$V_{IS} = -3.0\text{ V to } 3.0\text{ V}$, $I_{IS} = 50\text{ mA}$	3.0	-	0.56	0.73	Ω
ΔR_{ON}	ON-Resistance Matching Between Channels	$V_{IS} = -3.0\text{ V to } 3.0\text{ V}$, $I_{IS} = 50\text{ mA}$	3.0	-	0.07	-	Ω
$R_{FLAT(ON)}$	ON Resistance Flatness	$V_{IS} = -3.0\text{ V to } 3.0\text{ V}$, $I_{IS} = 50\text{ mA}$	3.0	-	0.004	-	Ω
R_{SH}	Shunt Resistance		3.6	-	110	200	Ω
$I_{SW(OFF)}$	OFF-State Leakage	EN = 0, $V_{IS} = 3.0\text{ V}$ at D+/D-	3.6	-	-	± 200	nA
$I_{SW(ON)}$	ON-State Leakage	$V_{IS} = 0\text{ V to } 3.0$ at D+/D-, AUDP = AUDN = open	3.6	-	± 2.2	± 3.0	μA

DATA SWITCH (HDP/HDN ↔ D+/D-)

R_{ON}	ON-Resistance	$V_{IS} = 0\text{ V to } 1.7\text{ V}$, $I_{IS} = 15\text{ mA}$	3.0	-	5.4	6.63	Ω
ΔR_{ON}	ON-Resistance Matching Between Channels	$V_{IS} = 0\text{ V to } 1.7\text{ V}$, $I_{IS} = 15\text{ mA}$	3.0	-	0.2	-	Ω
$R_{FLAT(ON)}$	ON Resistance Flatness	$V_{IS} = 0\text{ V to } 1.7\text{ V}$, $I_{IS} = 15\text{ mA}$	3.0	-	0.002	-	Ω
$I_{SW(OFF)}$	OFF-State Leakage	EN = 0, $V_{IS} = 0\text{ V to } 3.6\text{ V}$	3.6	-	-	± 200	nA
$I_{SW(ON)}$	ON-State Leakage	$V_{IS} = 0\text{ V to } 3.6\text{ V}$	3.6	-	-	± 200	nA

NL3S22AH, NL3S22UH

AC ELECTRICAL CHARACTERISTICS (Typical values are at $V_{CC} = +3.6\text{ V}$ and $T_A = +25^\circ\text{C}$)

Symbol	Parameter	Test Conditions	V_{CC} (V)	-40 °C to 85 °C			Unit
				Min	Typ	Max	
AUDIO SWITCH (AUDP/AUDN ↔ D+/D-)							
THD	Audio THD	$f = 20\text{ Hz to }20\text{ kHz}$, $V_{IS} = 1.0\text{ V}_{RMS}$, DC Bias = 0 V, $R_L = 32\ \Omega$ $V_{IS} = 0.4\text{ V}_{RMS}$, DC Bias = 0 V, $R_L = 16\ \Omega$	2.7 – 3.6	–	-113 -109	–	dB
PSRR	Power Supply Ripple Rejection	From V_{CC} unto AUDP/AUDN, $f = 217\text{ Hz}$, $R_L = 16\ \Omega$	2.7 – 3.6	–	106	–	dB

DATA SWITCH (HDP/HDN ↔ D+/D-)

C_{ON}	Equivalent ON-Capacitance	Switch ON, $f = 1\text{ MHz}$	3.6	–	8.7	10	pF
C_{OFF}	Equivalent OFF-Capacitance	Switch OFF, $f = 1\text{ MHz}$	3.6	–	1.8	–	pF
D_{IL}	Differential Insertion Loss	$f = 10\text{ MHz}$	2.7 – 3.6	–	-0.5	–	dB
		$f = 800\text{ MHz}$	2.7 – 3.6	–	-2.8	–	
D_{ISO}	Differential Off-Isolation	$f = 10\text{ MHz}$	2.7 – 3.6	–	-54	–	dB
		$f = 800\text{ MHz}$	2.7 – 3.6	–	-25	–	
D_{CTK}	Differential Crosstalk	$f = 10\text{ MHz}$	2.7 – 3.6	–	-62	–	dB
		$f = 800\text{ MHz}$	2.7 – 3.6	–	-28	–	
PSRR	Power Supply Ripple Rejection	From V_{CC} unto D+/D-, $f = 217\text{ Hz}$, $R_L = 50\ \Omega$	2.7 – 3.6	–	111	–	dB

DYNAMIC TIMING

t_{PD}	Propagation Delay (Notes 5 and 6)	V_{NON} or $V_{NCN} = 0\text{ V}$, $R_L = 50\ \Omega$	2.7 – 3.6	–	0.25	–	ns
t_{EN}	Enable Time, EN to HDx EN to AUDx	$V_{IS} = 1\text{ V}$, $R_L = 50\ \Omega$, $C_L = 7\text{ pF}$ (fixture only)	2.7 – 3.6	–	2.1	–	μs
				–	5.1	–	
t_{DIS}	Disable Time, EN to HDx EN to AUDx	$V_{IS} = 1\text{ V}$, $R_L = 50\ \Omega$, $C_L = 7\text{ pF}$ (fixture only)	2.7 – 3.6	–	157	–	ns
				–	53	–	
t_{ON}	Turn-On Time, SEL to HDx SEL to AUDx	$V_{IS} = 1\text{ V}$, $R_L = 50\ \Omega$, $C_L = 7\text{ pF}$ (fixture only)	2.7 – 3.6	–	0.3	–	μs
				–	3.4	–	
t_{OFF}	Turn-Off Time, SEL to HDx SEL to AUDx	$V_{IS} = 1\text{ V}$, $R_L = 50\ \Omega$, $C_L = 7\text{ pF}$ (fixture only)	2.7 – 3.6	–	157	–	ns
				–	44	–	
t_{INIT}	Initialization Time (Notes 5 and 7), V_{CC} to D+/D-	$V_{IS} = 1\text{ V}$, $R_L = 50\ \Omega$, $C_L = 7\text{ pF}$ (fixture only)	2.7 – 3.6	150	–	–	μs
$t_{sk(b-b)}$	Bit to bit skew	Within the same differential channel	2.7 – 3.6	–	5	–	ps
$t_{sk(ch-ch)}$	Channel to channel skew	Maximum skew between all channels	2.7 – 3.6	–	5	–	ps

5. Guaranteed by design.
6. No other delays than the RC network formed by the load resistance and the load capacitance of the switch are added on the bus. For a 10 pF load, this delay is 5 ns which is much smaller than rise and fall time of typical driving systems. Propagation delays on the bus are determined by the driving circuit on the driving side and its interactions with the load of the driven side.
7. Wait time required after V_{CC} power-up to operating level before data access is valid.

NL3S22AH, NL3S22UH

PARAMETER MEASUREMENT INFORMATION

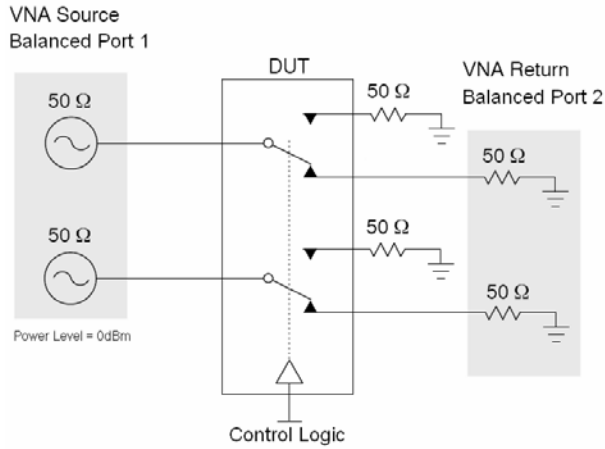

Figure 3. Differential Insertion Loss (S_{DD21})

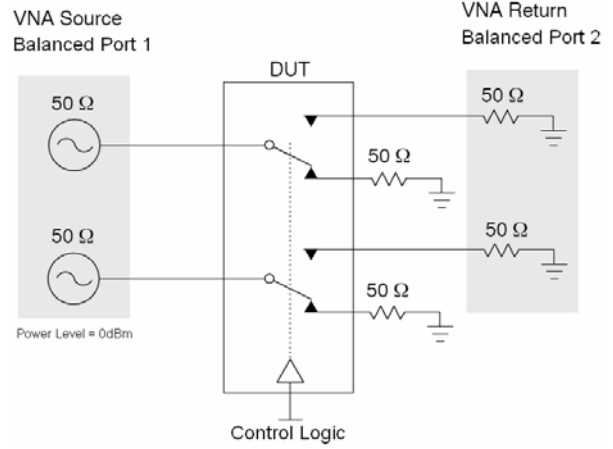

Figure 4. Differential Off Isolation (S_{DD21})

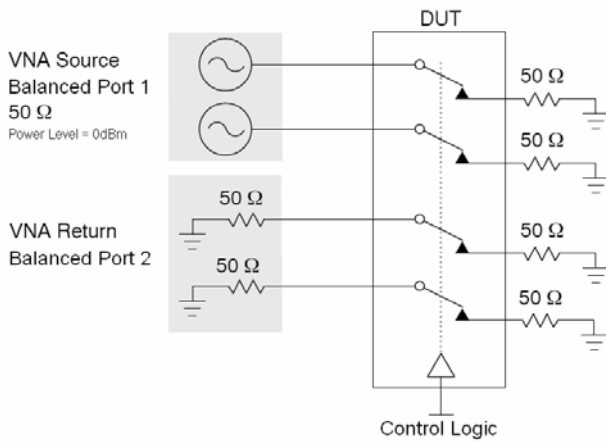
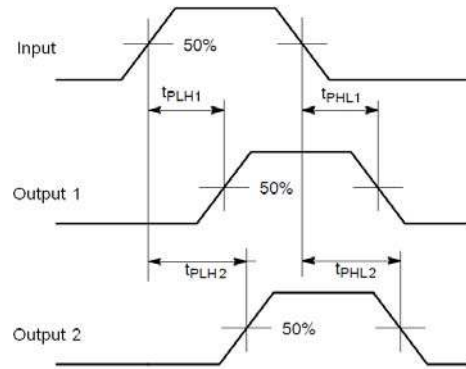

Figure 5. Differential Crosstalk (S_{DD21})



$$t_{skew} = |t_{PLH1} - t_{PLH2}| \text{ or } |t_{PHL1} - t_{PHL2}|$$

Figure 6. Bit-to-Bit and Channel-to-Channel Skew

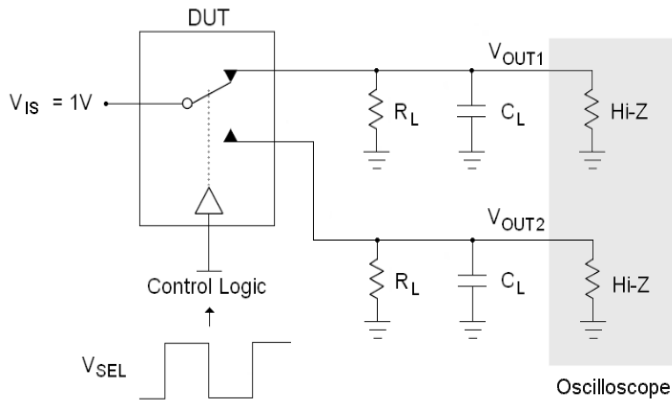

Figure 7. t_{ON} and t_{OFF}

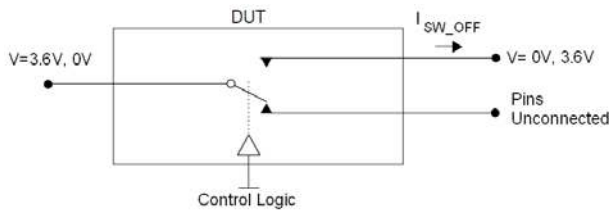
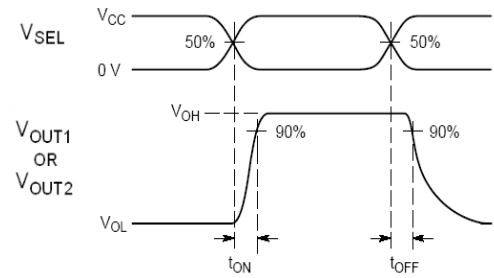

Figure 8. Off State Leakage

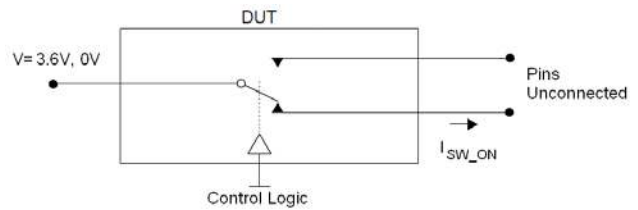

Figure 9. On State Leakage

NL3S22AH, NL3S22UH

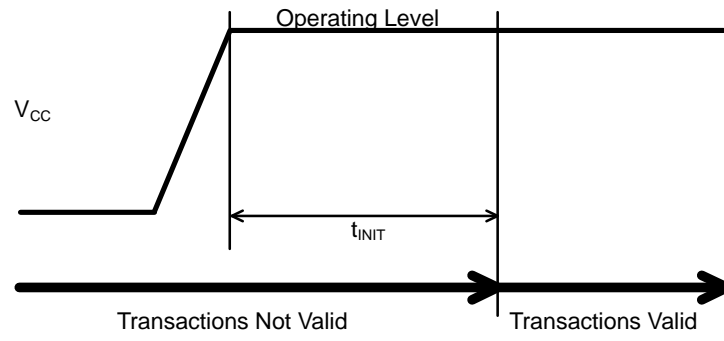

Figure 10. t_{INIT} , Initialization Time

NL3S22AH, NL3S22UH

TYPICAL OPERATING CHARACTERISTICS

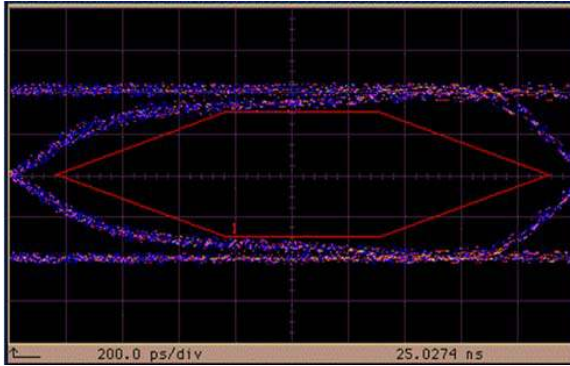

Figure 11. USB 2.0 High Speed Eye Diagram

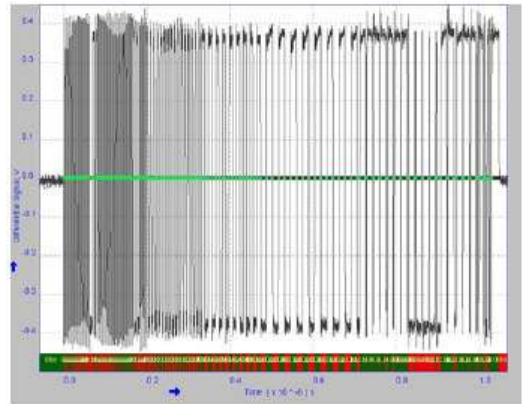

Figure 12. USB 2.0 High Speed Pattern

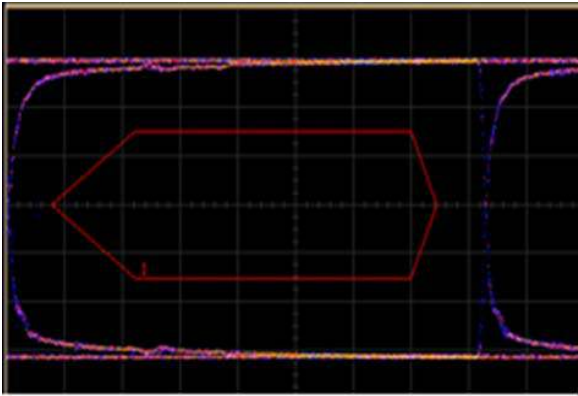

Figure 13. USB 1.1 Full Speed Eye Diagram

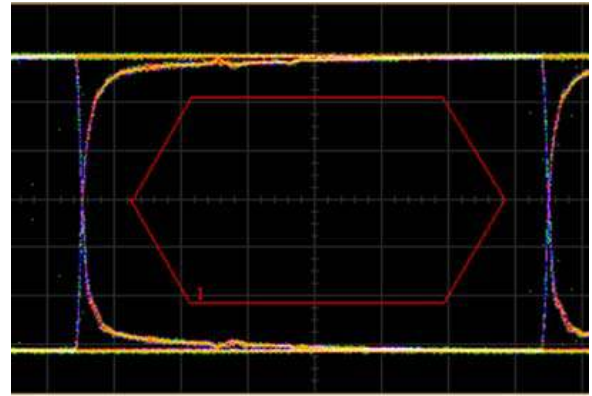

Figure 14. USB 1.0 Low Speed Eye Diagram

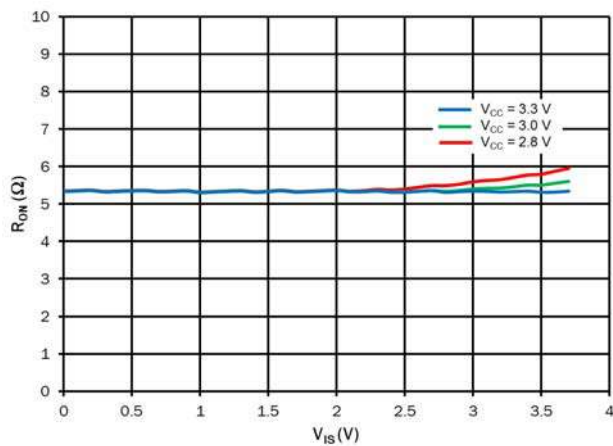

Figure 15. Data Path On Resistance

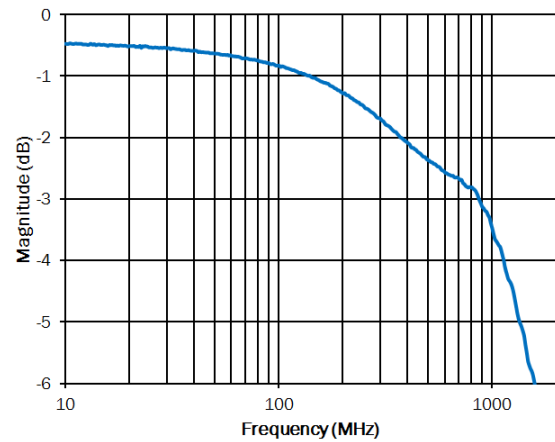

Figure 16. Data Switch Differential Insertion Loss

NL3S22AH, NL3S22UH

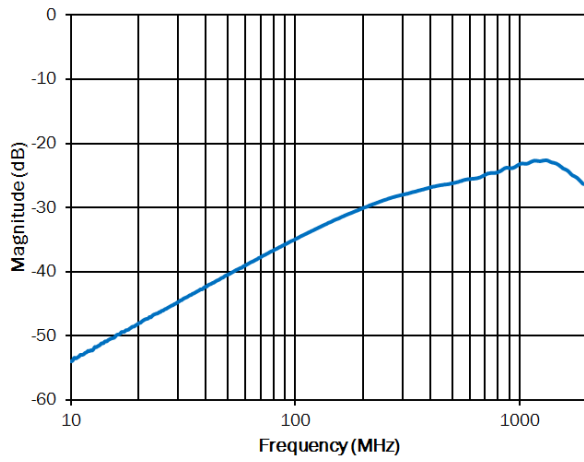

Figure 17. Data Switch Differential Off-Isolation

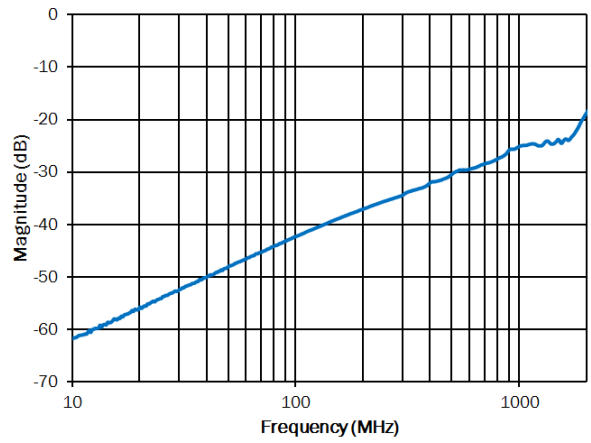

Figure 18. Data Switch Differential Crosstalk

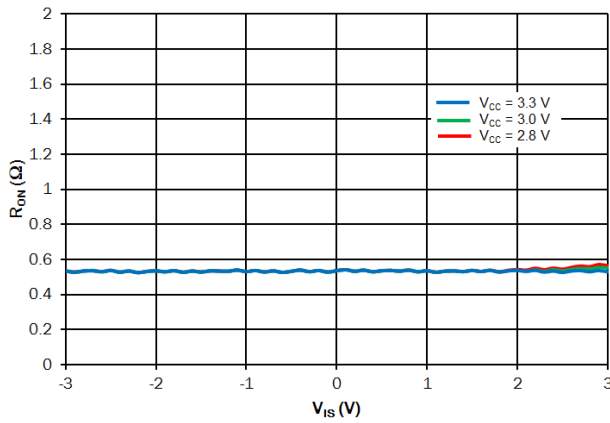
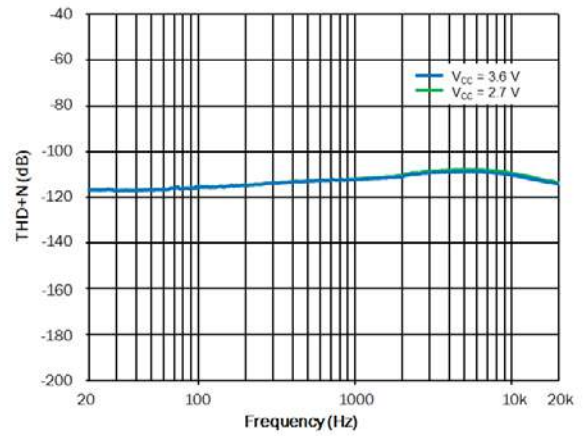
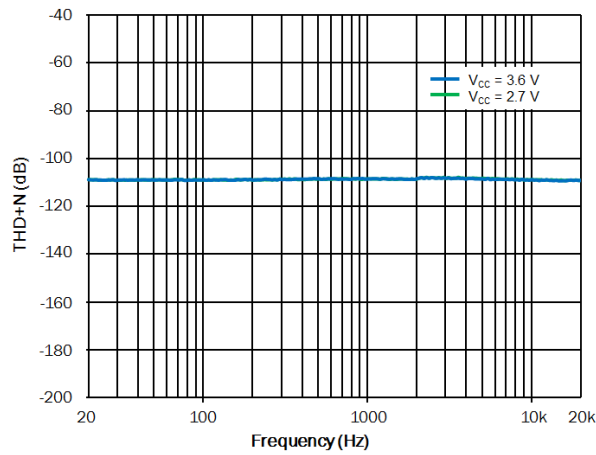

Figure 19. Audio Path On Resistance



**Figure 20. Audio THD+N
($R_L = 32 \Omega$, $V_{IS} = 1.0 V_{RMS}$)**



**Figure 21. Audio THD+N
($R_L = 16 \Omega$, $V_{IS} = 0.4 V_{RMS}$)**

MECHANICAL CASE OUTLINE

PACKAGE DIMENSIONS

ON Semiconductor®



UQFN10 1.4x1.8, 0.4P CASE 488AT-01 ISSUE A

DATE 01 AUG 2007

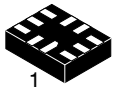

SCALE 5:1

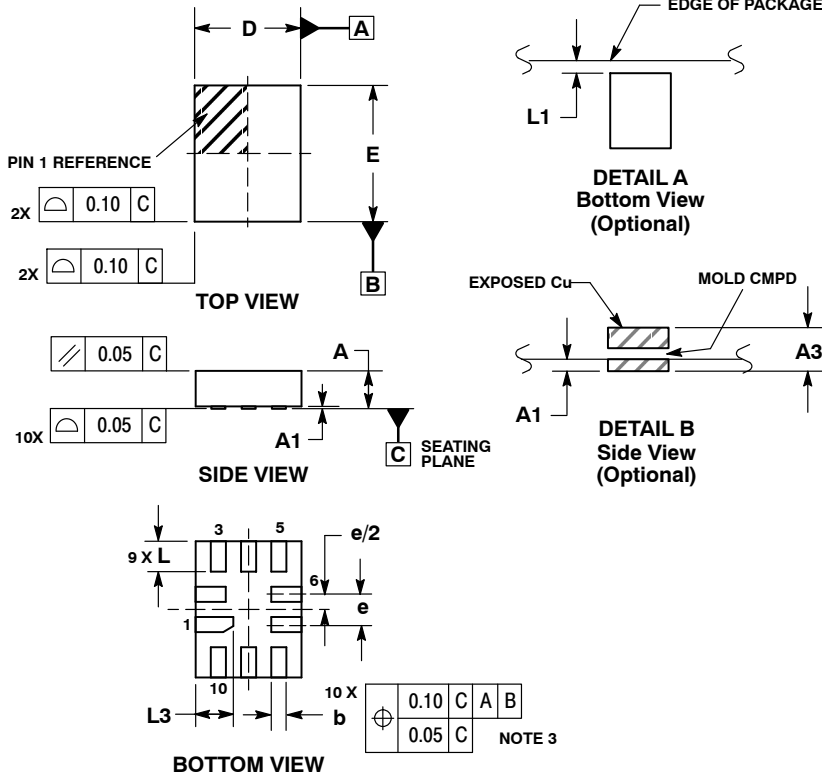

NOTES:

1. DIMENSIONING AND TOLERANCING PER ASME Y14.5M, 1994.
2. CONTROLLING DIMENSION: MILLIMETERS
3. DIMENSION b APPLIES TO PLATED TERMINAL AND IS MEASURED BETWEEN 0.25 AND 0.30 MM FROM TERMINAL.
4. COPLANARITY APPLIES TO THE EXPOSED PAD AS WELL AS THE TERMINALS.

GENERIC MARKING DIAGRAM*

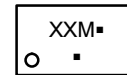

- XX = Specific Device Code
 - M = Date Code
 - = Pb-Free Package
- (Note: Microdot may be in either location)

*This information is generic. Please refer to device data sheet for actual part marking. Pb-Free indicator, "G" or microdot "▪", may or may not be present.

MOUNTING FOOTPRINT

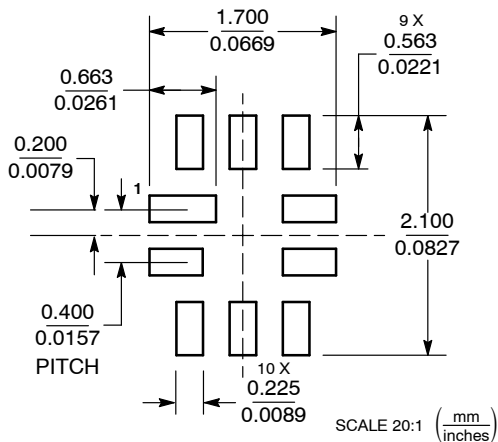

DOCUMENT NUMBER:	98AON22493D	Electronic versions are uncontrolled except when accessed directly from the Document Repository. Printed versions are uncontrolled except when stamped "CONTROLLED COPY" in red.
DESCRIPTION:	10 PIN UQFN, 1.4 X 1.8, 0.4P	PAGE 1 OF 1

ON Semiconductor and ON are trademarks of Semiconductor Components Industries, LLC dba ON Semiconductor or its subsidiaries in the United States and/or other countries. ON Semiconductor reserves the right to make changes without further notice to any products herein. ON Semiconductor makes no warranty, representation or guarantee regarding the suitability of its products for any particular purpose, nor does ON Semiconductor assume any liability arising out of the application or use of any product or circuit, and specifically disclaims any and all liability, including without limitation special, consequential or incidental damages. ON Semiconductor does not convey any license under its patent rights nor the rights of others.

onsemi, **Onsemi**, and other names, marks, and brands are registered and/or common law trademarks of Semiconductor Components Industries, LLC dba "**onsemi**" or its affiliates and/or subsidiaries in the United States and/or other countries. **onsemi** owns the rights to a number of patents, trademarks, copyrights, trade secrets, and other intellectual property. A listing of **onsemi**'s product/patent coverage may be accessed at www.onsemi.com/site/pdf/Patent-Marking.pdf. **onsemi** reserves the right to make changes at any time to any products or information herein, without notice. The information herein is provided "as-is" and **onsemi** makes no warranty, representation or guarantee regarding the accuracy of the information, product features, availability, functionality, or suitability of its products for any particular purpose, nor does **onsemi** assume any liability arising out of the application or use of any product or circuit, and specifically disclaims any and all liability, including without limitation special, consequential or incidental damages. Buyer is responsible for its products and applications using **onsemi** products, including compliance with all laws, regulations and safety requirements or standards, regardless of any support or applications information provided by **onsemi**. "Typical" parameters which may be provided in **onsemi** data sheets and/or specifications can and do vary in different applications and actual performance may vary over time. All operating parameters, including "Typicals" must be validated for each customer application by customer's technical experts. **onsemi** does not convey any license under any of its intellectual property rights nor the rights of others. **onsemi** products are not designed, intended, or authorized for use as a critical component in life support systems or any FDA Class 3 medical devices or medical devices with a same or similar classification in a foreign jurisdiction or any devices intended for implantation in the human body. Should Buyer purchase or use **onsemi** products for any such unintended or unauthorized application, Buyer shall indemnify and hold **onsemi** and its officers, employees, subsidiaries, affiliates, and distributors harmless against all claims, costs, damages, and expenses, and reasonable attorney fees arising out of, directly or indirectly, any claim of personal injury or death associated with such unintended or unauthorized use, even if such claim alleges that **onsemi** was negligent regarding the design or manufacture of the part. **onsemi** is an Equal Opportunity/Affirmative Action Employer. This literature is subject to all applicable copyright laws and is not for resale in any manner.

ADDITIONAL INFORMATION

TECHNICAL PUBLICATIONS:

Technical Library: www.onsemi.com/design/resources/technical-documentation
onsemi Website: www.onsemi.com

ONLINE SUPPORT: www.onsemi.com/support

For additional information, please contact your local Sales Representative at www.onsemi.com/support/sales