

3A, 16V Driver Transistor Built-In Step-Down DC/DC Converter

☆Green Operation Compatible

■ GENERAL DESCRIPTION

The XCM526 series is a multi-module IC which includes a step-down DC/DC controller IC and P-channel power MOSFET. The IC enables a high efficiency, stable power supply with an output current up to 3A. Low ESR electrolytic capacitors such as an OS-CON aluminum solid capacitor, a tantalum Neo capacitor can be used as an output capacitor. In case of using a ceramic capacitor, RSENSE is needed to be placed on.

The XCM526 series has a 0.9V ($\pm 1.5\%$) reference voltage, and using externally connected resistors, the output voltage can be set freely. With an internal switching frequency of 500kHz and 1.0MHz, small external components can also be used. The XCM526A has a fixed PWM control for low output voltage ripple, and the XCM526B has a PWM/PFM control, which automatically switches from PWM to PFM during light loads and high efficiencies can be achieved over a wide range of load conditions. As for the soft-start time, there are two types, one is internally set to 4ms and the other can be externally set-up. With the built-in UVLO (Under Voltage Lock Out) function, the internal P-channel driver transistor is forced OFF when input voltage becomes 2.3V (TYP.) or lower.

■ APPLICATIONS

- LCD TVs
- DSC/DVCs
- Portable games
- Portable equipments

■ FEATURES

<DC/DC Block>

Operating Voltage Range	: 4.0V ~ 16.0V
Output Voltage Externally Set Range	: 1.2V ~ (standard 0.9V $\pm 1.5\%$)
Maximum Output Current	: 3.0A
Oscillation Frequency	: 500kHz, 1.0MHz
Control Methods	: PWM control (XCM526A) PWM/PFM automatic switching (XCM526B)

Soft-Start Function	: 4ms internally fixed and externally set
Protection Circuits	: Short-circuit protection

<Power MOSFET Block>

ON Resistance	: 70m Ω ($V_{GS} = -4.5V$) 47m Ω ($V_{GS} = -10.0V$)
Package	: USP-12B01 (2.3mm x 2.8mm)
Environmentally Friendly	: EU RoHS Compliant, Pb Free

■ TYPICAL APPLICATION CIRCUIT

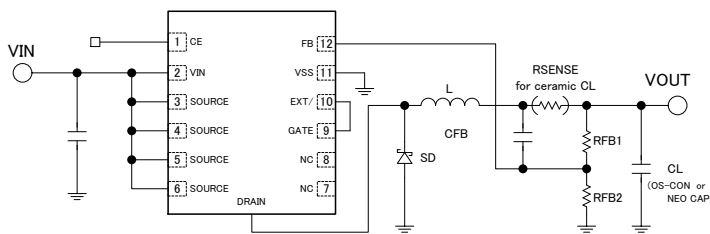

(TOP VIEW)

■ TYPICAL PERFORMANCE CHARACTERISTICS

XCM526Ax/Bx9Axx

SBD:CLS01, L=SLF10165T-4.7 μ H
 CIN=22 μ F (ceramic), CL=47 μ F (ceramic), RSENSE=50m Ω
 VOUT=3.3V

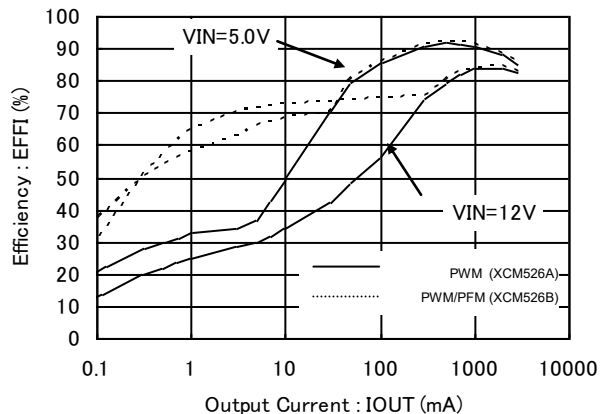

PIN CONFIGURATION

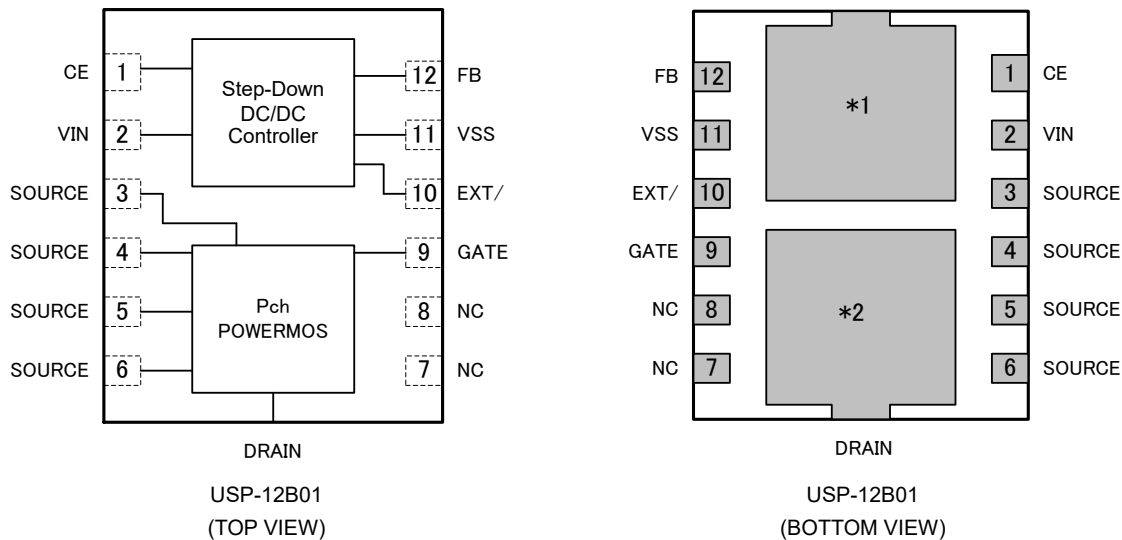

NOTE:

* A dissipation pad on the back side should be electrically isolated between the two chips.

*1: Voltage level of the DC/DCs' dissipation pad should be V_{SS} level.

*2: P-channel Power MOS should be DRAIN level.

Care must be taken for a voltage level of each dissipation pad so as to enhance mounting strength and thermal release when the pad needs to be connected to the circuit.

PIN ASSIGNMENT

PIN No.	PIN NAME	FUNCTION
1	CE	DC/DC Block, Chip Enable
2	VIN	DC/DC Block, Power Supply
3	SOURCE	POWER MOS SOURCE
4	SOURCE	POWER MOS SOURCE
5	SOURCE	POWER MOS SOURCE
6	SOURCE	POWER MOS SOURCE
7	NC	No Connection
8	NC	No Connection
9	GATE	POWER MOS GATE
10	EXT/	DC/DC Block, Transistor Drive
11	VSS	DC/DC Block, Ground
12	FB	DC/DC Block, Output Voltage Sense
Back Side TAB ^(*)	DRAIN	POWER MOS DRAIN

■ PRODUCT CLASSIFICATION

● Ordering Information

XCM526A①②③④⑤-⑥^(*1): PWM control

XCM526B①②③④⑤-⑥^(*1): PWM/PFM automatic switching control

DESIGNATOR	ITEM	SYMBOL	DESCRIPTION
①	Type	C	Soft-start internally fixed
		D	Soft-start externally set
②	Output Voltage	9	FB Standard Voltage $0.9V \pm 1.5\%$
③	Oscillation Frequency ^(*2)	5	500kHz
		A	1.0MHz
④⑤-⑥ ^(*1)	Package (Order Unit)	DR-G	USP-12B01 (3,000pcs/Reel)

(*1) The XCM526 series is Halogen and Antimony free as well as being fully EU RoHS compliant.

(*2) For the 300kHz type is semi-custom product. Please contact your local Torex sales office or representative.

■ BLOCK DIAGRAMS

● XCM526xC Series

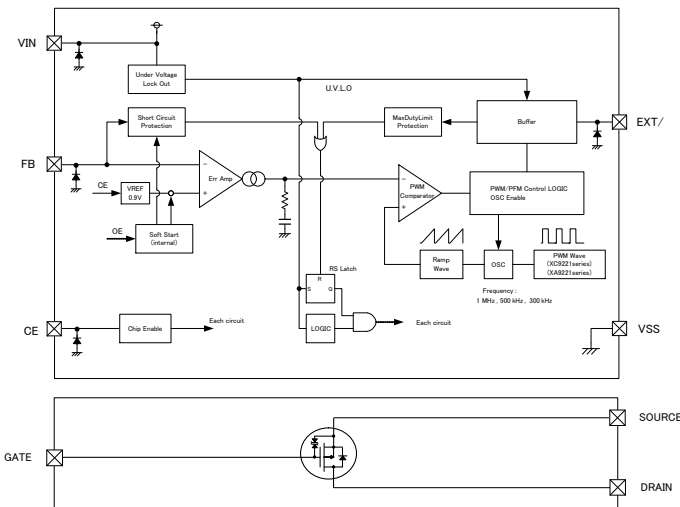

● XCM526xD Series

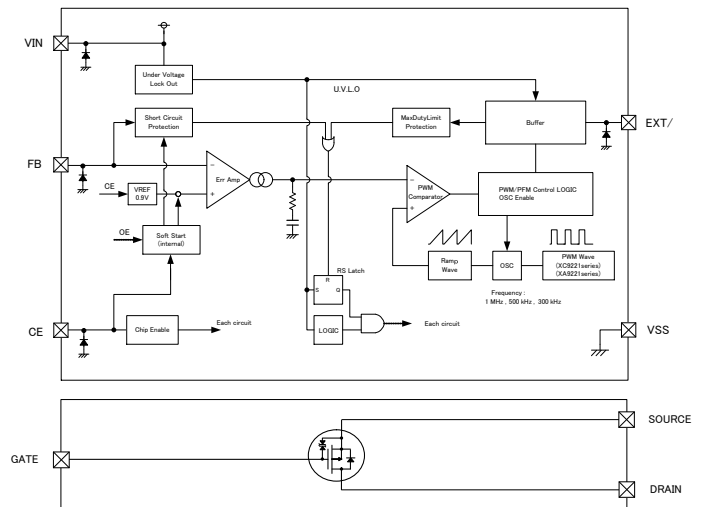

* Diodes inside the circuits are ESD protection diodes and parasitic diodes.

■ ABSOLUTE MAXIMUM RATINGS

Ta = 25°C

PARAMETER	SYMBOL	RATINGS	UNITS
V _{IN} Pin Voltage	V _{IN}	-0.3 ~ 18	V
FB Pin Voltage	V _{FB}	-0.3 ~ 18	V
CE Pin Voltage	V _{CE}	-0.3 ~ 18	V
EXT/ Pin Voltage	V _{EXT/}	-0.3 ~ V _{IN} + 0.3	V
EXT/ Pin Current	I _{EXT/}	±100	mA
Drain-Source Voltage	V _{DSS}	-30	V
Gate-Source Voltage	V _{GSS}	±20	V
Drain Current (DC)	I _D	-5	A
Drain Current (Pulse) ^(*1)	I _{DP}	-12	A
Power Dissipation	USP-12B01	150 (1C only)	mW
	USP-12B01 (PCB mounted) ^(*2)	800 (1ch operation)	
		600 (2ch operation)	
Operating Temperature Range	T _{opr}	-40 ~ 85	°C
Storage Temperature Range	T _{stg}	-55 ~ 125	°C

(*1) PW ≤ 10 μs, duty cycle ≤ 1%

(*2) The power dissipation figure shown is PCB mounted and is for reference only.
Please refer to PACKAGING INFORMATION for the mounting condition.

■ ELECTRICAL CHARACTERISTICS

XCM526AC/BC Series (DC/DC Controller)

Ta=25°C

PARAMETER	SYMBOL	CONDITIONS	MIN.	TYP.	MAX.	UNITS	CIRCUIT
FB Voltage	V _{FB}		0.8865	0.9000	0.9135	V	②
Input Voltage Range	V _{IN}		4.0	-	16.0	V	-
UVLO Voltage (Minimum Operating Voltage)	V _{UVLO}		1.9	2.3	2.7	V	③
Supply Current 2	I _{DD2}	V _{IN} =5.0V, V _{FB} =1.0V	* See the Oscillation Frequency chart below.			μA	①
Stand-by Current	I _{STB}		-	0.1	1.0	μA	①
Oscillation Frequency	f _{OSC}	Connected to external components	* See the Oscillation Frequency chart below.			kHz	③
Maximum Duty Ratio	D _{MAX}		100	-	-	%	②
PFM Duty Ratio	D _{PFM}	No load (XCM526B)	15	25	35	%	③
EXT/ High ON Resistance	R _{EXTBH}		6	10	16	Ω	④
EXT/ Low ON Resistance	R _{EXTBL}		6	12	20	Ω	④
Short-Circuit Protection	V _{SHORT}		-	-	0.7	V	②
Soft-Start Time	t _{SS}		* See the Oscillation Frequency chart below.			ms	②
Efficiency (*1)	EFFI	I _{OUT} =500mA	-	92	-	%	③
FB Voltage Temperature Characteristics	$\frac{\Delta V_{FB}}{(\Delta T_{opr} \cdot V_{FB})}$		-	±100	-	ppm/°C	②
CE "H" Level Voltage	V _{CEH}		1.2	-	16.0	V	②
CE "L" Level Voltage	V _{CEL}		V _{SS}	-	0.3	V	②
CE "H" Level Current	I _{CEH}	V _{IN} = V _{CE} =16V	-0.1	-	0.1	μA	①
CE "L" Level Current	I _{CEL}	V _{IN} =16V, V _{CE} =0V	-0.1	-	0.1	μA	①
FB "H" Level Current	I _{FBH}	V _{IN} =V _{FB} =16V	-0.1	-	0.1	μA	④
FB "L" Level Current	I _{FBL}	V _{IN} =16V, V _{FB} =0V	-0.1	-	0.1	μA	④

Unless otherwise stated, V_{IN}=5.0V

NOTE:

(*1) EFFI = { (output voltage) x (output current) } / { (input voltage) x (input current) } x 100

ELECTRICAL CHARACTERISTICS (Continued)

XCM526AD/BD Series (DC/DC Controller)

Ta=25°C

PARAMETER	SYMBOL	CONDITIONS	MIN.	TYP.	MAX.	UNITS	CIRCUIT
FB Voltage	V _{FB}		0.8865	0.9000	0.9135	V	②
Input Voltage Range	V _{IN}		4.0		16.0	V	-
UVLO Voltage (Minimum Operating Voltage)	V _{UVLO}		1.9	2.3	2.7	V	③
Supply Current 2	I _{DD2}	V _{IN} =5.0V, V _{FB} =1.0V	* See the Oscillation Frequency chart below.			μA	①
Stand-by Current	I _{STB}			0.1	1.0	μA	①
Oscillation Frequency	f _{OSC}	Connected to external components	* See the Oscillation Frequency chart below.			kHz	③
Maximum Duty Ratio	D _{MAX}		100			%	②
PFM Duty Ratio	D _{PFM}	No load (XCM526B)	15	25	35	%	③
EXT/ High ON Resistance	R _{EXTBH}		6	10	16	Ω	④
EXT/ Low ON Resistance	R _{EXTBL}		6	12	20	Ω	④
Short-Circuit Protection	V _{SHORT}				0.7	V	②
Soft-Start Time	t _{SS}	Connected to R _{SS} and C _{SS}	5.0	10.0	20.0	ms	⑤
Internal Soft-Start Time (*1)	t _{SS_IN}	V _{CE} =V _{IN}	* See the Oscillation Frequency chart below.			ms	②
Efficiency (*2)	EFFI	I _{OUT} =500mA		92		%	③
FB Voltage Temperature Characteristics	ΔV _{FB} / (ΔT _{opr} ·V _{FB})			±100		ppm/°C	②
CE "H" Level Voltage (*3)	V _{CEH}		2.6		16.0	V	②
CE "L" Level Voltage	V _{CEL}		V _{SS}		0.3	V	②
CE "H" Level Current	I _{CEH}	V _{IN} = V _{CE} =16V	-0.1		0.1	μA	①
CE "L" Level Current	I _{CEL}	V _{IN} =16V, V _{CE} =0V	-0.1		0.1	μA	①
FB "H" Level Current	I _{FBH}	V _{IN} = V _{FB} =16V	-0.1		0.1	μA	④
FB "L" Level Current	I _{FBL}	V _{IN} =16V, V _{FB} =0V	-0.1		0.1	μA	④

Unless otherwise stated, V_{IN}=5.0V

External components: C_{SS}=0.1 μF, R_{SS}=200kΩ

NOTE:

(*1) Internal soft-start time: In case where the UVLO function operates temporarily due to the power cutoff etc. The IC restarts operation by the internal soft-start time. Minimum value of soft-start time set externally is equal to the internal soft-start time under the condition of charged external C_{SS} (V_{CE}≥2.6V).

(*2) EFFI={ (output voltage) x (output current) } / { (input voltage) x (input current) } x 100

(*3) The integral latch and short-circuit protection do not operate while when the CE/CSS pin voltage is lower than 2.6V (while a soft-start time).

CHARACTERISTICS CHART BY OSCILLATION FREQUENCY

PARAMETER	SYMBOL	500kHz			1.0MHz		
		MIN.	TYP.	MAX.	MIN.	TYP.	MAX.
Supply Current 2	I _{DD2}	-	25	50	-	40	80
Oscillation Frequency	f _{OSC}	425	500	575	850	1000	1150
Soft-Start Time	t _{SS}	2	4	8	1	2	4

■ ELECTRICAL CHARACTERISTICS (Continued)

XCM526 Series (P-ch MOSFET)

PARAMETER	SYMBOL	CONDITIONS	MIN.	TYP.	MAX.	UNITS	CIRCUIT
Drain-Source Breakdown Voltage	$V_{(BR)DSS}$	$I_D=-1mA, V_{GS}=0V$	-30	-	-	V	⑥
Drain-Source Cutoff Current	I_{GSS}	$V_{DS}=-30V, V_{GS}=0V$	-	-	-1	μA	⑦
Gate-Source Leakage Current	I_{GSS}^+	$V_{GS}=16V, V_{DS}=0V$	-	-	10	μA	⑧
	I_{GSS}^-	$V_{GS}=-16V, V_{DS}=0V$	-	-	-10	μA	⑨
Drain-Source Breakdown Voltage	$V_{GS(off)}$	$V_{DS}=-10V, I_D=-1mA$	-1.2	-	-2.6	V	⑩
Forward Transfer Admittance ^(*1)	$ y_{fs} $	$V_{DS}=-10V, I_D=-3A$	-	8.0	-	S	⑪
Drain-Source On-Resistance ^(*1)	$R_{DS(ON)1}$	$I_D=-3A, V_{GS}=-10V$	-	47	59	m Ω	⑫
	$R_{DS(ON)2}$	$I_D=-1.5A, V_{GS}=-4.5V$	-	70	100	m Ω	
	$R_{DS(ON)3}$	$I_D=-1.5A, V_{GS}=-4V$	-	80	113	m Ω	
Input Capacitance	C_{iss}	$V_{DS}=-10V, f=1MHz$	-	450	-	pF	⑬
Output Capacitance	C_{oss}	$V_{DS}=-10V, f=1MHz$	-	110	-	pF	
Feedback Capacitance	C_{rss}	$V_{DS}=-10V, f=1MHz$	-	80	-	pF	
Turn On Delay Time	$t_{d(on)}$	$I_D=-3A$	-	7	-	ns	⑭
Rising Time	t_r	$I_D=-3A$	-	8	-	ns	
Turn Off Delay Time	$t_{d(off)}$	$I_D=-3A$	-	31	-	ns	
Falling Time	t_f	$I_D=-3A$	-	6	-	ns	
Total Gate Charge ^(*1)	Q_g	$V_{DS}=-15V, V_{GS}=-10V, I_D=-5A$	-	10	-	nC	⑮
Gate-Source Charge ^(*1)	Q_{gs}	$V_{DS}=-15V, V_{GS}=-10V, I_D=-5A$	-	1.5	-	nC	
Gate-Drain Charge ^(*1)	Q_{gd}	$V_{DS}=-15V, V_{GS}=-10V, I_D=-5A$	-	2.5	-	nC	
Diode Forward Voltage ^(*1)	V_{SD}	$I_S=-5A, V_{GS}=0V$	-	-0.9	-1.2	V	⑯

(*1) Pulse condition: $PW \leq 250 \mu s$, duty cycle $\leq 1\%$

TYPICAL APPLICATION CIRCUITS

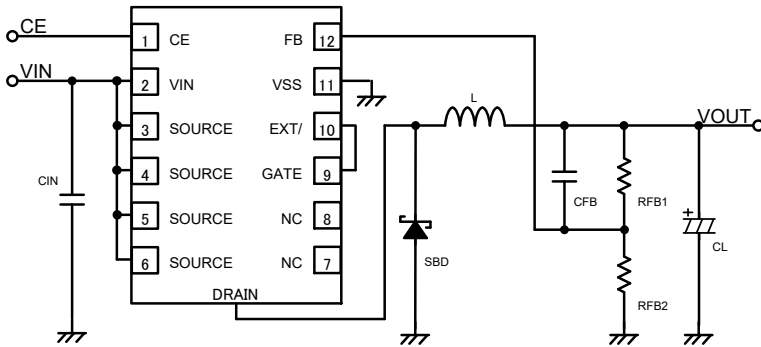

<External Components>

SBD : CLS01(TOSHIBA)
 L : SLF10165T-4R7N4R73PF(4.7 μH,TDK/ fosc=1.0MHz)
 RLF12545T-100M5R1(10 μH,TDK / fosc=500kHz)
 CIN : 22 μF(EMK316BJ226ML /YUDEN)
 CL : 47 μF or higher
 (10SVP47M /SANYO fosc=500kHz, 1.0MHz)

● Output Voltage Setting

Output voltage can be set by adding split resistors. Output voltage is determined by the following equation, based on the values of RFB1 and RFB2. The sum of RFB1 and RFB2 should normally be 1MΩ or less.

$$V_{OUT} = 0.9 \times (R_{FB1} + R_{FB2}) / R_{FB2} \dots \textcircled{1}$$

The value of CFB, speed-up capacitor for phase compensation, should be adjusted by the following equation. fzfb should usually be 5kHz. Adjustments are required from 1kHz to 20kHz depending on the application, value of inductance (L), and value of load capacitance (CL).

$$C_{FB} = 1 / (2 \times \pi \times R_{FB1} \times f_{zfb}) \dots \textcircled{2}$$

[Sample calculation: to set VOUT=3.3V]

$$R_{FB1} = 200k\Omega, R_{FB2}=75k\Omega, V_{OUT} = 0.9 \times (200k + 75k) / 75k = 3.300V$$

$$C_{FB} = 1 / (2 \times \pi \times 200k \times 5k) = 150pF$$

[Typical examples]

VOUT (V)	RFB1 (kΩ)	RFB2 (kΩ)	CFB (pF)	VOUT (V)	RFB1 (kΩ)	RFB2 (kΩ)	CFB (pF)
1.2	100	300	330	3.3	200	75	150
1.5	180	270	180	5.0	150	33	220
1.8	220	220	150	12.0	160	13	180

● Recommended SBD (Examples)

IOUT	UP to 1A	UP to 3A
SBD	XBS204S17R(TOREX) CMS05(TOSHIBA)	CLS01(TOSHIBA)

(*1) SBD should be used with good reverse characteristics.

■ TYPICAL APPLICATION CIRCUITS (Continued)

● Ceramic Capacitor

With the XCM526 series, a ceramic capacitor can be used as an output capacitor (C_L). R_{SENSE} resistor is required for using the ceramic capacitor. The value of R_{SENSE} resistor is determined depending on the setting output voltage as the chart below.

	R _{SENSE} (mΩ)
V _{OUT} ≤ 2.5V	100
V _{OUT} > 2.5V	50

About the C_L, please use more than 22 μF and B characteristic (JIS standard) or X7R, X5R (EIA standard). Please care about lack of capacitance and voltage-resistant when selecting the external components.

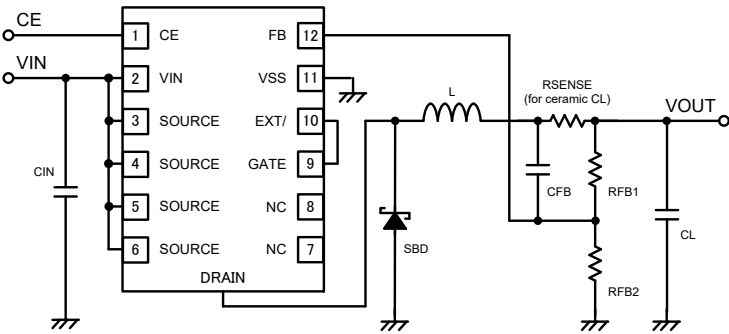

<External Components>

- SBD : CLS01(TOSHIBA)
- L : SLF10165T-4R7N4R73PF(4.7 μH, TDK / fosc=1.0MHz)
- RLF12545T-100M5R1(10 μH, TDK / fosc=500kHz)
- C_{IN} : 22 μF (EMK316BJ226ML/YUDEN)
- C_L : 22 μF or higher (LMK212BJ226MG/YUDEN fosc=1.0MHz)
- 47 μF or higher (LMK316BJ476ML/YUDEN fosc=500kHz)
- R_{SENSE} : 100mΩ (V_{OUT} ≤ 2.5V)
- 50mΩ (V_{OUT} > 2.5V)

● Selecting an inductor

Recommended inductance value of inductor by oscillation frequency is shown in the chart below.

f _{osc} (kHz)	L (μH)
500	10
1000	4.7

However, the more current change in each pulse becomes larger, the more output ripple voltage becomes higher when dropout voltage is high. This may lead to instability. In this case, increasing the inductance value will make I_{PK_AC} small, and it makes output stable.

$$I_{PK_AC} = (V_{IN} - V_{OUT}) \times V_{OUT} / (V_{IN} \times L \times f_{osc}) \dots \textcircled{3}$$

L: Inductance value
f_{osc}: Oscillation frequency

Please do not exceed the inductor rating. Inductor peak current is determined by the following equation.

$$I_{PK} = I_{OUT} + I_{PK_AC} / 2 \dots \textcircled{4}$$

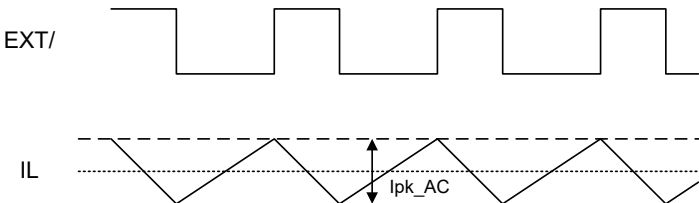

- I_{OUT} : Output Current
- I_L : Current flow through a coil
- I_{pk} : Peak Current
- I_{OUT} : I_{pk} - I_{pk_AC} / 2
- I_{pk_AC} : Amount of coil current change in each pulse

OPERATIONAL EXPLANATION

The XCM526 series consists of a reference voltage source, ramp wave circuit, error amplifier, PWM comparator, phase compensation circuit, protection circuits, UVLO circuit and others. The IC compares, using the error amplifier, the voltage of the internal voltage reference source with the feedback voltage from the V_{OUT} through split resistors. Phase compensation is performed on the resulting error amplifier output, to input a signal to the PWM comparator to determine the turn-on time during PWM operation. The PWM comparator compares, in terms of voltage level, the signal from the error amplifier with the ramp wave from the ramp wave circuit, and delivers the resulting output to the buffer driver circuit to cause the EXT pin to output a switching duty cycle. This process is continuously performed to ensure stable output voltage.

<XCM526xC Series>

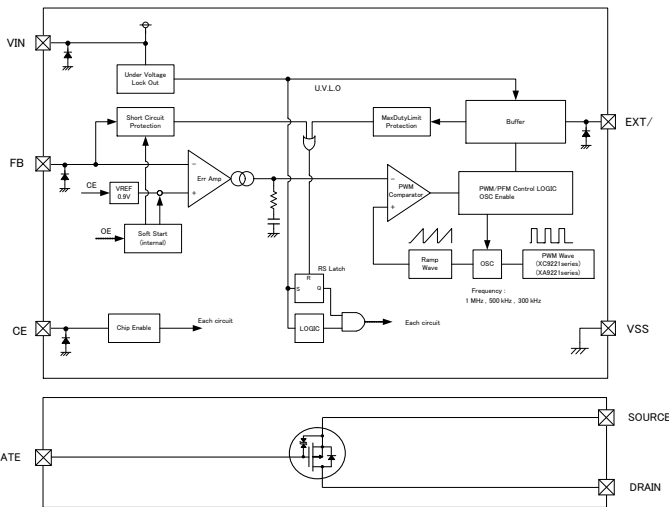

<XCM526xD Series>

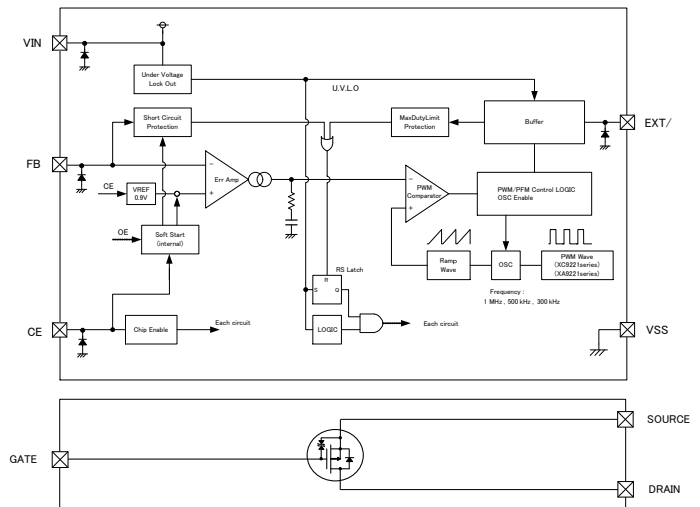

* Diodes inside the circuits are ESD protection diodes and parasitic diodes.

<Reference Voltage Source>

The reference voltage source provides the reference voltage to ensure stable output voltage of the DC/DC converter.

<Oscillator>

The oscillator determines switching frequency. The frequency is fixed internally and can be selected from 500kHz and 1.0MHz. Clock pulses generated in this circuit are used to produce ramp waveforms needed for PWM operation, and to synchronize all the internal circuits.

<Error Amplifier>

The error amplifier is designed to monitor output voltage. The amplifier compares the reference voltage with the feedback voltage (FB pin voltage) divided by the internal split resistors. When a voltage lower than the reference voltage is fed back, the output voltage of the error amplifier increases. The gain and frequency characteristics of the error amplifier output are fixed internally to deliver an optimized signal to the PWM comparator.

<Control Methods>

The XCM526A type is PWM control, and the XCM526B type is PWM/PFM automatic switching control. In the XCM526A type, it is controlled at a constant frequency from light load to heavy load. When a noise is concerned, it is easy to set up a filter. since the frequency is fixed. On the other hand, the efficiency at the time of light load may fall.

In the XCM526B type, the high efficiency can be drawn from PFM control at the time of light load. In PWM/PFM automatic switching mode, a control method is automatically changed from PWM control to PFM control at the time of light load. If inductor current becomes discontinuous at the time of light load, ON time duty intends to reduce less than 25%. Therefore, the PFM circuit operates to output the pulse, which ON time duty fixed to 25% from the EXT/pin. The ON time duty is fixed when PFM operation. The pulse is output with the cycle suitable for the conditions at that time. In order that the number of times of switching per unit time may decrease, the efficiency, which it is at the light load time is improved. However, pulse period cannot be fixed. For this, the circuit should be designed with considering this point when using a noise filter. The conditions shifting to the PFM operation depend on values of input voltage, load current, inductance and so on.

OPERATIONAL EXPLANATION (Continued)

<UVLO (Under Voltage Lock Out) >

When the input voltage falls below 2.3V (TYP.), the external P-channel driver transistor is forced OFF. Once the UVLO operates, the XCM526xC (soft-start internally fixed) resets the internal circuit. For this, by releasing the UVLO function, the IC performs the soft-start function to initiate output startup operation.

As for the XCM526xD (soft-start set externally), when the input voltage falls because of a power cutoff and the IC stops operation due to the UVLO function, the IC resumes its operation by internal soft-start circuit. If the soft-start time is needed to set externally, the CE/Css pin voltage should be reset to 0V. (Please see the soft-start circuit example.)

●UVLO Operation

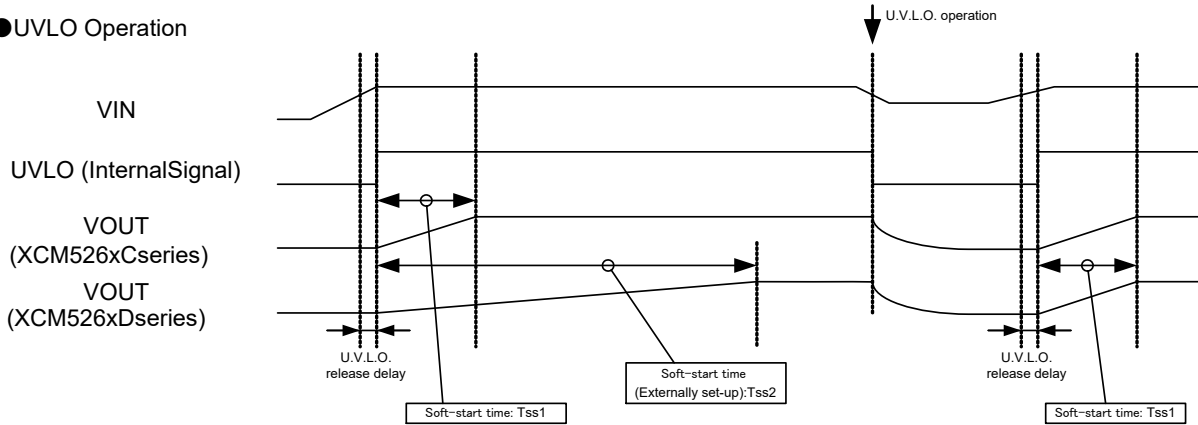

<Soft-Start Time>

The XCM526xD types can adjust the soft-start time externally via the CE pin. The soft-start function operates until the CE pin voltage becomes 2.6V. Please refer to the following equation for calculating the soft-start time. The soft-start time is depended on VCE, Rss and C_{SS}. Minimum soft-start time is equal to the time set internally.

$$t_{SS} = -C_{SS} \times R_{SS} \times \ln \left\{ \frac{V_{CE} - 2.2}{V_{CE}} \right\}$$

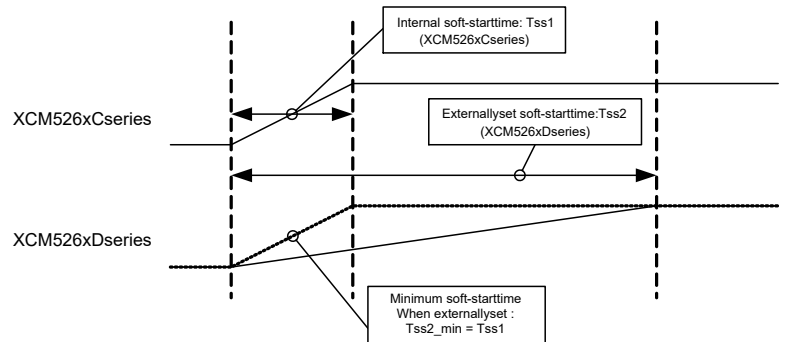
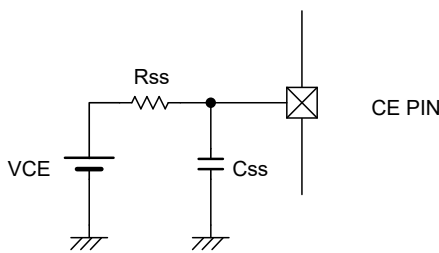

> Circuit Example1 : N-ch Open Drain

> Circuit Example2 : CMOS logic (low current dissipation)

> Circuit Example3 : CMOS logic (low current dissipation, quick off)

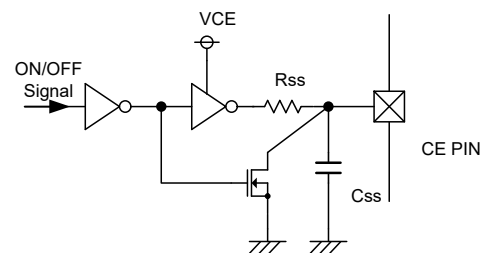
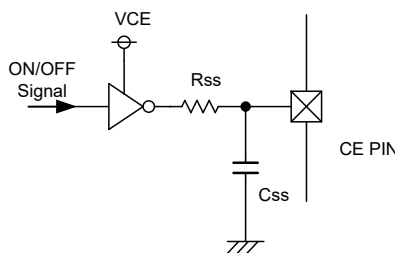
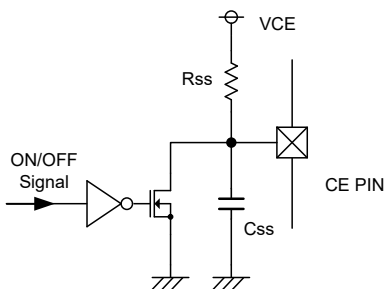

OPERATIONAL EXPLANATION (Continued)

<Protection Circuits>

● Short-Circuit Protection Circuit (Latching Type)

When the FB pin is shorted to Ground or the output voltage drops rapidly because of overload state, the P-ch driver transistor is kept OFF. (The protection circuit operates when the FB voltage becomes 0.7V or lower.) For releasing the latching state, the circuit is needed to restart via the VIN or the CE pin.

● Short-circuit protection circuit

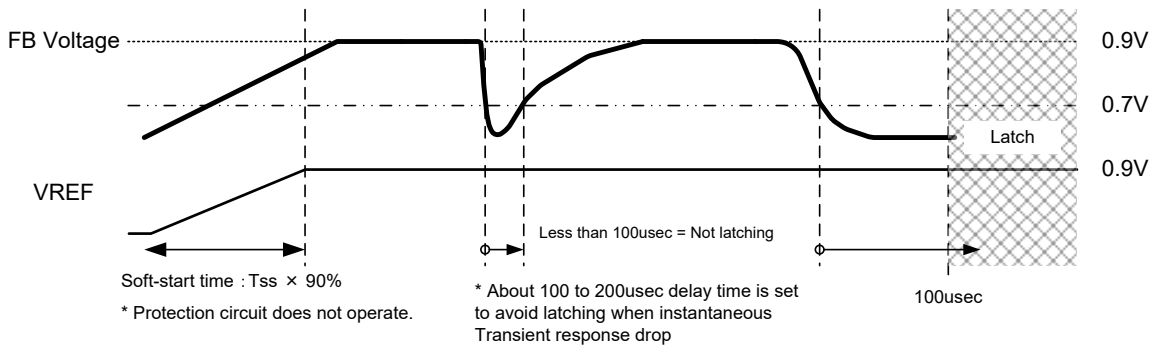

■ NOTES ON USE

1. For temporary, transitional voltage drop or voltage rising phenomenon, the IC is liable to malfunction should the ratings be exceeded.
2. The XCM526 series are designed for use with an output ceramic capacitor. If, however, the voltage difference between input and output is too large, a ceramic capacitor may fail to absorb the resulting high switching energy and oscillation could occur on the output. If the input-output voltage difference is large, connect the output capacitor with large performance to compensate for insufficient capacitance.
3. Spike noise and ripple voltage arise in a switching regulator as with a DC/DC converter. These are greatly influenced by external component selection, such as the inductance, capacitance values, and board layout of the external components. Once the design has been completed, verification with actual components should be done.
4. When the difference between input voltage and output voltage is large in PWM control, and the load current is light, very narrow pulses will be output, and there is the possibility that some cycles may be skipped completely.
5. When the difference between input voltage and output voltage is small in PWM control, and the load current is heavy, very wide pulses will be outputted and there is the possibility that some cycles may be skipped completely.
6. When using the CE pin by pulling up to the V_{IN} pin, please be noted to the rising speed of the V_{IN} pin voltage. If the rising time of the V_{IN} pin voltage is much slower than the soft-start time of the XCM526 series, the short-circuit protection starts to operate so that the output may not rise. When the V_{IN} pin voltage rises slow, please use a voltage detector or something similar to check that the input voltage rises fully. After that, the IC can be started by using the CE pin. Or we recommend the XCM526xD, adjusting the soft-start period externally so that the voltage at the V_{IN} pin rises fully before the soft-start period is completed.

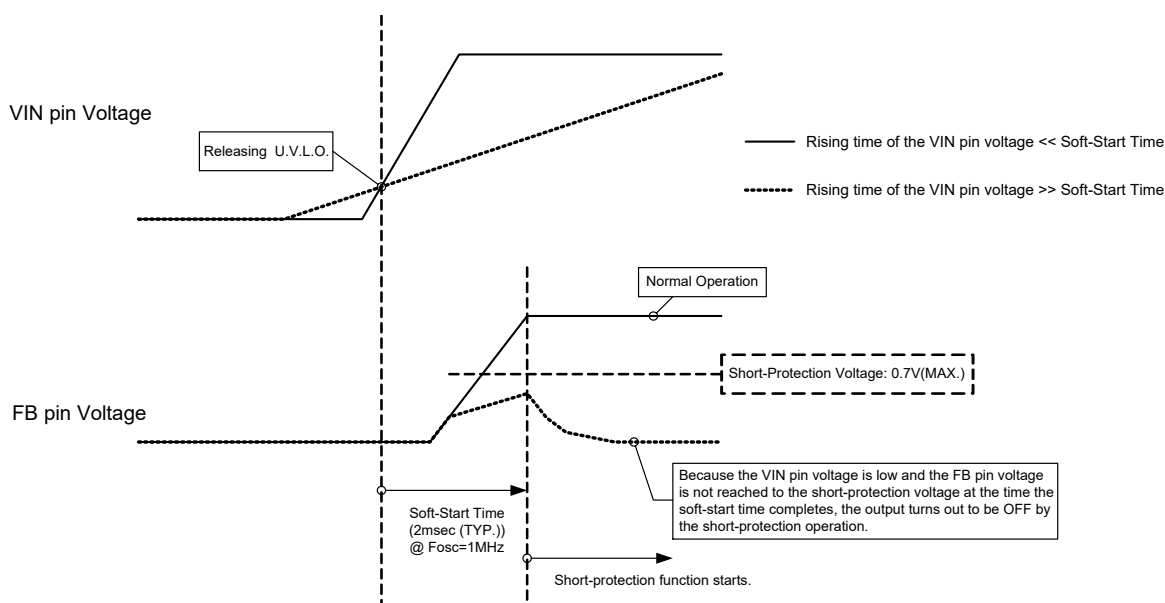

7. Use of the IC at voltages below the minimum operating voltage may lead to instability.
8. This IC and external components should be used within the stated absolute maximum ratings.
9. Please do not use the XCM526 as the only Power MOSFET.
10. Torex places an importance on improving our products and its reliability. However, by any possibility, we would request user fail-safe design and post-aging treatment on system or equipment.

NOTES ON USE (Continued)

● Instructions on Pattern Layout

- External components should be placed as close to the IC as possible and use thick, short connecting traces to reduce the circuit impedance.
- Please strengthen V_{IN} and V_{SS} wiring. Switching noise which occurs at the V_{IN} and GND may cause the instability of the IC.
For that matter, it is recommended to connect R_{IN} (about 10Ω) and C_{DD} (about $1\mu F$) to the V_{IN} pin if V_{IN} voltage is high and noise is high.
- All of SOURCE pins (No.3, 4, 5, and 6) for P-ch MOSFET should be connected.

● Recommended Pattern Layout

Front (Ceramic Capacitor use)

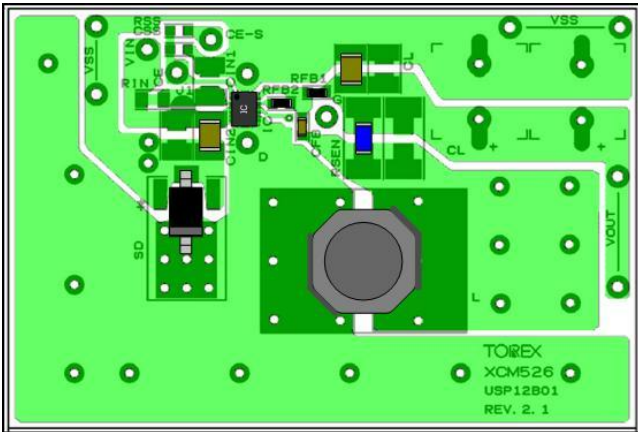

Front (OS Capacitor use)

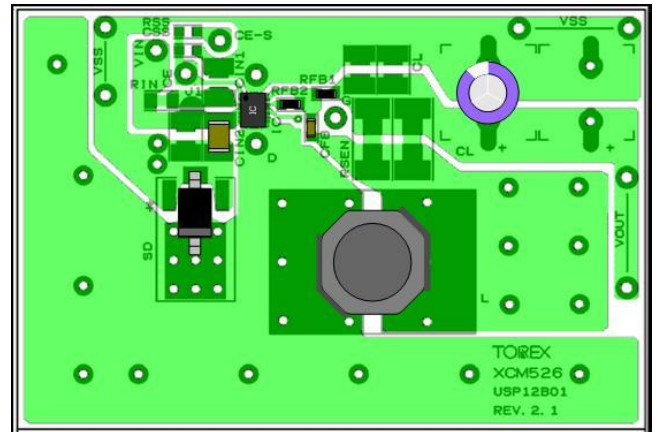

Front (Unmounted PCB)

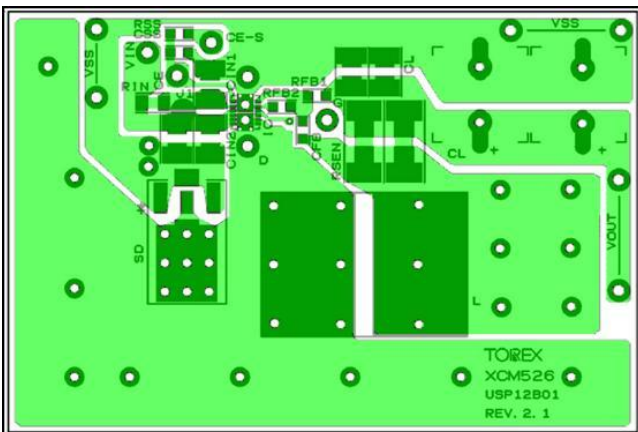

Back

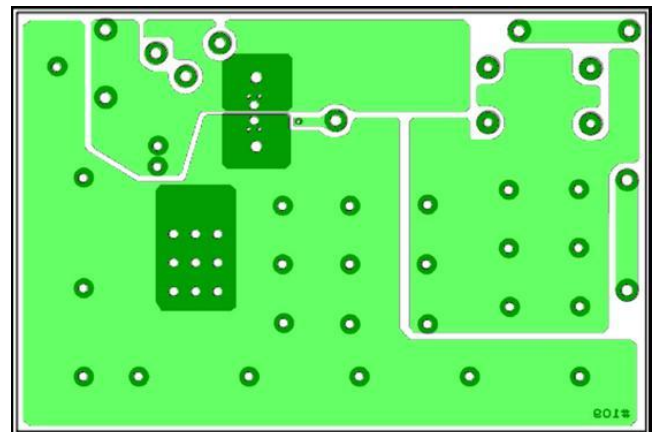

External Components



Inductor



Ceramic Capacitor



Inductor



Low Resistor



OS Capacitor



Resistor

TEST CIRCUITS

Circuit ①

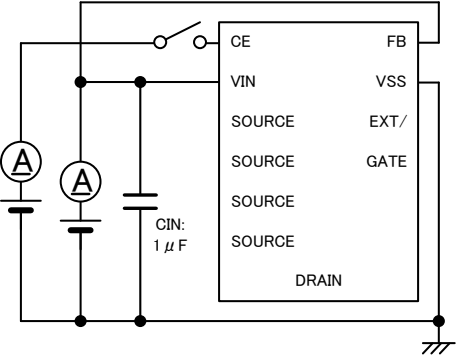

Circuit ②

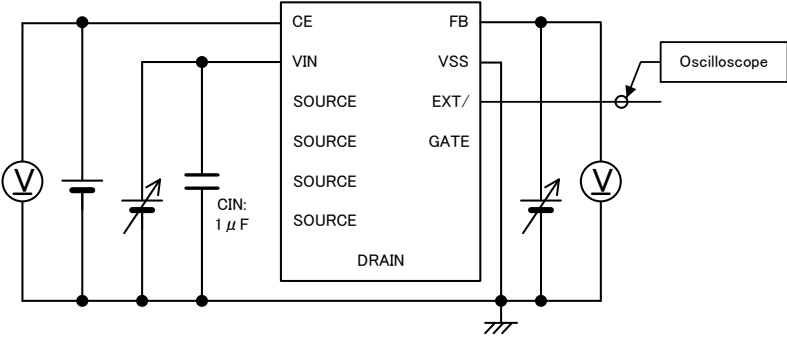

Circuit ③

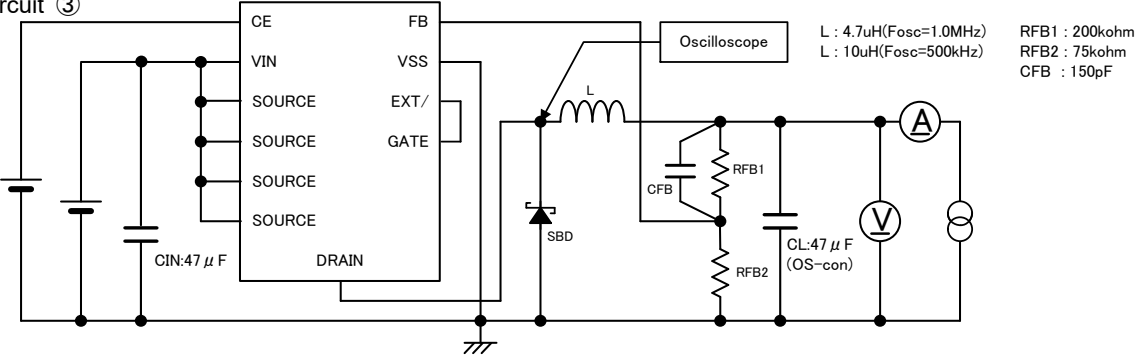

Circuit ④

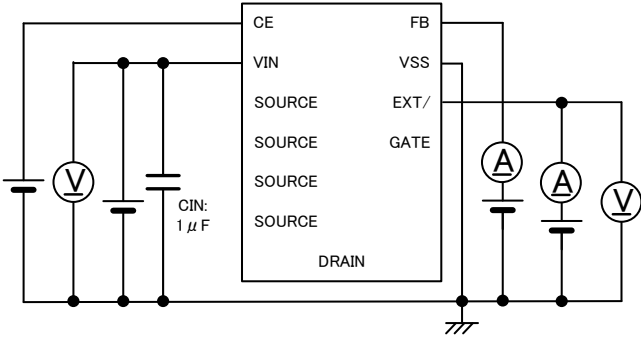

Circuit ⑤

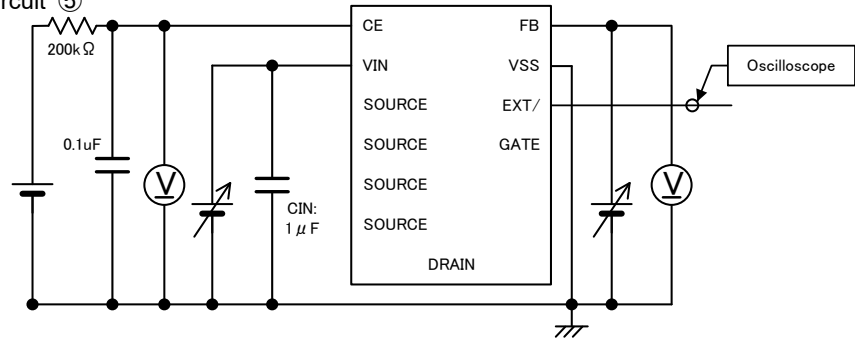

TEST CIRCUITS (Continued)

Circuit ⑥

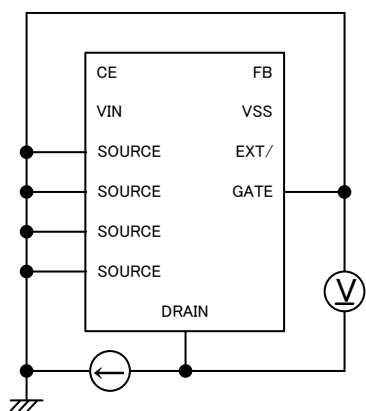

Circuit ⑦

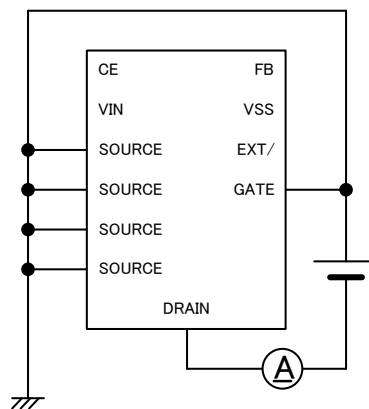

Circuit ⑧

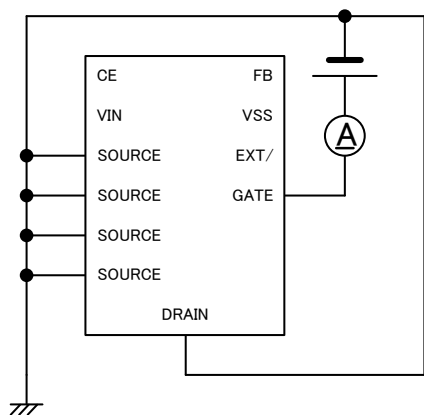

Circuit ⑨

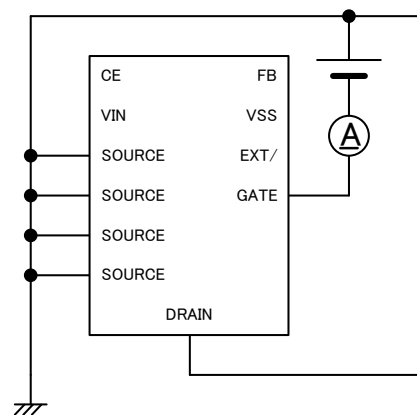

Circuit ⑩

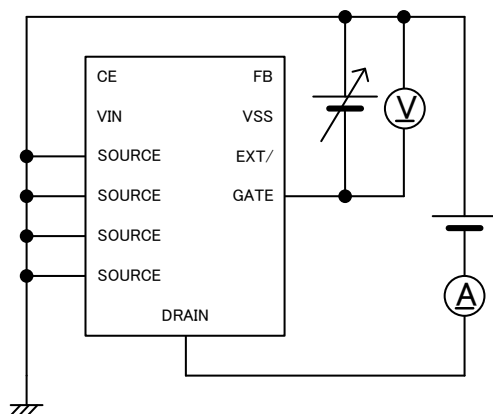

Circuit ⑪

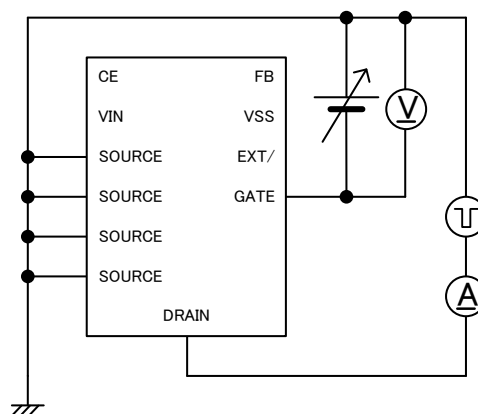

■ TEST CIRCUITS (Continued)

Circuit ⑫

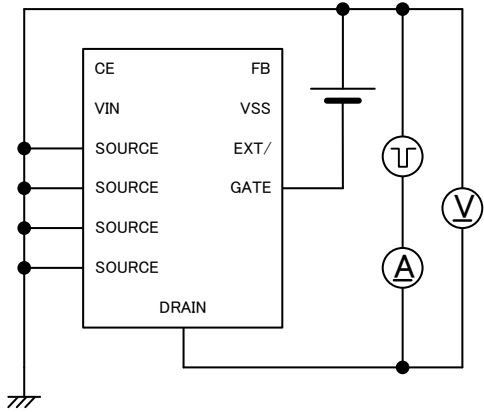

Circuit ⑬

⑬-1

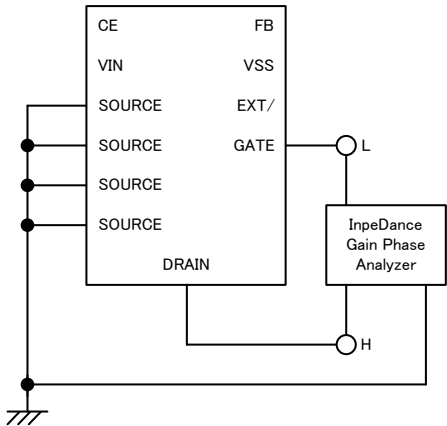

⑬-2

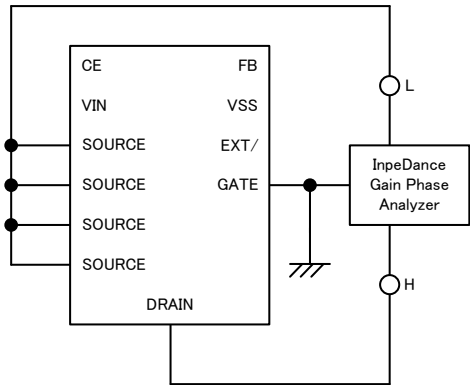

⑬-3

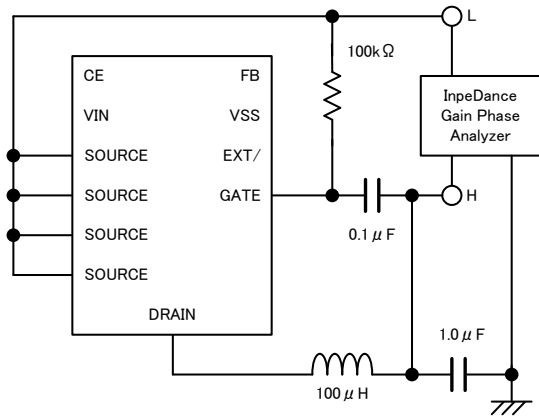

Input Capacitance: $C_{iss} = C_{gd} + C_{gs}$
 Output Capacitance: $C_{oss} = C_{ds} + C_{gd}$
 Feedback Capacitance: $C_{rss} = C_{gd}$

C_{gd} : Gate-Drain Capacitance (⑬-1)
 C_{ds} : Drain-Source Capacitance (⑬-2)
 C_{gs} : Gate-Source Capacitance (⑬-3)

TEST CIRCUITS (Continued)

Circuit ⑭

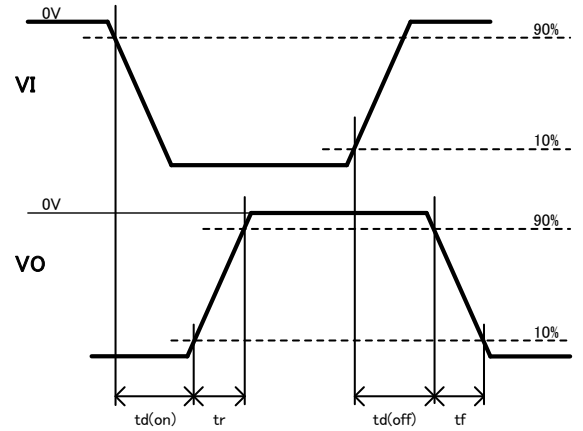
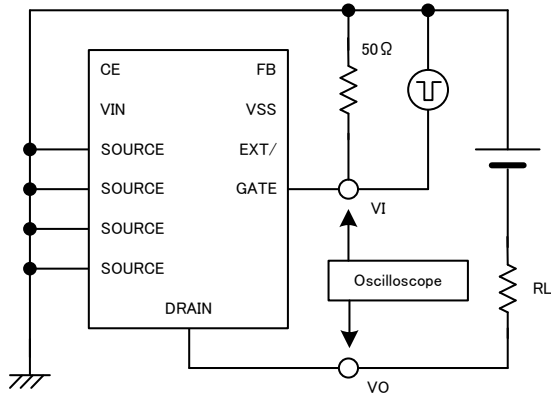

Circuit ⑮

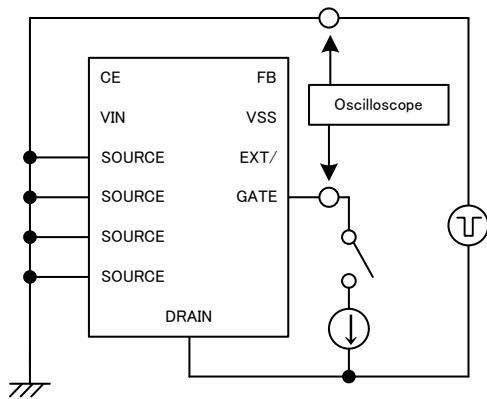

Circuit ⑯

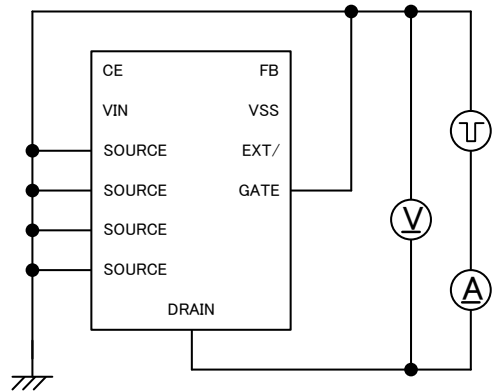

TYPICAL PERFORMANCE CHARACTERISTICS

(1) Efficiency vs. Output Current

XCM526Ax/Bx9Axx

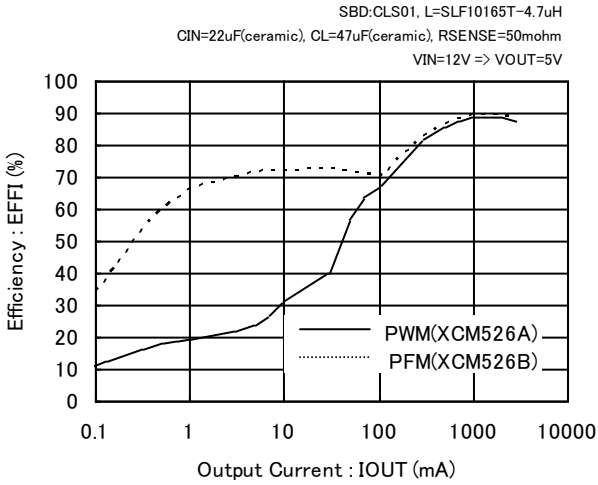

XCM526Ax/Bx9Axx

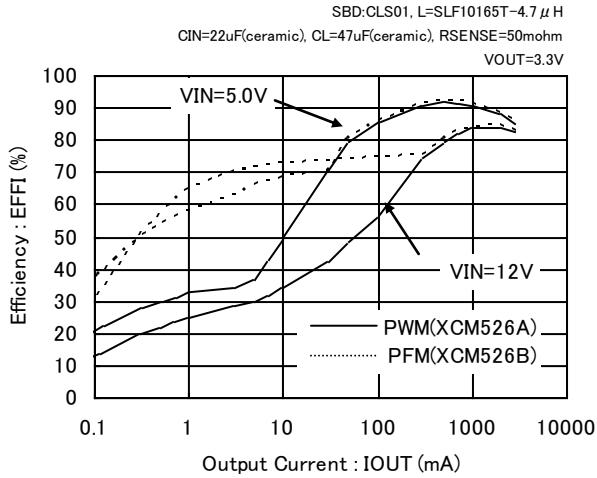

(2) Output Voltage vs. Output Current

XCM526Ax/Bx9Axx

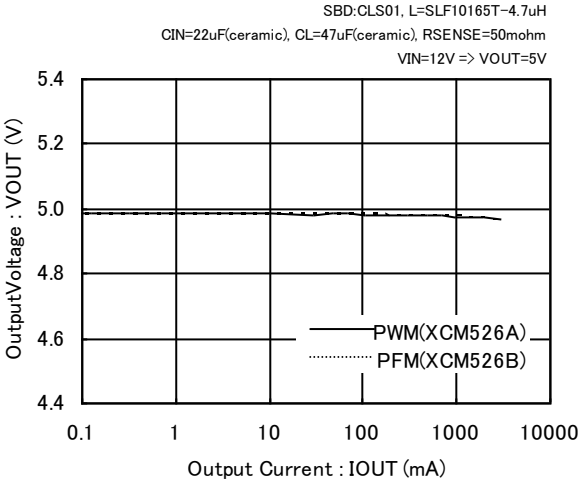

XCM526Ax/Bx9Axx

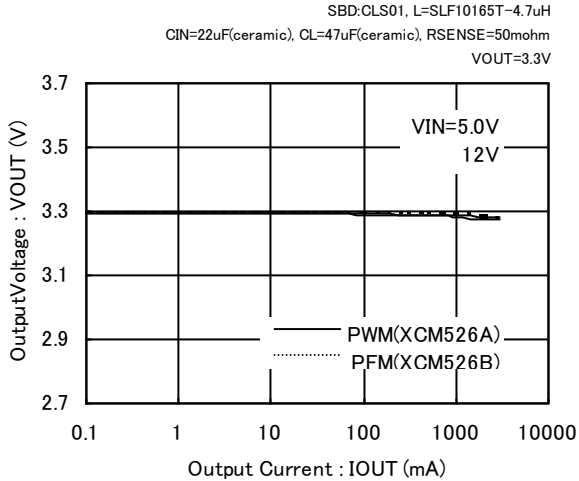

(3) Output Ripple Voltage vs. Output Current

XCM526Ax/Bx9Axx

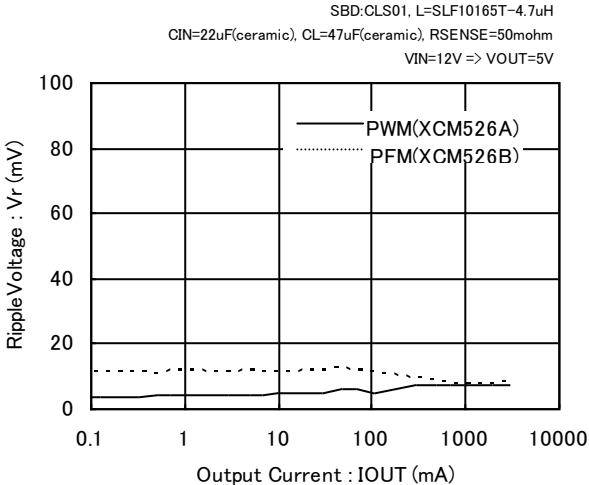

XCM526Ax/Bx9Axx

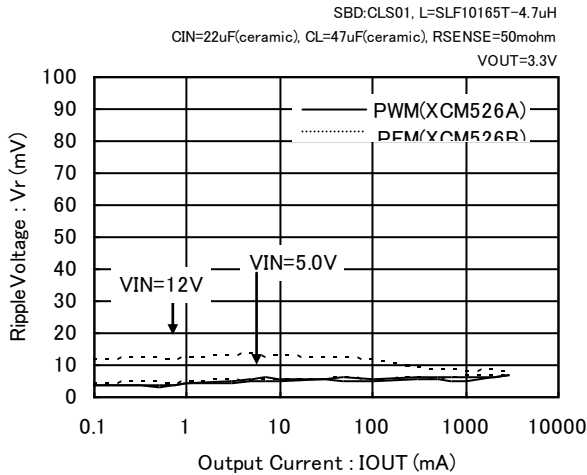

TYPICAL PERFORMANCE CHARACTERISTICS (Continued)

(4) FB Voltage Temperature Characteristics

XCM526series

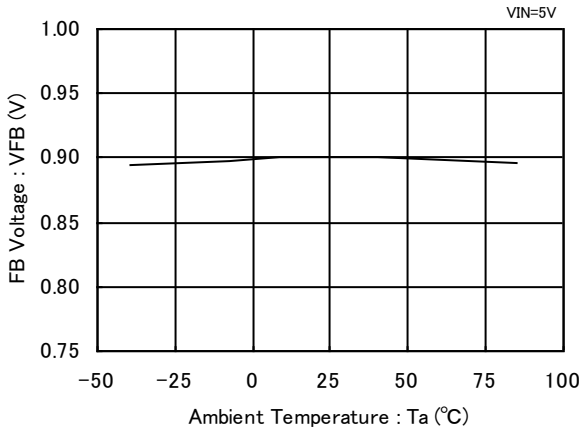

(5) FB Voltage vs. Input Voltage

XCM526series

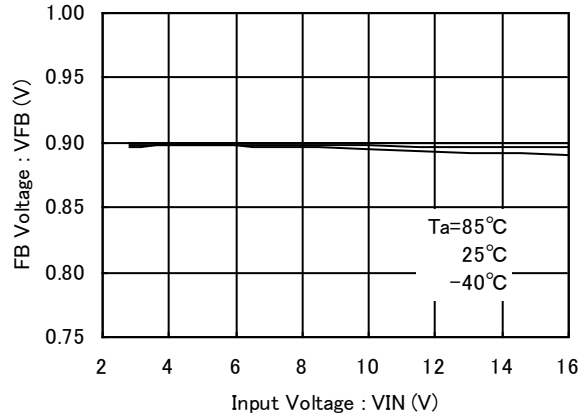

(6) Supply Current Temperature Characteristics

XCM526series

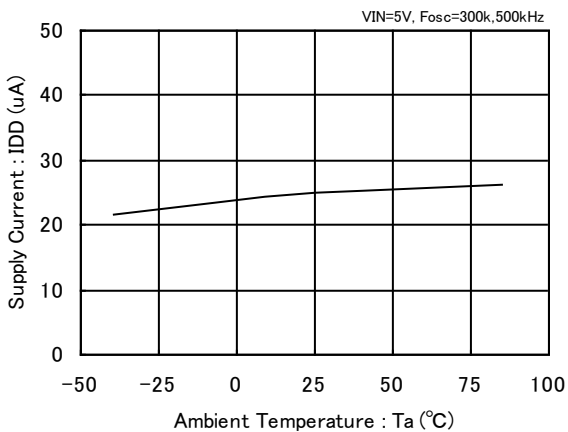

(7) Supply Current vs. Input Voltage

XCM526series

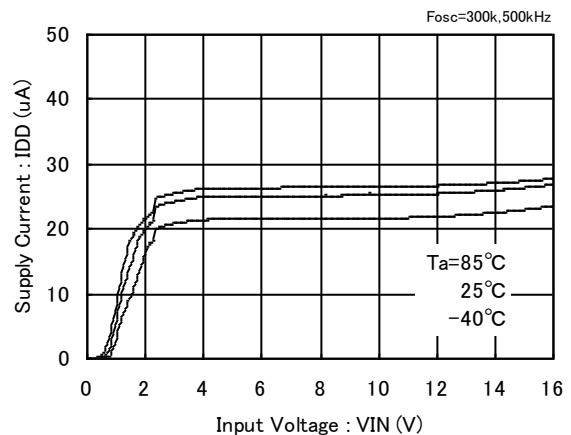

(8) Oscillation Frequency Temperature Characteristics

XCM526xx95xx

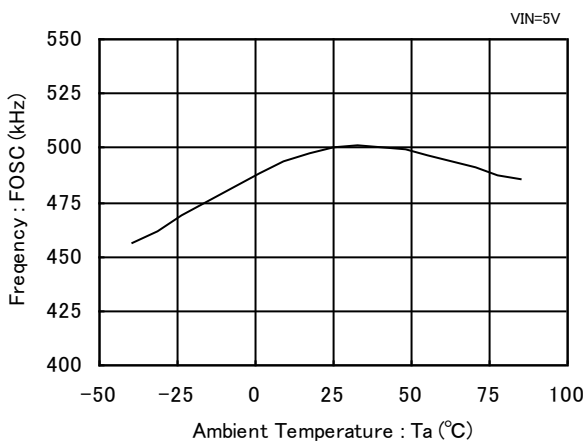

(9) UVLO Temperature Characteristics

XCM526series

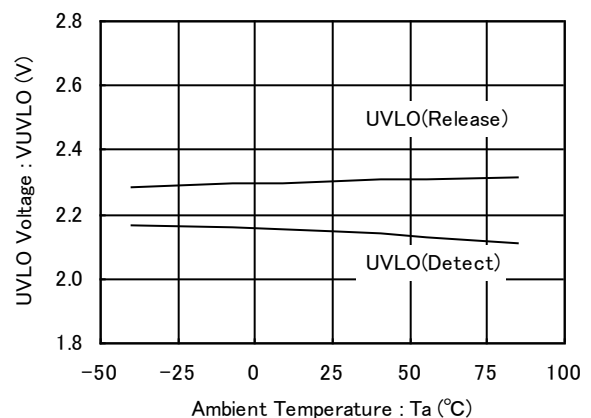

TYPICAL PERFORMANCE CHARACTERISTICS (Continued)

(10) EXT H ON Resistance Characteristics
XCM526series

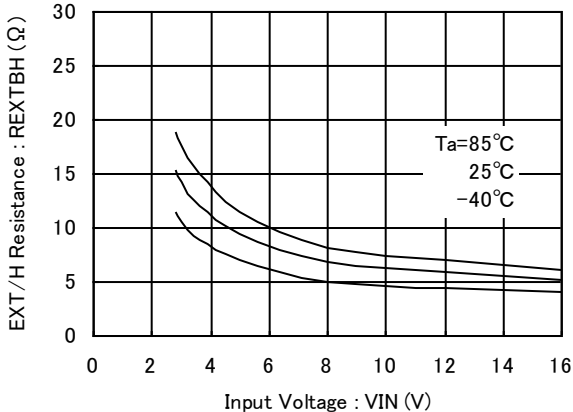

(11) EXT L ON Resistance Characteristics
XCM526series

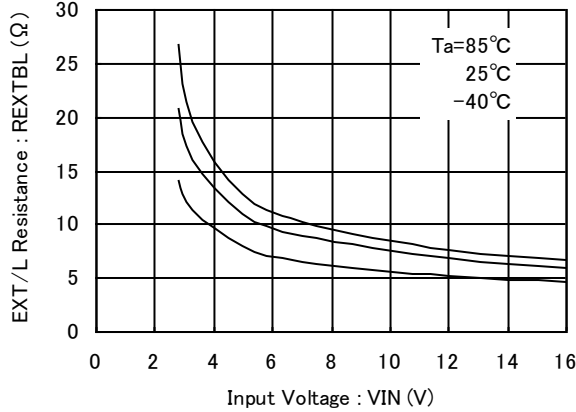

(12) Soft-Start Time Temperature Characteristics
XCM526series

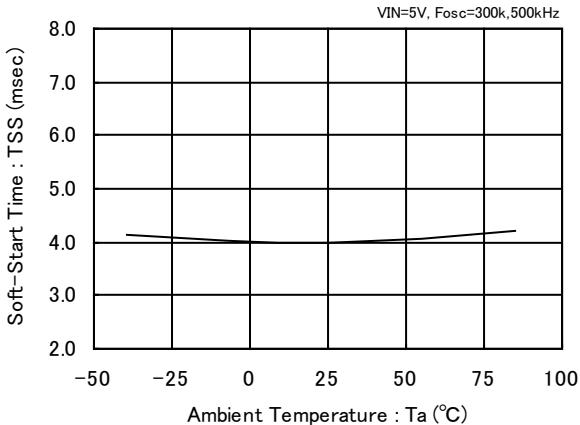

XCM526series

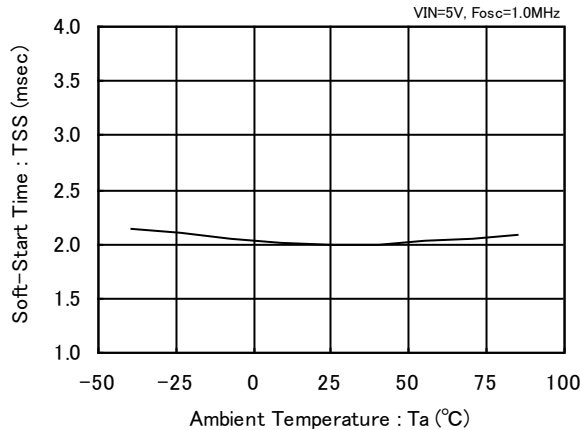

(13) Integral Protection Time Temperature Characteristics
XCM526series

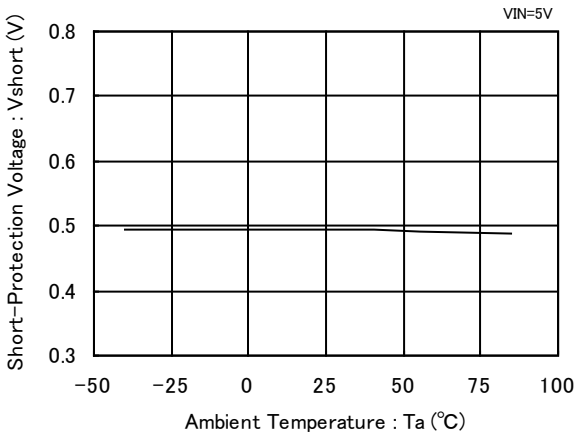

(14) Short-Circuit Protection Voltage vs. Input Voltage
XCM526series

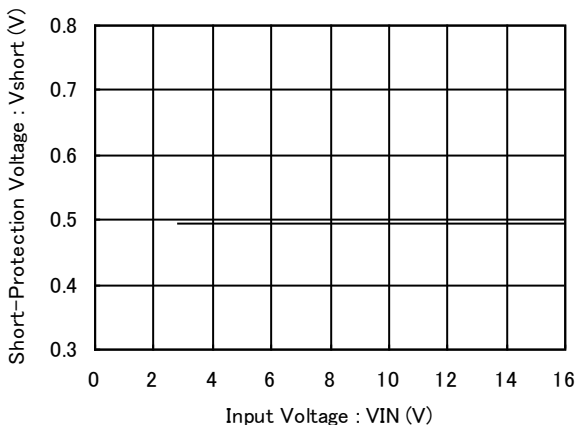

TYPICAL PERFORMANCE CHARACTERISTICS (Continued)

(15) CE Threshold Temperature Characteristics

XCM526series

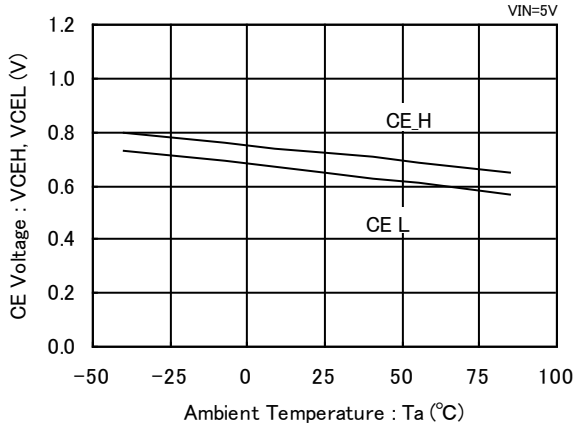

(16) CE Threshold vs. Input Voltage

XCM526series

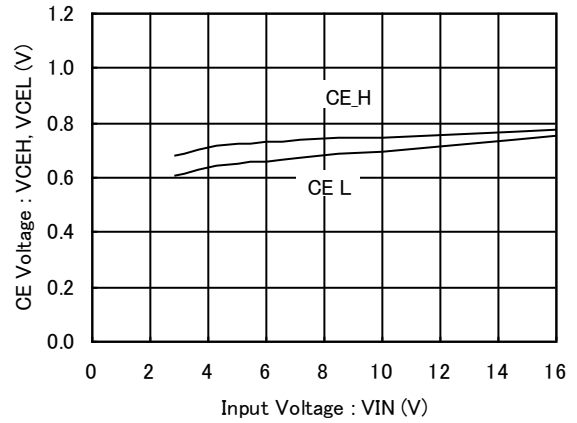

(17) Load Transient Response Characteristics

• IOUT: 0.1mA → 1000mA

XCM526Ax95xx

SBD: CLS01(TOSHIBA), L=10uH(RLF12545T, TDK)
CIN=47uF(ceramic), CL=47uF(OS-con)
VIN=5.0V, VOUT=3.3V

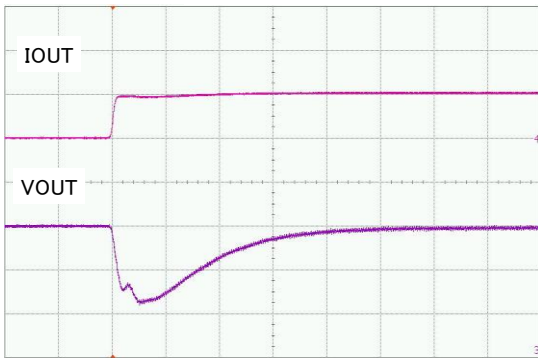

VOUT=100mV/div., Time=50µs/div.

XCM526Ax95xx

SBD: CLS01(TOSHIBA), L=10uH(RLF12545T, TDK)
CIN=47uF(ceramic), CL=47uF(OS-con)
VIN=5.0V, VOUT=3.3V

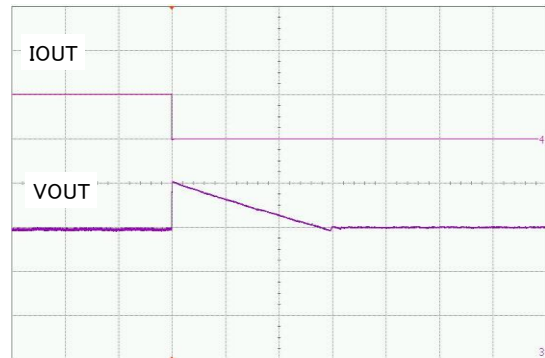

VOUT=100mV/div., Time=10ms/div.

• IOUT: 300mA → 3000mA

XCM526Ax95xx

SBD: CLS01(TOSHIBA), L=10uH(RLF12545T, TDK)
CIN=47uF(ceramic), CL=47uF(OS-con)
VIN=10.0V, VOUT=3.3V

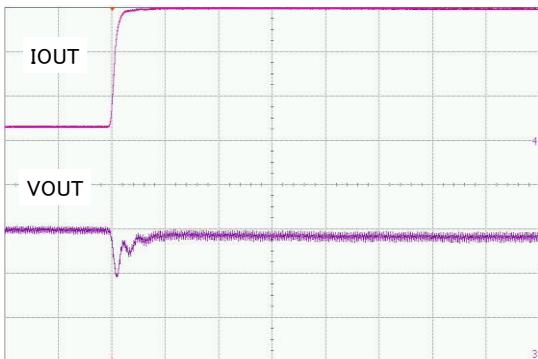

VOUT=100mV/div., Time=50µs/div.

XCM526Ax95xx

SBD: CLS01(TOSHIBA), L=10uH(RLF12545T, TDK)
CIN=47uF(ceramic), CL=47uF(OS-con)
VIN=10.0V, VOUT=3.3V

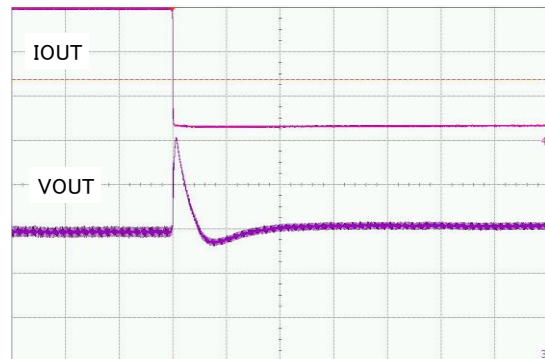

VOUT=100mV/div., Time=100ms/div.

TYPICAL CURVE CHARACTERISTICS

● P-ch POWER MOSFET

(1) Drain Current vs. Drain-Source Voltage

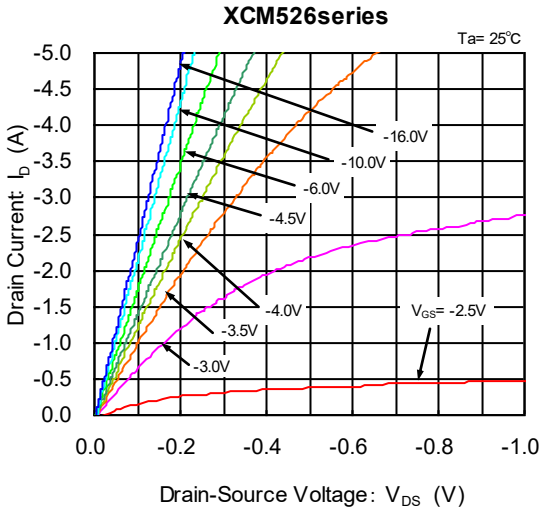

(2) Drain Current vs. Drain Source Voltage

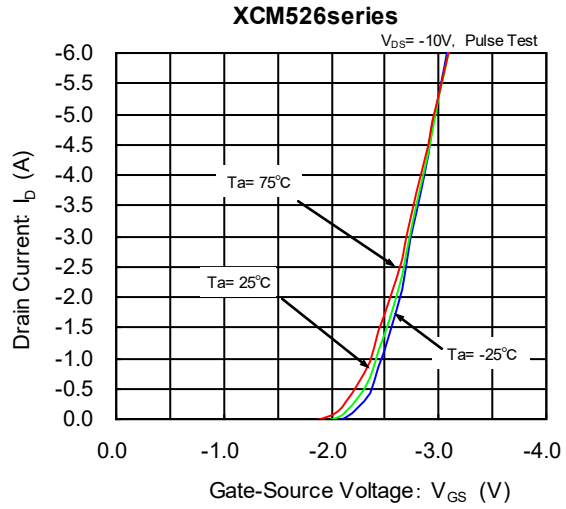

(3) Drain-Source On-State Resistance vs. Gate-Source Voltage

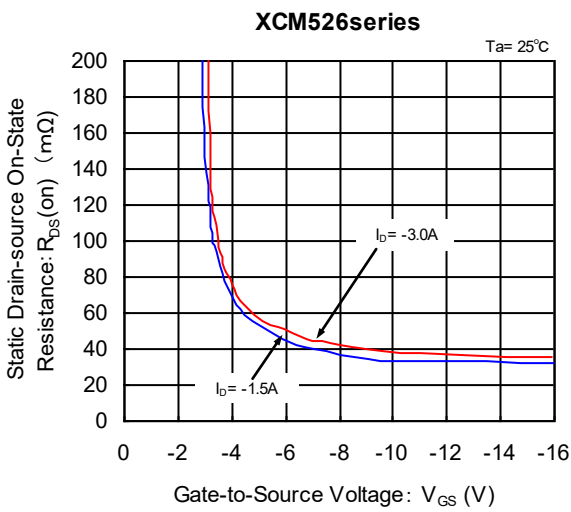

(4) Drain-Source On-State vs. Ambient Temperature

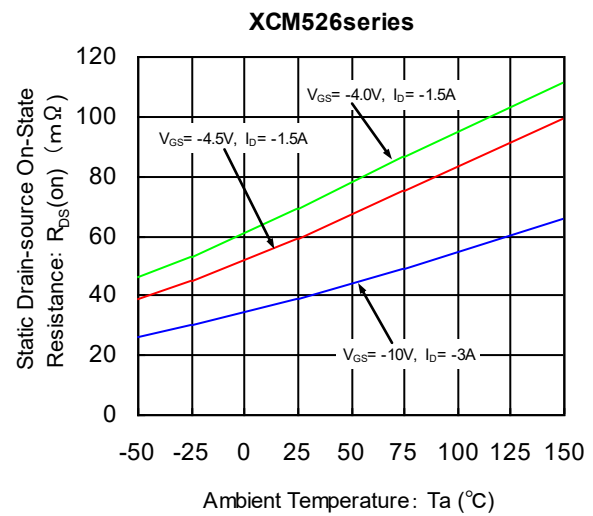

(5) Forward Transfer Admittance vs. Drain Current

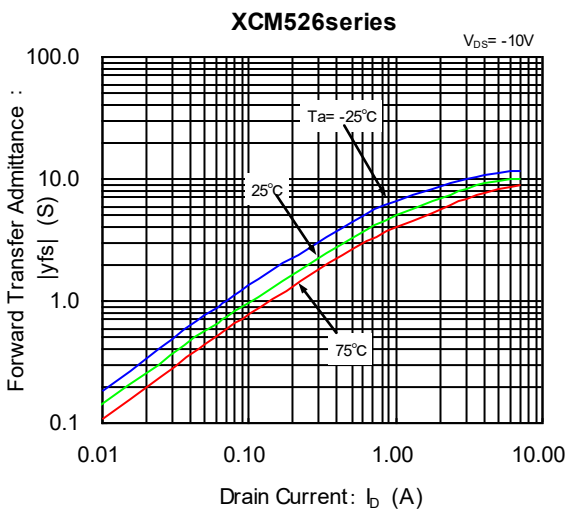

(6) Source Current vs. Diode Forward Voltage

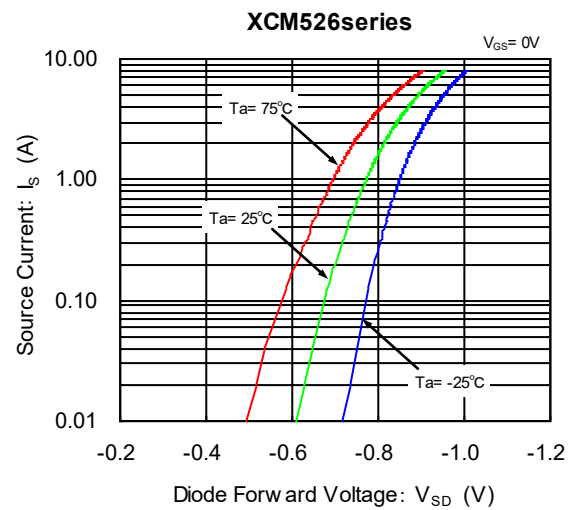

TYPICAL CURVE CHARACTERISTICS (Continued)

P-ch POWER MOSFET

(7) Switching Time vs. Drain Current

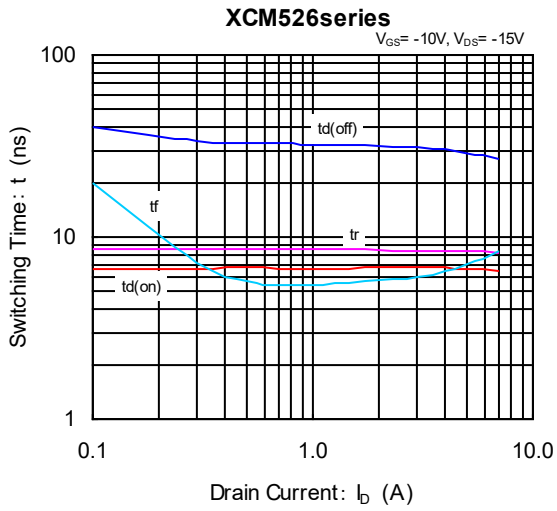

(8) Ciss, Coss, Crss vs. Drain-Source Voltage

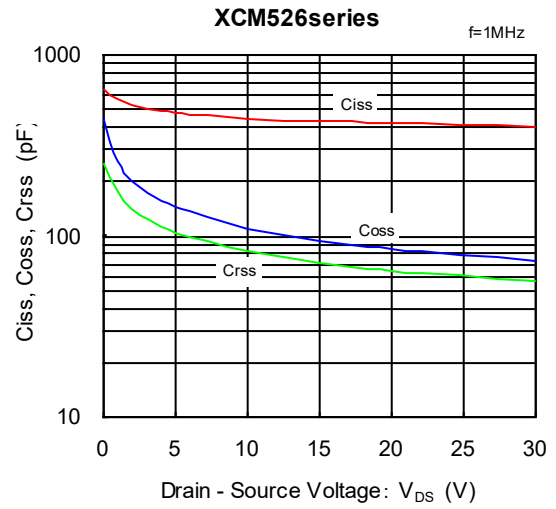

(9) Gate-Source Voltage vs. Gate Charge

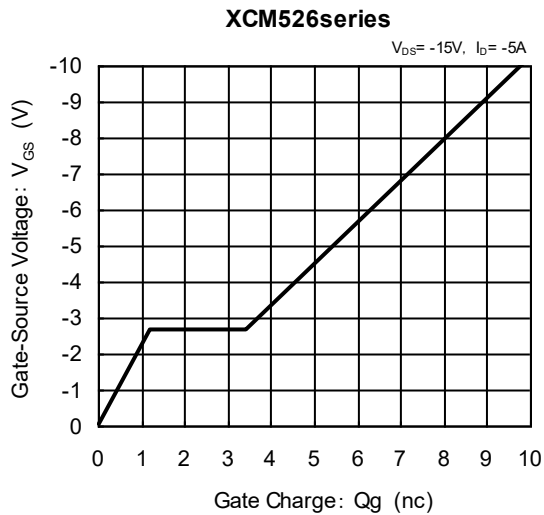

■ PACKAGING INFORMATION

For the latest package information go to, www.torexsemi.com/technical-support/packages

PACKAGE	OUTLINE / LAND PATTERN	THERMAL CHARACTERISTICS
USP-12B01	USP-12B01 PKG	USP-12B01 Power Dissipation

MARKING RULE

USP-12B01

● USP-12B01

① represents product series.

MARK	PRODUCT SERIES
3	XCM526****D*-G

②③ represents combination of the IC.

MARK		PRODUCT SERIES
②	③	
A	C	XCM526AC****D*-G

④ represents oscillation frequency.

MARK ④	PRODUCT SERIES
3	XCM526***3**-G
5	XCM526***5**-G
A	XCM526***A**-G

⑤⑥ represents production lot number

01 to 09, 0A to 0Z, 11 to 9Z, A1 to A9, AA to Z9, ZA to ZZ repeated. (G, I, J, O, Q, W excluded)

* No character inversion used.

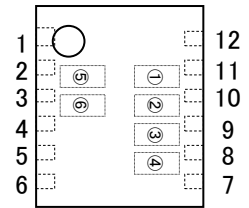

1. The product and product specifications contained herein are subject to change without notice to improve performance characteristics. Consult us, or our representatives before use, to confirm that the information in this datasheet is up to date.
2. The information in this datasheet is intended to illustrate the operation and characteristics of our products. We neither make warranties or representations with respect to the accuracy or completeness of the information contained in this datasheet nor grant any license to any intellectual property rights of ours or any third party concerning with the information in this datasheet.
3. Applicable export control laws and regulations should be complied and the procedures required by such laws and regulations should also be followed, when the product or any information contained in this datasheet is exported.
4. The product is neither intended nor warranted for use in equipment of systems which require extremely high levels of quality and/or reliability and/or a malfunction or failure which may cause loss of human life, bodily injury, serious property damage including but not limited to devices or equipment used in 1) nuclear facilities, 2) aerospace industry, 3) medical facilities, 4) automobile industry and other transportation industry and 5) safety devices and safety equipment to control combustions and explosions. Do not use the product for the above use unless agreed by us in writing in advance.
5. Although we make continuous efforts to improve the quality and reliability of our products; nevertheless Semiconductors are likely to fail with a certain probability. So in order to prevent personal injury and/or property damage resulting from such failure, customers are required to incorporate adequate safety measures in their designs, such as system fail safes, redundancy and fire prevention features.
6. Our products are not designed to be Radiation-resistant.
7. Please use the product listed in this datasheet within the specified ranges.
8. We assume no responsibility for damage or loss due to abnormal use.
9. All rights reserved. No part of this datasheet may be copied or reproduced unless agreed by Torex Semiconductor Ltd in writing in advance.

TOREX SEMICONDUCTOR LTD.