

**Li-ion/Li Polymer Battery Charger****AUR9801C****General Description**

The AUR9801C is a highly-integrated battery charger for single-cell Li-ion or Li-polymer batteries capable of operating with an input voltage reached 2.5V. It is a complete charger device designed to work with an USB port or 5V output AC adapter.

The AUR9801C operates with CC (constant current) mode and CV (constant voltage) mode profiles. A low-current preconditioning charge mode is also provided as a trickle charging operation. The charge current is programmable up to 1A with an external resistor or a logic input. The charge voltage is 1% accurate over the full application range.

When operating with a current-limited adapter, the charger minimizes the thermal dissipation with pulsed operations to prevent overheat conditions that is commonly occurred with conventional linear chargers. The AUR9801C reduces charge current for thermal fold-back to ensure product safe operation. The charger automatically re-charges the battery when the battery voltage drops blow a recharge threshold. The chip includes a safety timer for setting the fast charge time limit in case of charging a dead battery.

The AUR9801C is available in standard WDFN-3x3-10 package.

Features

- Complete Charger for Single-cell Li-ion Batteries
- Charges from either AC Adapter or USB Port
- Integrated Power Pass Device with Current Sensing
- No External Blocking Diode Required
- Pre-charge Condition with Safety Timing
- 1% Charger Voltage Accuracy
- Programmable Current Limit up to 1A
- Sleep Mode for Power Saving
- Charge Current Thermal Fold-back
- Stand-alone or Integrated Charger
- Ambient Temperature Range: -40°C to 85°C
- Thermally-enhanced WDFN-3x3-10 Package
- Pb-free Plus Anneal Available (RoHS Compliant)

Applications

- PDAs, Cell Phones and Smart Phones
- Digital Camera, MP3 and Handheld Gaming
- Portable Instruments Including Medical Handhelds
- Self-charging Battery Packs
- Stand-alone Chargers or USB Port Chargers

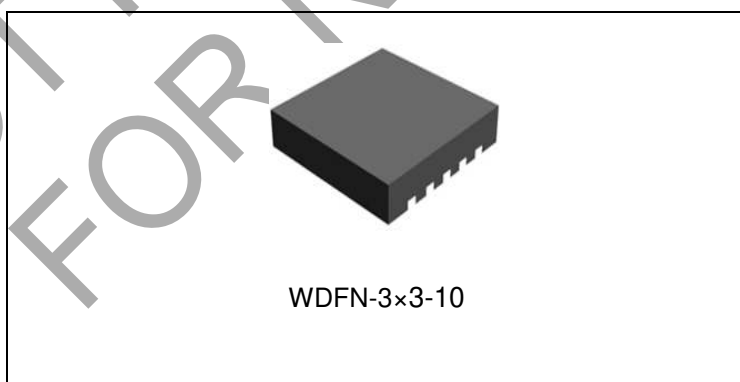

Figure 1. Package Type of AUR9801C

Li-ion/Li Polymer Battery Charger

AUR9801C

Pin Configuration

D Package
(WDFN-3×3-10)

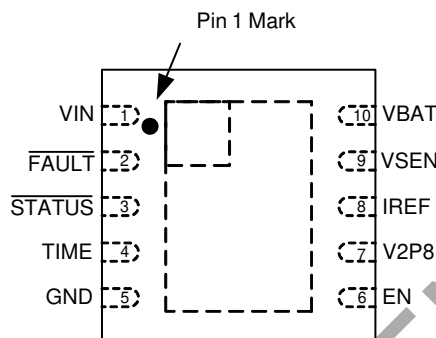

Figure 2. Pin Configuration of AUR9801C (Top View)

Pin Functions

Pin Number	Pin Name	Pin Type	Function
1	VIN	POWER	Charger input supply voltage
2	FAULT	O	Active-low, open-drain output, capable of sinking 5mA current
3	STATUS	O	Open-drain pin to show charging and inhibit states, capable of sinking 5mA current
4	TIME	I	Timing capacitor pin for connecting a capacitor to set internal clocking and charger time reference
5	GND	GROUND	Ground pin
6	EN	I	Chip enable control, high to activate the chip with internal 880KΩ pull-up resistor
7	V2P8	O	2.8V reference voltage output, capable of driving up to 2mA
8	IREF	I	A resistor can be connected at the pin to set the charge current
9	VSEN	I	VSEN is the remote voltage sense pin. Connect to battery positive node
10	VBAT	O	Connection to the battery positive node

Li-ion/Li Polymer Battery Charger

AUR9801C

Functional Block Diagram

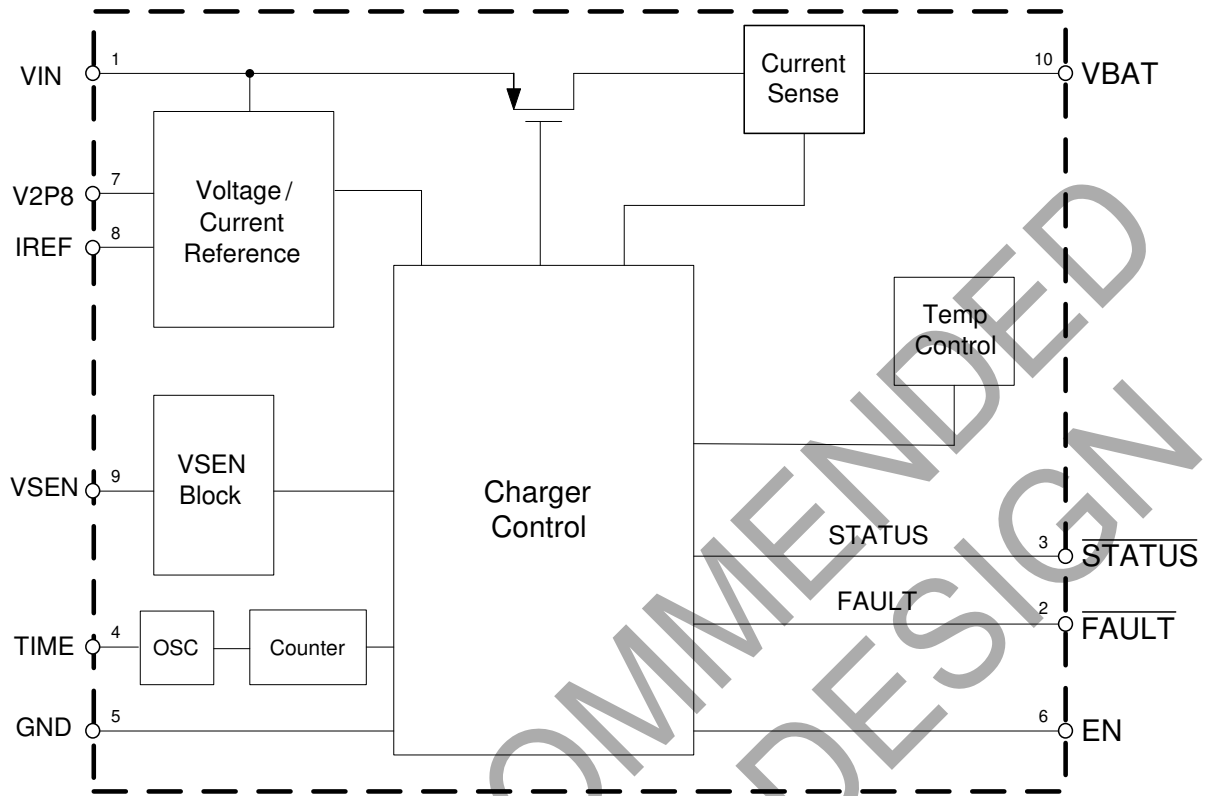
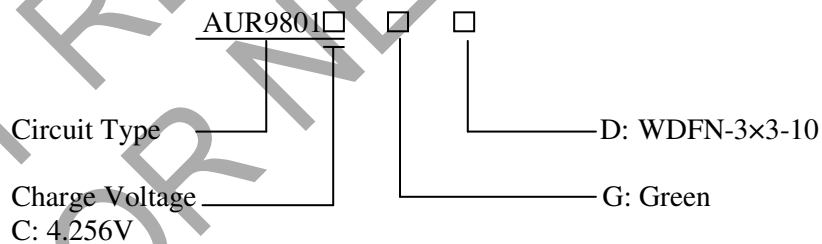

Figure 3. Functional Block Diagram of AUR9801C

Ordering Information



Package	Temperature Range	Part Number	Marking ID	Packing Type
WDFN-3x3-10	-40 to 85°C	AUR9801CGD	9801C	Type & Reel

BCD Semiconductor's Pb-free products, as designated with "G" suffix in the part number, are RoHS compliant and green.

**Li-ion/Li Polymer Battery Charger****AUR9801C****Absolute Maximum Ratings (Note 1)**

Parameter	Symbol	Value	Unit
Supply Input Voltage	V_{IN}	-0.3 to 6.5	V
Enable Input Voltage	V_{EN}	-0.3 to $V_{IN}+0.3$	V
Output Voltage	V_{BAT}	-0.3 to $V_{IN}+0.3$	V
Other Pin Voltage		-0.3 to $V_{IN}+0.3$	V
Thermal Resistance (Simulation)	θ_{JA}	45.13	°C/W
Operating Junction Temperature	T_J	160	°C
Storage Temperature	T_{STG}	-65 to 150	°C
ESD Withstand Voltage (Human Body Model)	V_{HBM}	2000	V
ESD Withstand Voltage (Machine Model)	V_{MM}	200	V

Note 1: Stresses greater than those listed under “Absolute Maximum Ratings” may cause permanent damage to the device. These are stress ratings only, and functional operation of the device at these or any other conditions beyond those indicated under “Recommended Operating Conditions” is not implied. Exposure to “Absolute Maximum Ratings” for extended periods may affect device reliability.

Recommended Operating Conditions

Parameter	Symbol	Min	Max	Unit
Supply Voltage	V_{IN}	4.6	5.5	V
Ambient Temperature Range	T_A	-40	85	°C

**Li-ion/Li Polymer Battery Charger****AUR9801C****Electrical Characteristics**

$V_{IN}=5V$ and $T_A=25^{\circ}C$ for the typical values. The maximum and minimum values are over $-40^{\circ}C$ to $85^{\circ}C$ Ambient Temperature with a supply voltage in the range of 4.6V to 5.5V, unless otherwise specified.

Parameter	Symbol	Conditions	Min	Typ	Max	Units
Power-on Reset						
VIN Rising Voltage			3.2	3.6	3.9	V
VIN Falling Voltage			2.25	2.5	2.7	V
Standby Current						
VBAT Pin Sink Current	$I_{STANDBY}$	VIN floating or EN=LOW			3.3	μA
VIN Pin Supply Current	I_{IN}	VBAT floating and EN pulled low		150		μA
		VBAT floating and EN floating			1	mA
VIN-VBAT Offset Voltage						
Offset Voltage	V_{OS}	$V_{BAT}=4.2V$, $I_{BAT}=20mA$, use /STATUS pin	45	80	100	mV
Voltage Regulation						
Output Voltage	V_{BAT}	Tested at 50mA load, 5V input, and $25^{\circ}C$	4.213	4.256	4.299	V
Dropout Voltage		$V_{BAT}=4.0V$, Charge Current=0.35A		175		mV
Charge Current						
Constant Charge Current	I_{CHG}	$R_{IREF}=100k\Omega$, $V_{BAT}=3.0V$ to $4.0V$	760	800	840	mA
Trickle Charge Current	$I_{TRICKLE}$	$R_{IREF}=100k\Omega$, $V_{BAT}=2.5V$		120		mA
End-of-Charge Threshold	I_{MIN}	$R_{IREF}=100k\Omega$	70	80	90	mA
V2P8 Pin Output						
V2P8 Pin Output Voltage	V_{2P8}	Load current less than 1mA	2.8	2.9	3.0	V
Recharge Threshold						
Recharge Threshold	V_{RECHG}		3.97	4.05	4.13	V
Recharge Threshold Hysteresis	$V_{RECHGHS}$			50		mV
Trickle Charge Threshold						
Trickle Threshold Voltage	V_{MIN}		2.7	2.8	2.9	V
Trickle Threshold Hysteresis	V_{MINHYS}		50	100	150	mV

**Li-ion/Li Polymer Battery Charger****AUR9801C****Electrical Characteristics(Continued)**

$V_{IN}=5V$ and $T_A=25^{\circ}C$ for the typical values. The maximum and minimum values are over $-40^{\circ}C$ to $85^{\circ}C$ Ambient Temperature with a supply voltage in the range of 4.6V to 5.5V, unless otherwise specified.

Parameter	Symbol	Conditions	Min	Typ	Max	Units
Temperature Monitoring						
Fold-back Threshold	T_{FOLD}			107		$^{\circ}C$
Oscillator						
Oscillation Frequency	f_{OSC}	$C_{TIME}=15nF$	305	333	370	Hz
Logic Input and Output						
EN Pin Logic Input High			1.5			V
EN Pin Logic Input Low					0.8	V
EN Pin Internal Pull-up Resistance				880		$k\Omega$
/STATUS, /FAULT Output Voltage		10mA Current			0.8	V



Li-ion/Li Polymer Battery Charger

AUR9801C

Typical Performance Characteristics

$V_{IN}=5V$, $T_A=25^{\circ}C$, $R_{IREF}=100k\Omega$, $V_{BAT}=3.7V$, unless otherwise specified.

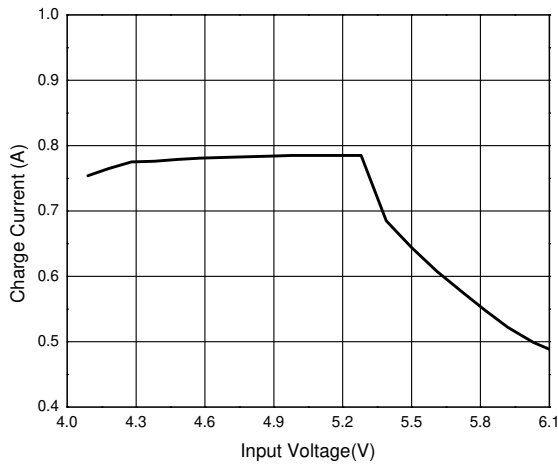

Figure 4. Charge Current vs. Input Voltage

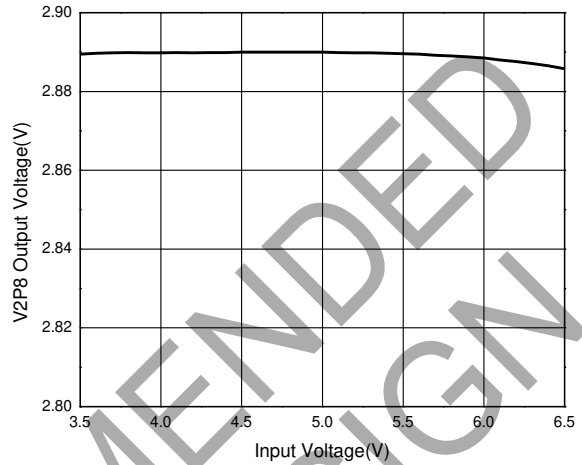

Figure 5. V2P8 Output Voltage vs. Input Voltage

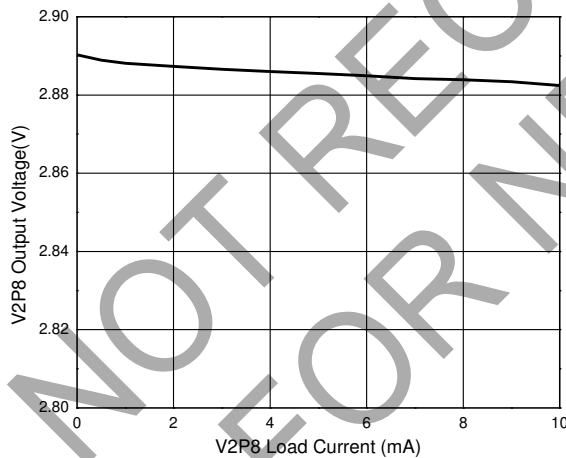

Figure 6. V2P8 Output Voltage vs. V2P8 Load Current



Li-ion/Li Polymer Battery Charger

AUR9801C

Description of Charger Operation

The AUR9801C initiates a charger operation when attached with a voltage source device or adaptor. Figure 7 shows a typical charge profile when the chip operates as a conventional linear charger with a constant voltage source. The charging current is set by an external resistor up to 1A. The target charging voltage is 1% accurate over the specified range.

The charger IC resets internal operational circuits when internal Power-on-reset (POR) signal becomes valid. V2P8 presents a voltage reference output source capable of driving 2mA current after POR. Other indication output pins are /STATUS

and /FAULT. The /STATUS is active low as an open-drain type to indicate a charging cycle and valid till the End-off-charge (EOC). The /FAULT output signal becomes low to signal any occurred fault conditions such as a charging time fault.

When charge with a current-limited adapter, AUR9801C should be programmed with I_{REF} over the upper limit of I_{LIM} . A typical charge profile is displayed in Figure 8 for minimizing power dissipation during CC mode. The worst power dissipation is often at the start of CV mode, although thermal fold-back conditions could still occur in this application case.

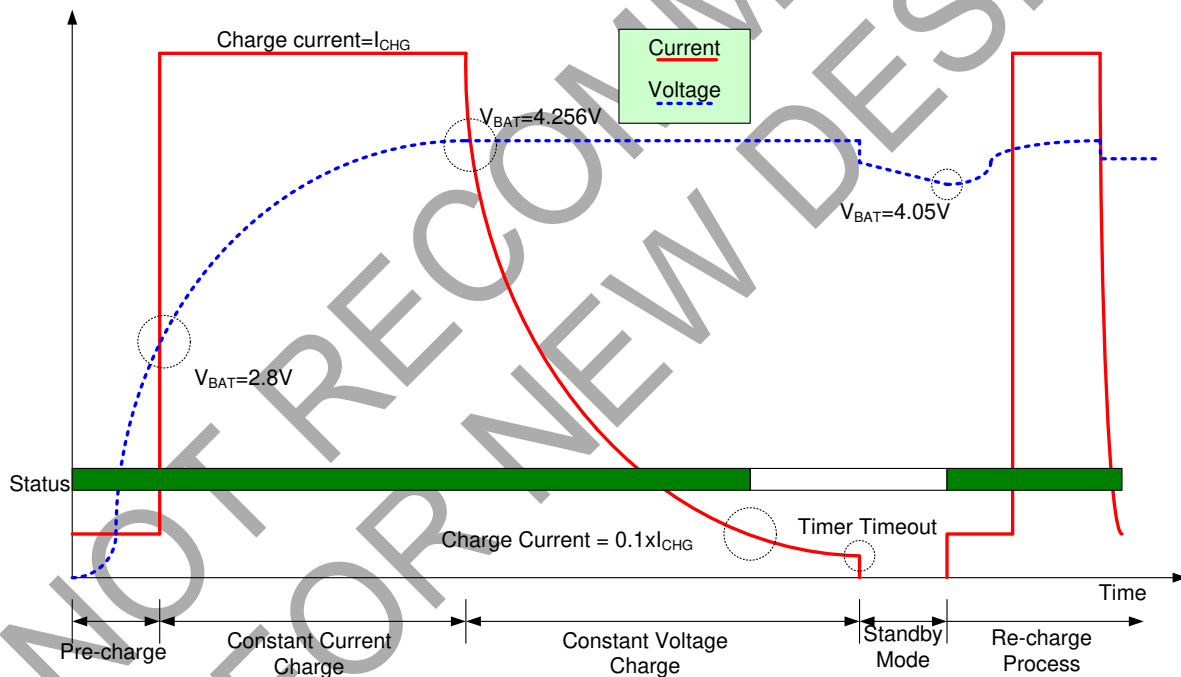

Figure 7. A Typical Charge Profile as a Conventional Linear Charger



Li-ion/Li Polymer Battery Charger

AUR9801C

Description of Charger Operation (Continued)

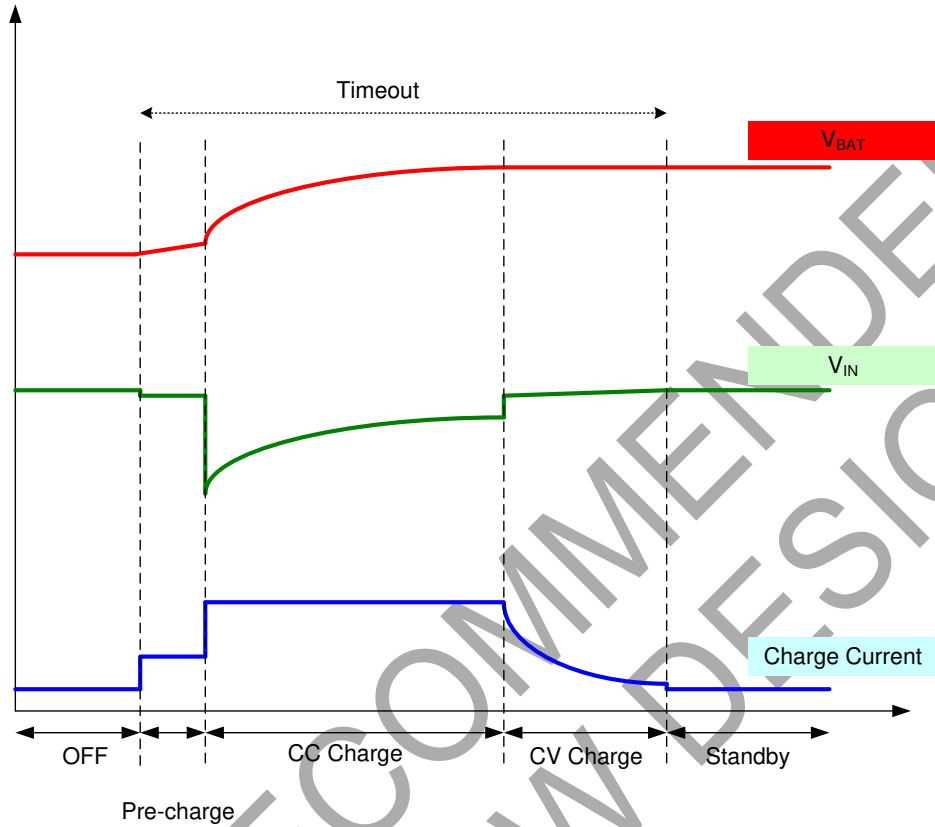

Figure 8. A Typical Charge Profile with a Current-limited Adapter



Li-ion/Li Polymer Battery Charger

AUR9801C

Operation Overview

For linear charging case, the AUR9801C performs either constant current (CC) and constant voltage (CV) profiles. The charging current is set by an external resistor up to 1A for package options. The target charging voltage is 1% accurate over the specified range. AUR9801C enters a trickle mode for preconditioning operation each time when a charging cycle starts till that the minimum charging voltage is reached and verified in 15 clock cycles.

A thermal-feedback function offers thermal protection during linear charging operations. When the die temperature of AUR9801C goes up above 107 degree C, the charger automatically reduces the charging current.

AUR9801C provides a TIMEOUT limit to prevent charging a dead battery for extensive time. Recharging is automatically started when battery voltage drops to the recharging threshold point. AUR9801C enters the shutdown mode in case no voltage adapter is attached.

/STATUS	/FAULT	Condition
High	High	Power-down, charging is suspended or interrupted
Low	High	Charging
High	Low	Bad battery (Safety timer expired)

Charge current setting

$$I_{CHG} = 0.8 \times \left(\frac{10^5}{R_{REF}} \right) \text{ Where } R_{REF} \text{ in } K\Omega$$

Charge timer setting

$$Time = 14 \times \frac{C_{time}}{1nF} \text{ Where } Time \text{ in Minutes}$$

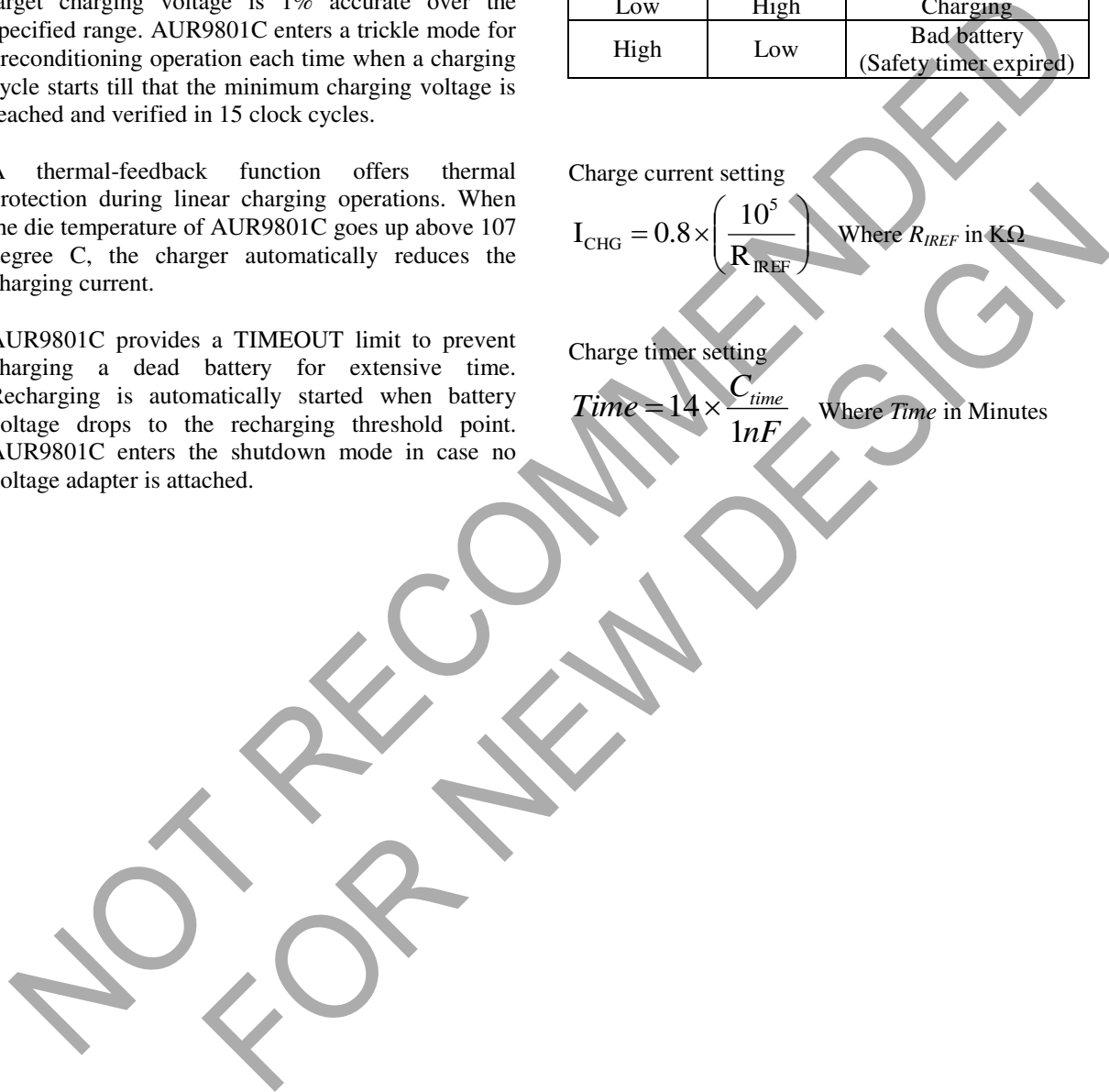



Li-ion/Li Polymer Battery Charger

AUR9801C

Flow chart

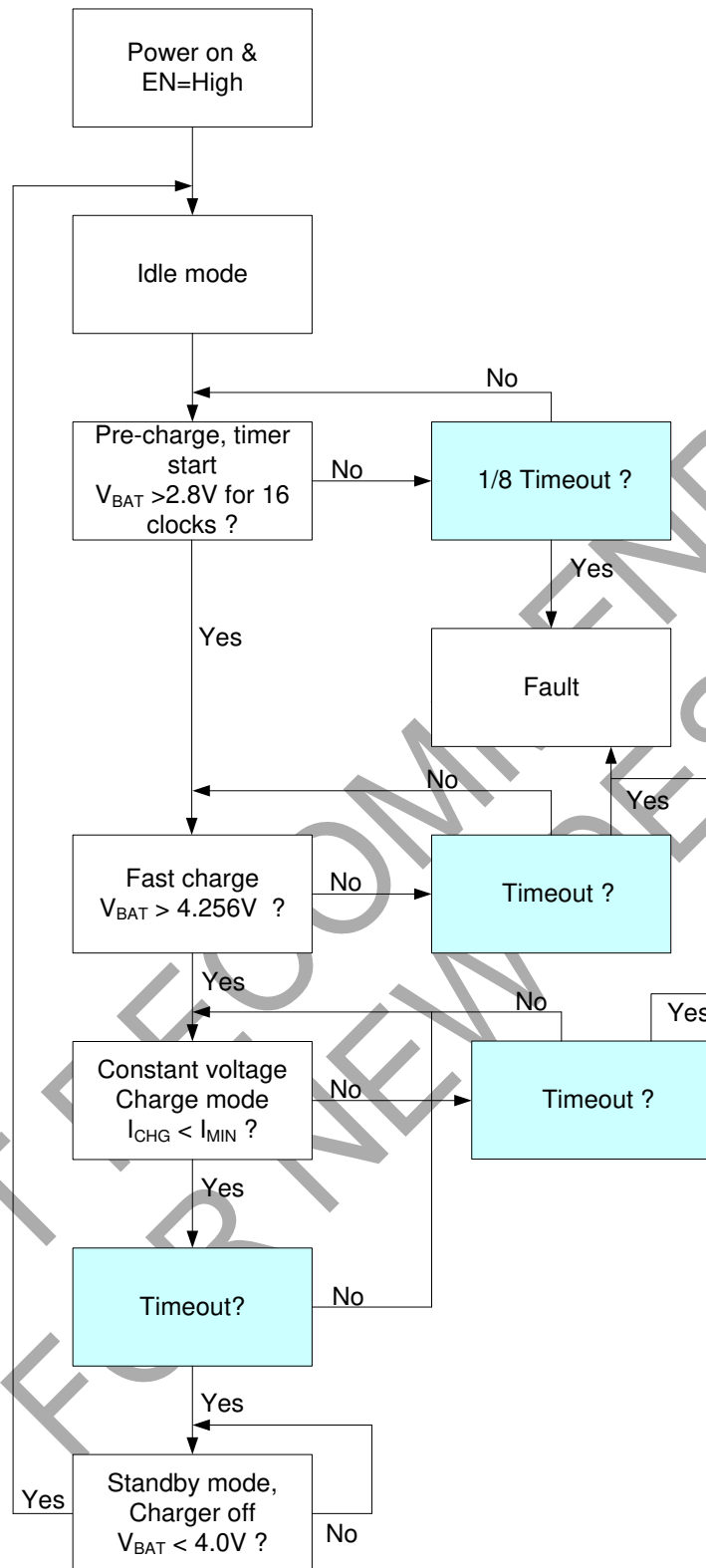

Li-ion/Li Polymer Battery Charger **AUR9801C**

Application Circuit

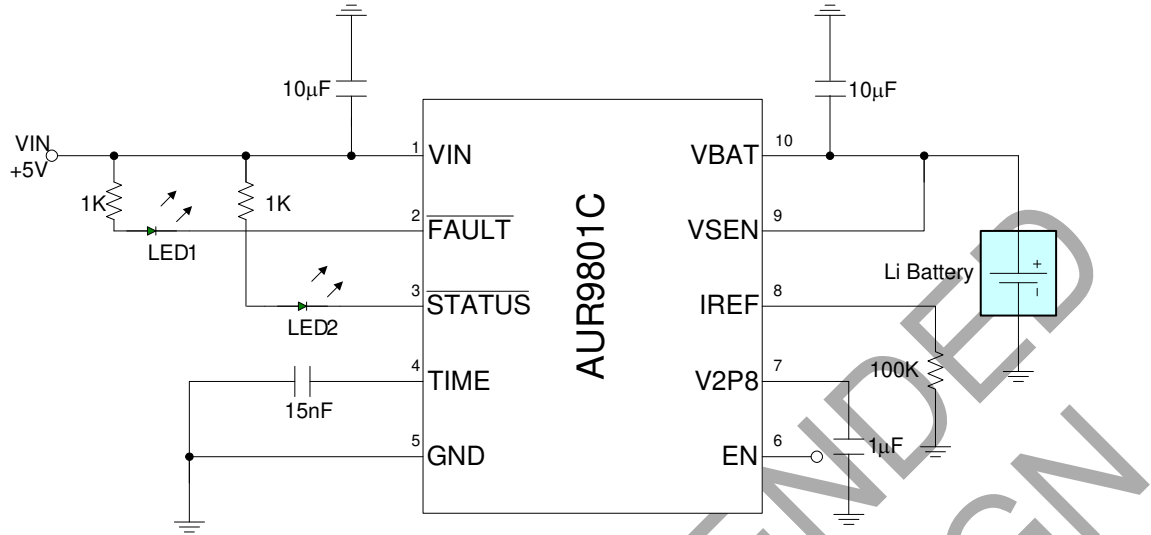

Figure 9. Typical Application Circuit

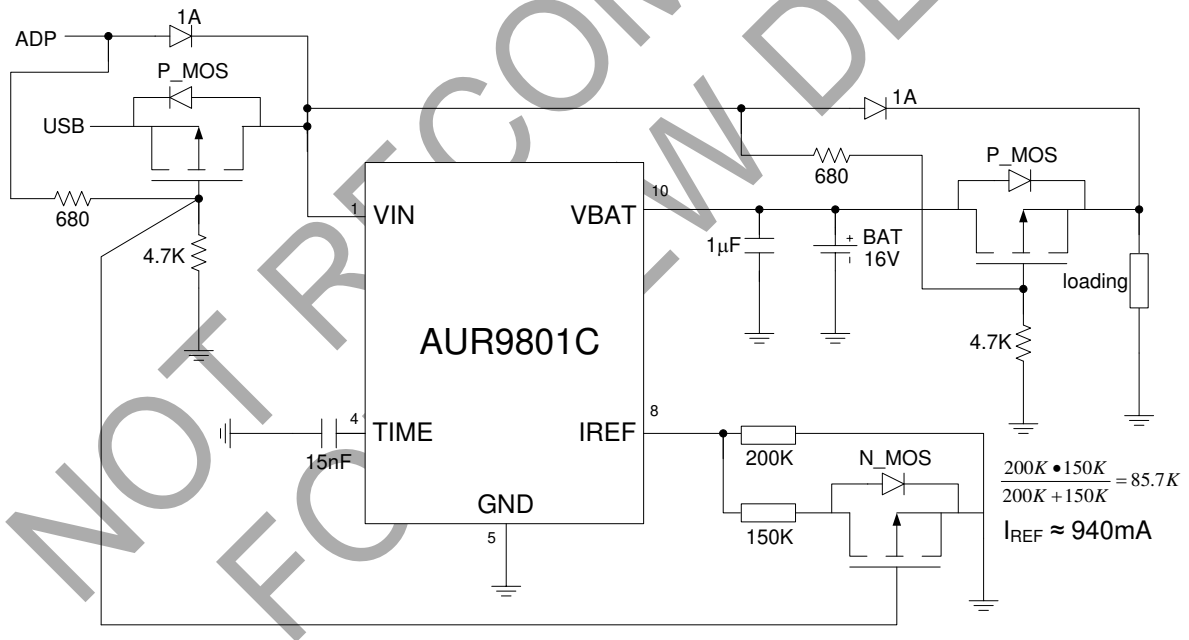

Figure 10. External Power Path Application Circuit



NOT RECOMMENDED FOR NEW DESIGN

Li-ion/Li Polymer Battery Charger **AUR9801C**

Mechanical Dimensions

WDFN-3x3-10

Unit: mm(inch)

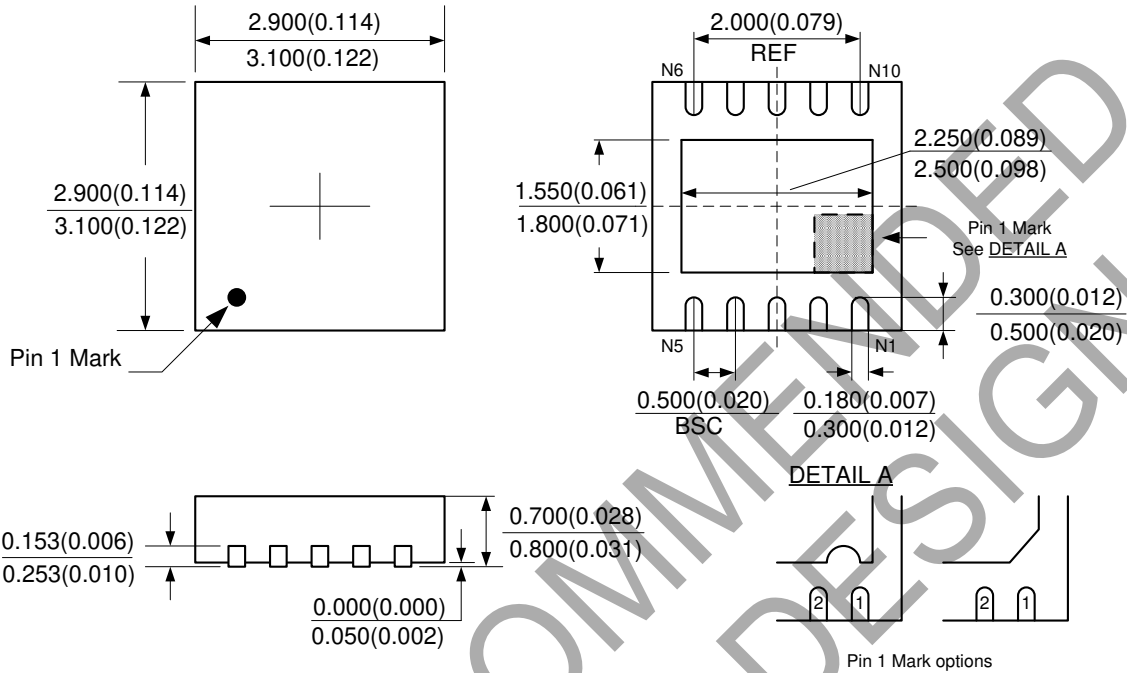



BCD Semiconductor Manufacturing Limited

<http://www.bcdsemi.com>

IMPORTANT NOTICE

BCD Semiconductor Manufacturing Limited reserves the right to make changes without further notice to any products or specifications herein. BCD Semiconductor Manufacturing Limited does not assume any responsibility for use of any its products for any particular purpose, nor does BCD Semiconductor Manufacturing Limited assume any liability arising out of the application or use of any its products or circuits. BCD Semiconductor Manufacturing Limited does not convey any license under its patent rights or other rights nor the rights of others.

MAIN SITE

- Headquarters

BCD (Shanghai) Micro-electronics Limited

No. 1600, Zi Xing Road, Shanghai ZiZhu Science-based Industrial Park, 200241, P. R. C.
Tel: +86-021-2416-2266, Fax: +86-021-2416-2277

- Wafer Fab

Shanghai SIM-BCD Semiconductor Manufacturing Co., Ltd.

800 Yishan Road, Shanghai 200233, China
Tel: +021-6485-1491, Fax: +86-021-5450-0008

REGIONAL SALES OFFICE

Shenzhen Office

Shanghai SIM-BCD Semiconductor Manufacturing Co., Ltd., Shenzhen Office

Unit A Room 1203, Skyworth Bldg., Gaoxin Ave.1.S., Nanshan District
Shenzhen 518057, China

Tel: +86-0755-8660-4900, Fax: +86-0755-8660-4958

Taiwan Office (Taipei)

BCD Semiconductor (Taiwan) Company Limited

3F, No.17, Lane 171, Sec. 2, Jiu-Zong Rd., Nei-Hu Dist., Taipei(114), Taiwan, R.O.C
Tel: +886-2-2656-2808

Fax: +886-2-2656-2806/26562950

Taiwan Office (Hsinchu)

BCD Semiconductor (Taiwan) Company Limited

8F, No.176, Sec. 2, Gong-Dao 5th Road, East District
HsinChu City 300, Taiwan, R.O.C

Tel: +886-3-5160181, Fax: +886-3-5160181

USA Office

BCD Semiconductor Corp.

48460 Kato Road, Fremont, CA 94538, USA
Tel: +1-510-668-1950

Fax: +1-510-668-1990

Korea Office

BCD Semiconductor Limited Korea office.

Room 101-1112, Digital-Empire II, 486 Sin-dong,
Yeongtong-Gu, Suwon-city, Gyeonggi-do, Korea

Tel: +82-31-695-8430