

SPECIFICATION CONTROL DRAWING

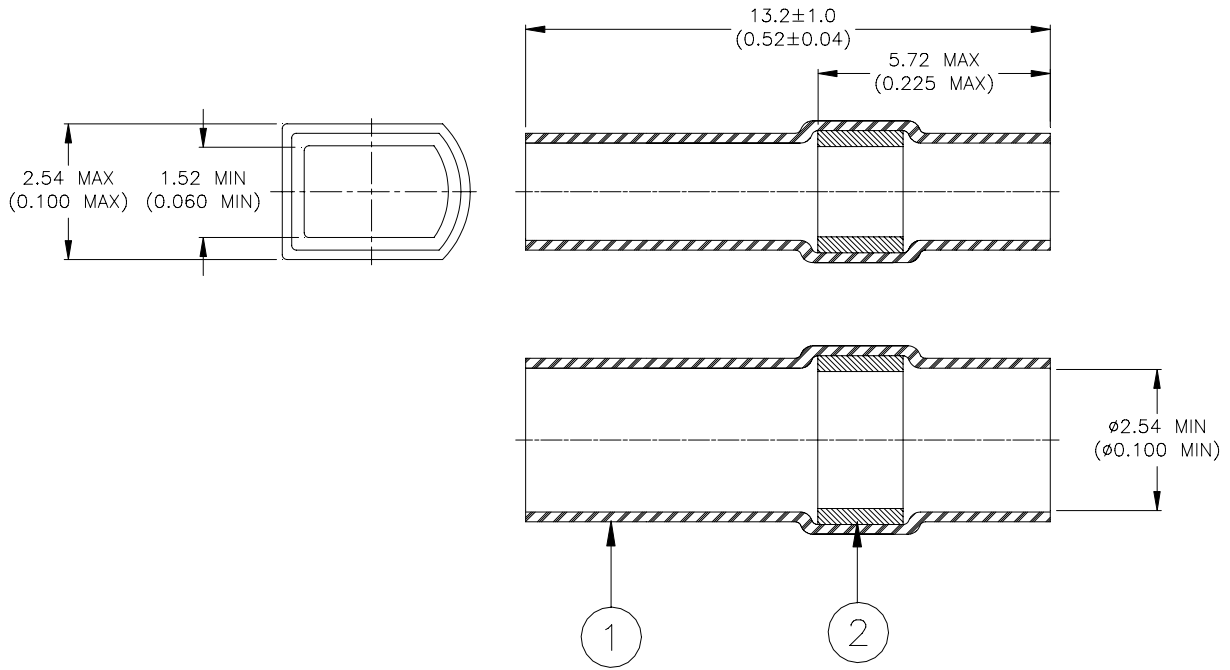

MATERIALS

1. **INSULATION SLEEVE:** Heat shrinkable, transparent blue, radiation cross-linked modified polyvinylidene fluoride.
2. **SOLDER PREFORM WITH FLUX:**
SOLDER: TYPE Sn63 per ANSI J-STD-006.
FLUX: TYPE ROL1 per ANSI J-STD-004.

APPLICATION

1. This part is designed to be used in conjunction with a Raychem AS-4000 Wire Organization System to attach tin or silver plated wires to connector terminals on 2.54 (0.100) or greater center spacing.
Wire Accommodation:
Single wire:
 Jacket O.D.: 1.52 (0.060) max.
 Wire Gauge: 26 - 20
Connector Terminal:
 Max. Width: 1.52 (0.060)
 Min. Height: 4.45 (0.175)
2. Sleeve will recover to 1.27 (0.050) max. I.D.
3. This drawing forms part of Raychem Devices Specification Control Drawings:
 D-704-0010, 2.54 (0.100) centers.
 D-704-0012, 3.18 (0.125) centers.

tyco / Electronics / Raychem		Wire and Harnessing Products		TITLE : (AS-4000) SOLDERSLEEVE WIRE TERMINATOR			
307 Constitution Drive Menlo Park, CA 94025, USA				DOCUMENT NO.: D-128-0008			
Unless otherwise specified dimensions are in millimeters. Inches dimensions are in between brackets.							
TOLERANCES: 0.00 N/A 0.0 N/A 0 N/A	ANGLES: N/A ROUGHNESS IN MICRON	Tyco Electronics reserves the right to amend this drawing at any time. Users should evaluate the suitability of the product for their application.		DCR NUMBER: D010029	REPLACES: N/A		
DRAWN BY: M. FORONDA	DATE: 08-Feb.-01	PROD. REV. E	DOC ISSUE: 1	SCALE: None	SIZE: A	SHEET: 1 of 1	

If this document is printed it becomes uncontrolled. Check for the latest revision.