

REV.	DATE	ECR NO.	DESCRIPTION
NC	03/08/11	XXXXXX	INITIAL RELEASE

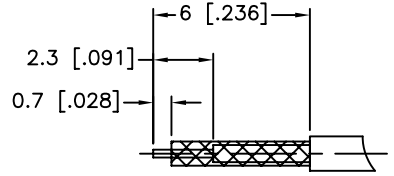

RECOMMENDED  
CABLE STRIPPING DIM'S

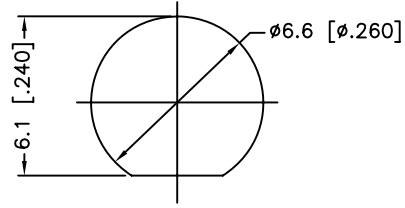

RECOMMENDED  
MOUNTING HOLE

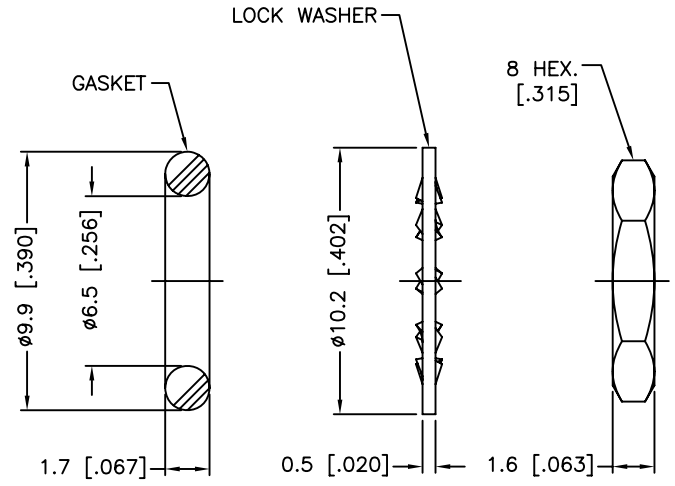
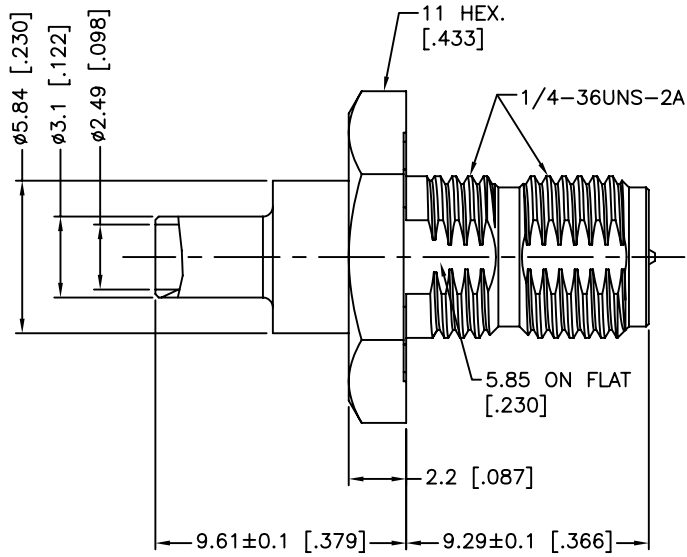
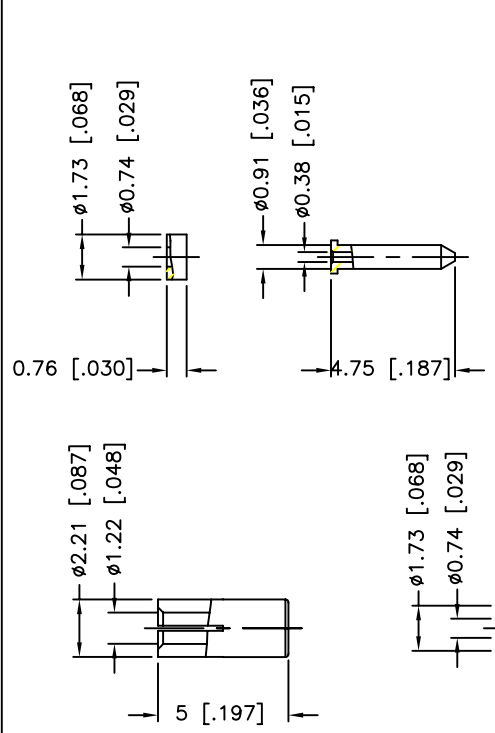

- NOTE:
1. FREQUENCY RANGE: DC 0-6 GHz
  2. VSWR(RETURN LOSS): 1.28(18.22 dB), MAX.
  3. IP-67 COMPLIANT
  4. CRIMPED FERRULE  
HEX CRIMP SIZE .105"
  5. CONTACT PIN TO SOLDER
  6. MAX. PANEL THICKNESS=0.93mm

11	HEX NUT	BRASS	GOLD	1
10	LOCK WASHER	BRASS	GOLD	1
9	GASKET	SILICONE	RED	1
8	INNER FERRULE	BRASS	GOLD	1
7	SLEEVE	BRASS	GOLD	1
6	INSULATOR	PTFE	NATURAL	1
5	CONTACT PIN	BRASS	GOLD	1
4	O-RING	SILICONE	RED	1
3	CONTACT PIN	BRASS	GOLD	1
2	INSULATOR	PTFE	NATURAL	1
1	BODY	BRASS	GOLD	1
	DESCRIPTION	MATERIAL	FINISH	QTY

UNLESS OTHERWISE SPECIFIED DIMENSIONS ARE IN MILLIMETERS. DIMENSIONS IN ( ) ARE IN INCHES AND FOR CUSTOMER REFERENCE ONLY.

UNLESS OTHERWISE SPECIFIED TOLERANCES FOR MILLIMETERS ARE:  
0.5 - 8mm ± 0.20mm  
8 - 30mm ± 0.40mm  
30 - 120mm ± 0.50mm

UNLESS OTHERWISE SPECIFIED TOLERANCES FOR INCHES ARE:  
.020 - .315 ± 0.007"  
.315 - 1.180 ± 0.015"  
1.180 - 4.724 ± 0.020"

DO NOT SCALE DRAWING

APPROVALS	DATE
DRAWN M.ZHANG	03/08/11
CHECKED	
ISSUED	
SHEET 1 OF 1	
CAD FILE	C:/CONNEX/132422RP.DWG

**Amphenol Connex**

PART DESCRIPTION  
**RP-SMA BULKHEAD CRIMP JACK, REAR MOUNT SEALED IP-67 COMPLIANT (FOR 1.13 MM CABLE)**

PART NO.  
**132422RP**

DWG. NO. 132422RP.DWG    REV. NC    SIZE A    SCALE NA