

- *Vibration & Shock
- *Small Size
- *Sensitivity 3.5 pC/g
- *Low Base Strain Sensitivity
- *Electrical Isolation

The Model 7002 and 7003 Piezoelectric Accelerometers are ideal for dynamic testing applications where small size, low mass, and performance reliability are the important criteria. They are designed for the measurement of medium frequency, moderate to high-level shock and vibration.

These sensors incorporate a unique, inverted ring-shear crystal mass assembly within a stainless steel body to provide a reliable sensor that is insensitive to environmental inputs such as base bending and thermal transients. The isolated case construction provides exceptional electrical isolation which yields accurate, wideband shock and vibration data. High temperature units will operate in environments up to +500 Deg. F. *Consult the factory for customized versions of these sensors.*

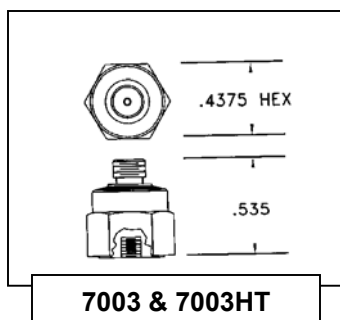
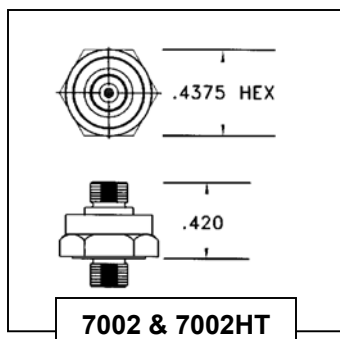

Specifications

Transfer / Electrical	7002 & 7002-HT	7003 & 7003-HT
Charge Sensitivity ¹	3.5 +/-0.5 pC/g	
Capacitance	250 +/-50 pF	
Frequency Linearity ²	+/-5% Max 2 Hz To 5,000 Hz	
Mounted Resonant Frequency	25 KHz, Nom.	
Transverse Sensitivity	5% Max	
Amplitude Linearity	+/-1.0% (BFSL) / 300 g	
Insulation Resistance	20,000 M Ohm Min, 50 VDC Test	
Isolation Resistance	100 M Ohm, Min.	

Environmental

Vibration Limit	1,000 g Max (Sine)	
Shock Limit	2,000 g Max	
Temperature Range	Models 7002 & 7003 -65 To +350 Deg F (-55 To +175 Deg C) Models 7002-HT & 7003-HT -65 To +500 Deg F (-55 To +260 Deg C)	
Humidity ³	0 To 98% R.H. (Non-Condensing)	
Base Strain Sensitivity	0.003 g/uE Equiv, Typical	
Electromagnetic Sensitivity	0.01 g (Equiv / 100 Gauss)	

Physical

Configuration	Inverted Ring Shear	
Size	0.438 In. Hex x 0.420 In. H 11.1 mm Hex x 10.7 mm H	0.438 In. Hex x 0.535 In. H 11.1 mm Hex x 13.6 mm H
Weight	0.16 Oz (4.5 Gm)	0.25 Oz (7.0 Gm)
Case Material	18-8 Stainless Steel	
Electrical Interface	Coaxial 10-32 Thread	
Mounting	10-32 Integral Stud	4-48 Removable Stud

NOTES:

¹ At +75 Deg F, 10g Peak, 100Hz; Lower Frequency Limit is Determined by Associated Electronics

² Referenced to Sensitivity @ 100 Hz.

³ With Connector Protected or Sealed, Unit is Epoxy Sealed

Accessories Supplied:

- (1) Miniature Cable Assembly, LNHT-3'
- (1) 4-48 x 0.25"L Mounting Stud, St. Stl.
(Models 7003 and 7003-HT only)
- (1) Hardwood Storage Case
- (1) Standard Calibration Data
- (1) Certificate of Calibration Traceable to N.I.S.T.