

Features and Benefits

- Four grades of magnetic materials
- Cost effective design
- High resistance to demagnetization
- Operation from -40°C to 125°C
- Tough environmental endurance
- Very resistant to chipping



Molded Target Magnet

Physical Properties of Magnetic Material

Table 1.1

| Characteristic | Value | Units |
|--------------------------------|-----------------------|-------|
| Tensile Strength | 6500 | PSI |
| Flexural Strength | 9750 | PSI |
| Flexural Modulus | 1.3 X 10 ⁶ | PSI |
| Continuous Service Temperature | 100 | °C |

Magnetic Properties

Table 1.2

| Characteristic | Magnalox 300 | Neobond 12M | Neobond 30M | Neobond 32P | Units |
|---|--------------|-------------|-------------|-------------|---------|
| Remanence (B _r) | 1370 | 2500 | 4000 | 4300 | Gauss |
| Coercive Force (H _c) | 1180 | 2400 | 3250 | 2500 | MGOe |
| Energy Product (BH _{MAX}) | 0.40 | 1.3 | 3.1 | 3.2 | Oersted |
| Intrinsic Coercive Force (H _{ci}) | 2300 | 7500 | 7000 | 6900 | Oersted |
| Reversible Temperature Coefficient | -0.2 | -0.35 | -0.4 | -0.4 | /°C |
| Specific Gravity | 3.5 | 4.0 | 4.7 | 4.45 | --- |

Pole Counts

Alternating north and south magnetic poles are symmetrically located on the outer diameter for radial sensing.

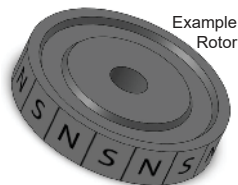

Note: (N)orth/(S)outh markings are for illustration and do not appear on the actual product.

| | |
|-----------------------|---------------------|
| Available Pole Counts | 32, 36, 50, 64, 120 |
|-----------------------|---------------------|

Target Rotor Physical Outline - Aluminum Hub (Mounting Style B)

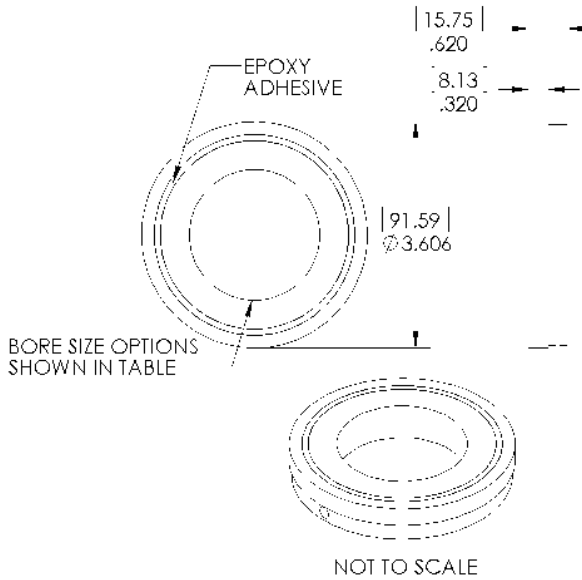

Table 3.1

| | Motor Shaft OD Size (nominal) | NEMA Guide Shaft Tolerance | Magnet Bore MIN. (inch) | Magnet Bore MAX. (inch) |
|------|-------------------------------|----------------------------|-------------------------|-------------------------|
| 1000 | 1 in (1.0000") | +0.0000"/-0.0005" | 1.0009 | 1.0020 |
| 1125 | 1 1/8 in (1.1250") | | 1.1259 | 1.1270 |
| 1182 | 30 mm (1.1820") | | 1.1829 | 1.1840 |
| 1375 | 1 3/8 in (1.3750") | | 1.3759 | 1.3770 |
| 1500 | 1 1/2 in (1.5000") | | 1.5009 | 1.5020 |
| 1625 | 1 5/8 in (1.6250") | | 1.6259 | 1.6270 |
| 1875 | 1 7/8 in (1.8750") | | 1.8759 | 1.8770 |
| 2000 | 2 in (2.0000") | | 2.0009 | 2.0020 |
| 2125 | 2 1/8 in (2.1250") | | 2.1259 | 2.1270 |
| 2250 | 2 1/4 in (2.2500") | | 2.2509 | 2.2520 |
| 2375 | 2 3/8 in (2.3750") | | 2.3759 | 2.3770 |
| 2500 | 2 1/2 in (2.5000") | | 2.5009 | 2.5020 |
| 2750 | 2 3/4 in (2.7500") | | 2.7509 | 2.7520 |

Other bore sizes available upon request.
Contact sales@phoenixamerica.com.

Target Rotor Mounting Guidelines - Aluminum Hub (Mounting Style B)

- Proper alignment of the target rotor is critical for optimal performance.
- A machined step in the motor shaft provides a quick and repeatable method for positioning the target rotor. Spacers or other fixturing should be used to properly position the rotor if no mechanical locating features are on the shaft.
- While the hub is held in the proper position, use a hex wrench to tighten #10-32 set screw.
- For permanent applications, a threadlocker or retaining compound is advised in conjunction with the set screw.

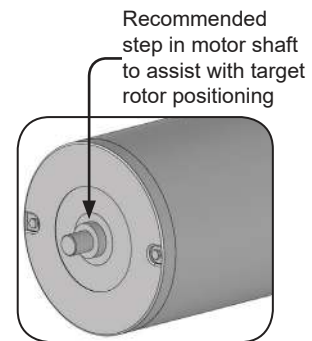

Part Number Description

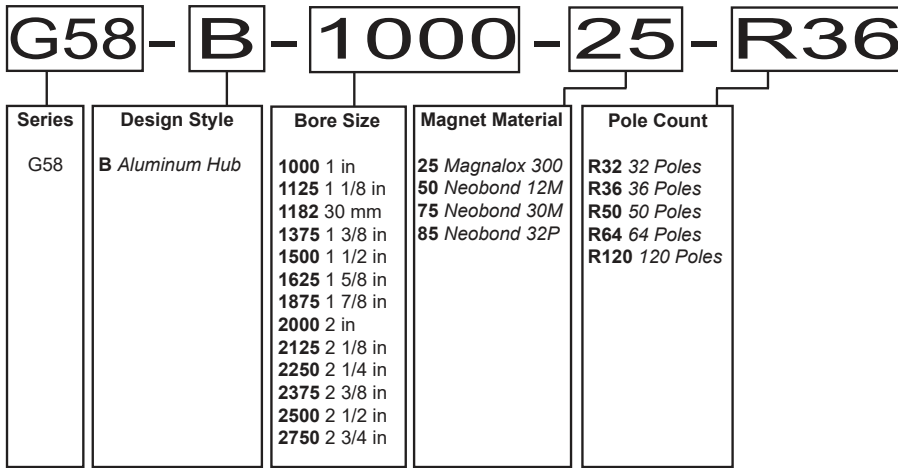

Example: G58-B-1000-25-R36