

IGBT BASED DC SOLID STATE RELAY

SDI0501710



Nominal Control voltage	72-96 & 110VDC
Nominal. output voltage	750VDC
Nom. load current with heatsink	50ADC

- ▶ Latest IGBT technology generation.
- ▶ Ultra low drop out voltage at on-state (low power losses).
- ▶ Built-in protection against overvoltage and fasts transients bursts.
- ▶ Built-in protection against overload and shorts-circuits of the load.
- ▶ Built-in over-temperature protection.
- ▶ Pluggable control connector with spring terminals

Load voltage range	Load current range	Control input voltage	Supply voltage range	Visualizations	Dimensions (WxHxD)	Weight
12 to 940VDC	0 à 50A (with heatsink)	72-96-110VDC	72-96-110VDC	3 LEDs : -SUPPLY (Green) -STATUS (Orange) -FAULT (Red)	157 x 68 x 83 (mm)	1050g

Fig. 1

INTERNAL DIAGRAM

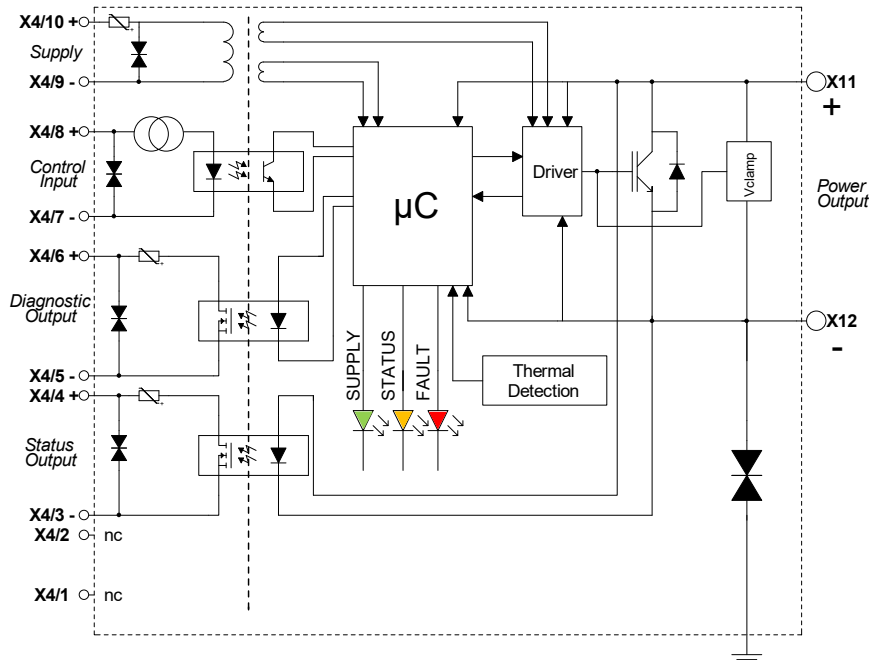

Proud to serve you

Fig. 2

EXAMPLES OF WIRING DIAGRAM

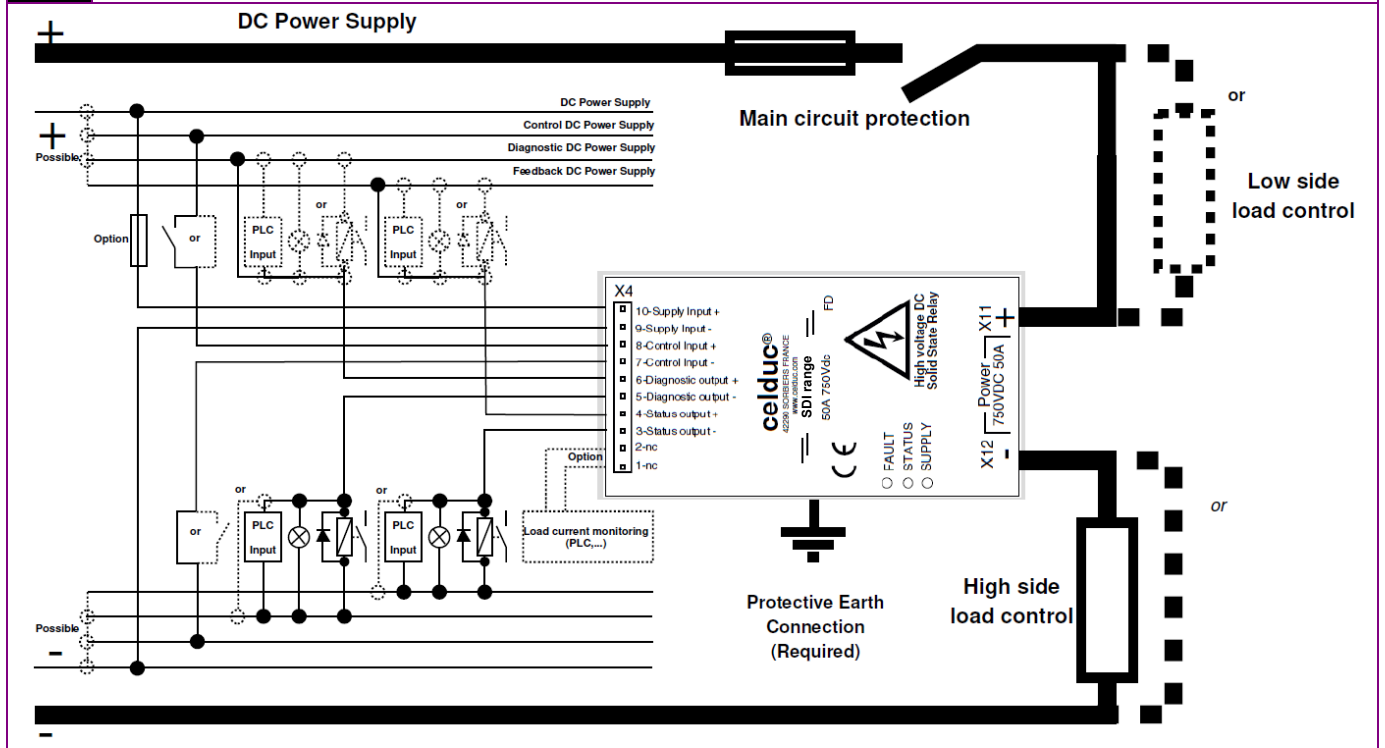

SUPPLY INPUT

	CHARACTERISTIC	LABEL	VALUE	INFO.
SUPPLY CIRCUIT	Marking		X4/10 & X4/9	
	Nom. supply voltage	Us	72/96/110Vdc	
	Min. supply voltage	Us min	50.4Vdc	
	Max. supply voltage	Us max	137.5Vdc	
	Max. peak voltage	Usp	154Vdc	@pulse<1s
	Typ. operating current	Is	<40mA	
	Max. reverse current	-Is	<1µA	
	Overvoltage protection		Transient voltage suppressor	
	Internal Overcurrent and shorts-circuits protection		Thermistor	
	Reverse polarity protection		YES	
Under Voltage Lockout protection UVLO		YES		

Proud to serve you

CONTROL INPUT

	CHARACTERISTIC	LABEL	VALUE	INFO.
INPUT CIRCUIT	Marking		X4/8 & X4/7	
	Control voltage range	Uc	72/96/110Vdc	
	Current consumption	Ic	<5mA	See fig. 3
	Max. reverse current	-Ic	<1μA	
	Min. switch-on voltage	Uc_on_min	43.2V	
	Min. releasing voltage	Uc_off_min	4Vdc	
	Max. input voltage	Ucmax	137.5Vdc	
	Max. reverse voltage	-Ucmax	137.5Vdc	
	Input impedance	Re	Current limitation	

Fig. 3

CONTROL INPUT CHARACTERISTICS

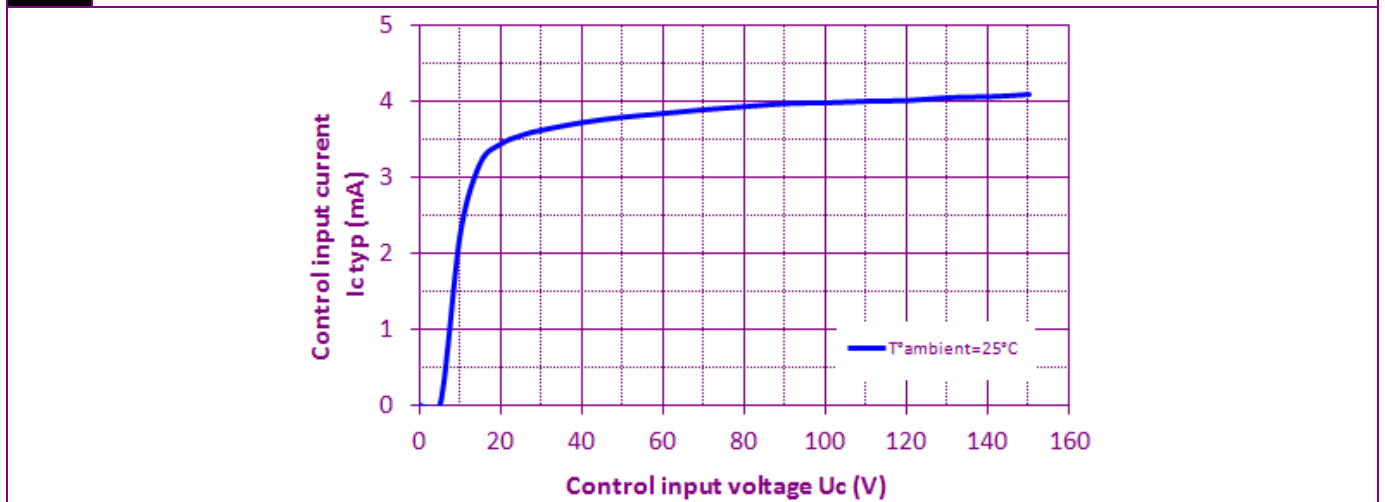

POWER OUTPUT

Proud to serve you

	CHARACTERISTIC	LABEL	VALUE	INFO.
POWER CIRCUIT	Nom. power voltage	Ue	750Vdc	
	Min. power voltage	Uemin	12Vdc	
	Max permanent voltage	Umax1	940Vdc	
	Non-permanent voltage	Umax2	1000Vdc	@pulse<5min
	Repetitive peak voltage	Umax3	1270V	@pulse<20ms
	Max. nominal currents	Ice	50A	See fig. 4 Values with heatsink
	Min. nominal currents	Ice min	0.1A ^(*1)	
	Non-repetitive IGBT peak overload current	Icepeak	300A	See fig. 8
	Max. leakage current	Icelk	15µA	
	On-state voltage	VCEsat	1.08V	See fig. 5 @Ie=50A
	Reverse voltage (internal diode)	-Ut	1.12V	See fig. 6 @Ie=50A Tj=125°C
	Max. inductive load (load + line length)		5mH	See fig. 9 @Ie=50A Tjmax=125°C
	Overvoltage protection		Activ Clamp Protection	
	Shorts-circuits/Overload protection		Automatic Desaturation detection	
	Nominal desaturation current detection	Ice desat	225A	@Tj=25°C
	Min Desaturation detection time		7µs	
	Max. single pulse avalanche energy	Eep	20J	@tpulse=1ms
	Max. repetitive pulse avalanche energy	Eep	5J	@Ie=50A
	Typ. output capacitance	Cout	1.65nf	@Uc=0
	IGBT junction/case thermal resistance	Rthjc	0.054K/W	See fig. 7
	Reverse diode junction/case thermal resistance	Rthjc	0.11K/W	See fig. 7
	Built-in heatsink thermal resistance vertically mounted	Rthra	2.4K/W	@ΔTra=65°C
	Heatsink thermal time constant	Tthra	30min	@ΔTra=65°C
	Maximum junction temperature	Tjmax	105°C	@Ie=50A
	Storage temperature	Tstg	-40->+85°C	
	Operating temperature	Tamb	-40->+70°C	
	Ambient humidity	Hr	5 à 95%	

(*1) To have a good diagnostic operation, we recommend a minimum load current of 3Amps.

Proud to serve you

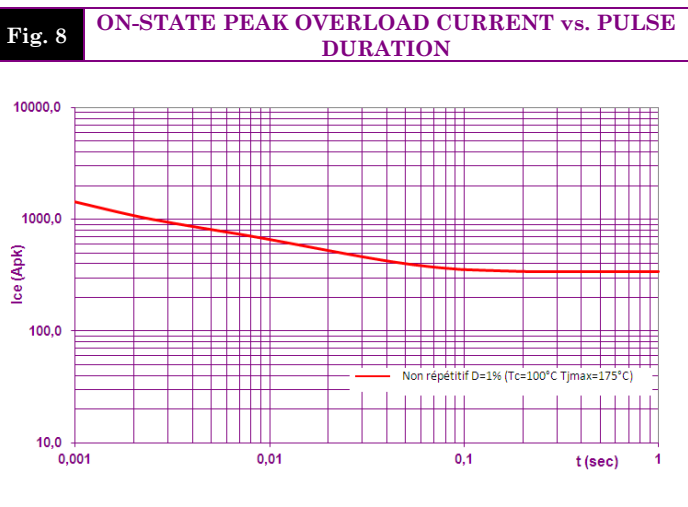
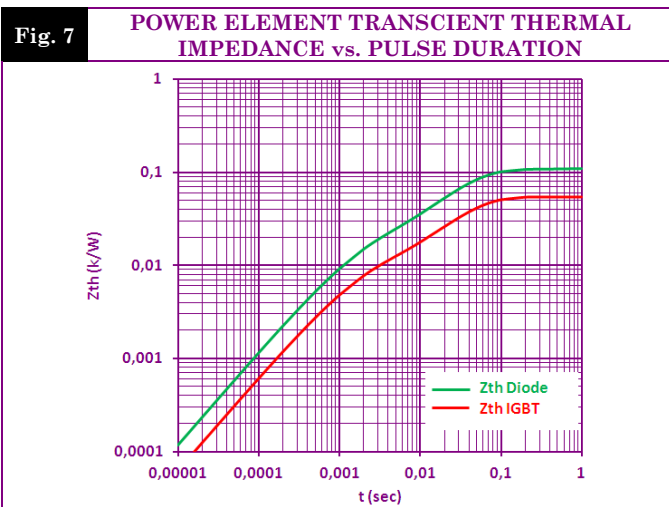
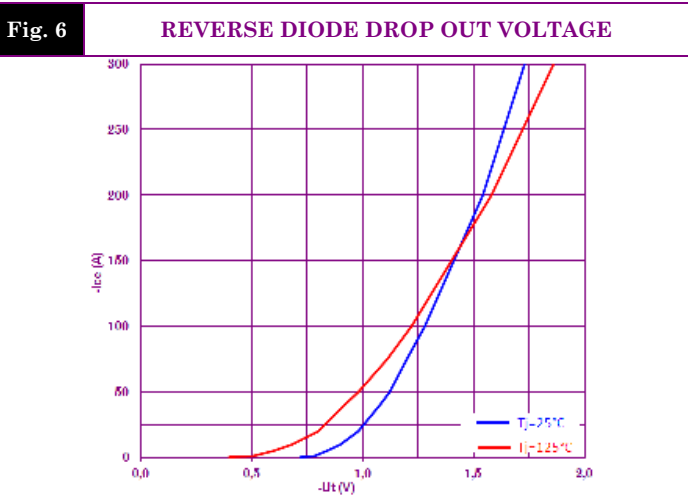
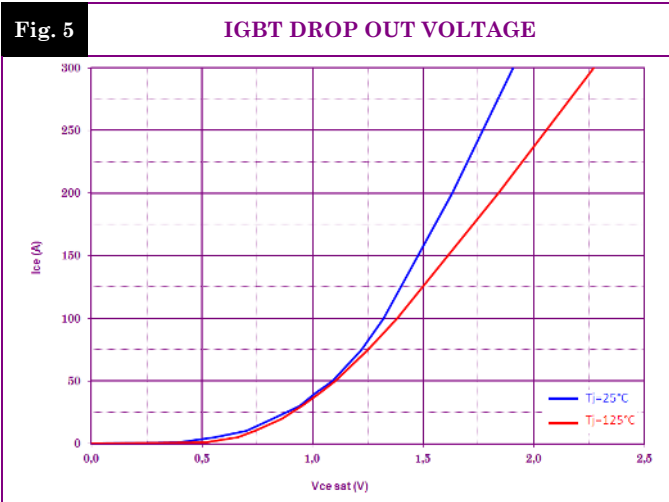
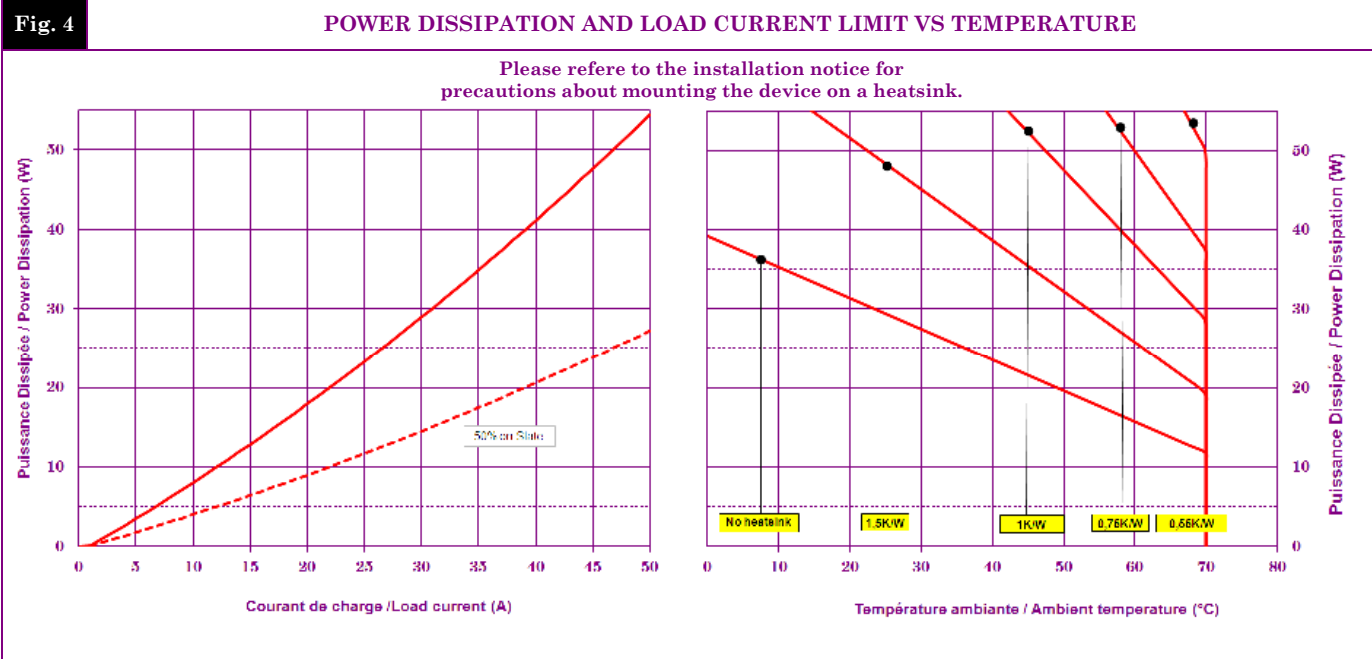

Proud to serve you

Data given at Tambient=40°C and subject to modification without previous notice

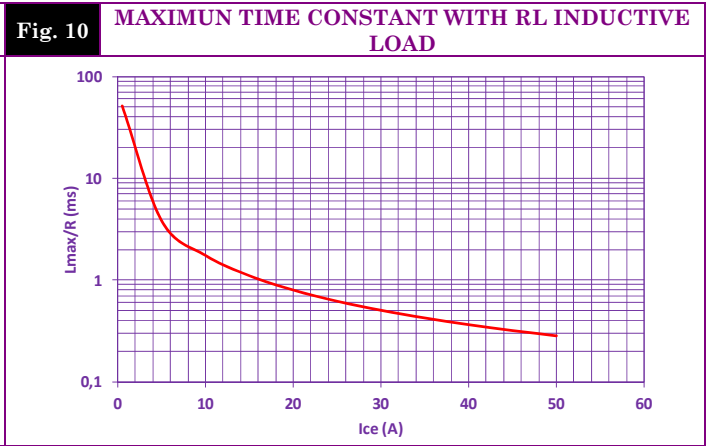
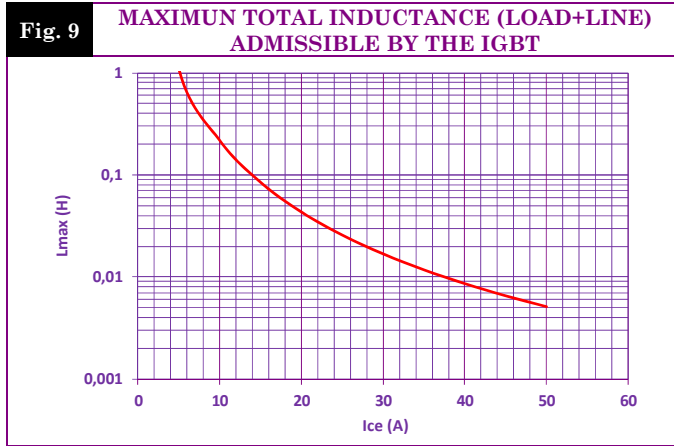

DIAGNOSTIC & STATUS OUTPUTS

CHARACTERISTIC	LABEL	VALUE	INFO.
Marking		X4/6 & X4/5 (Diagnostic Output) X4/4 & X4/3 (Status Output)	
Type of contact		Semiconductor (Photo-MOS) NO Contact ("Opened" without activation or supply)	
Nominal switching voltage		72/96/110Vdc	
Max. switching voltage		137.5Vdc	
Min. switching voltage		16.8Vdc	
Max. switching current		50mA	
Min. switching current		0.1mA	
Max. on-state resistance	Rds_on	35Ω	
Overvoltage protection		Transient voltage suppressor	
Overload and shorts-circuits protection		Thermistor	
Reverse polarity protection		YES	

DIAGNOSTIC & STATUS OUTPUTS

SUPPLY INPUT	CONTROL INPUT	MAIN VOLTAGE	LOAD CIRCUIT	RELAYS BASEPLATE TEMPERATURE	SUPPLY LED	STATUS LED	FAULT LED	DIAGNOSTIC OUTPUT	STATUS OUTPUT
0	x	x	x	x	○	○	○	Open	Open
UVLO	x	x	x	x	◐	○	○	Open	Open
1	0	YES	OK	<90°C	●	○	○	Open	Open
1	1	YES	OK	<90°C	●	●	○	Open	Closed
1	0	NO	OK	<90°C	●	○	◐	Closed	Open
1	1	NO	OK	<90°C	●	●	◐	Closed	Closed
1	0	YES	BREAKING	<90°C	●	●	◐	Closed	Open
1	1	YES	BREAKING	<90°C	●	●	◐	Closed	Closed
1	1	YES	OVERLOAD ^(*)	<90°C	●	○	◐	Closed	Open
1	1	YES	SHORT-CIRCUIT ^(*)	<90°C	●	○	◐	Closed	Open
1	0	x	≠0A	x	●	●	◐	Closed	Closed
1	x	x	x	>90°C	●	○	●	Closed	Open

LEGEND:

- ◐ Flashing ton=0,1s toff=0,1s
- ◑ Flashing ton=0,1s toff=2s
- ◒ Flashing ton=1s toff=1s
- ◐ Flashing ton=0,1s toff=0,1s

(*) After four Short-circuits and/or overload detection, the relay will block for safety, this mode is indicated by a flashing chaser of leds, in this case the diagnostic output would be closed and the Status output would be open, to cancel this fault, you should reset the product with supply input (pin X4/6 et X4/5).

Proud to serve you

TIME CHARACTERISTICS

Fig. 2

TIME DIAGRAM

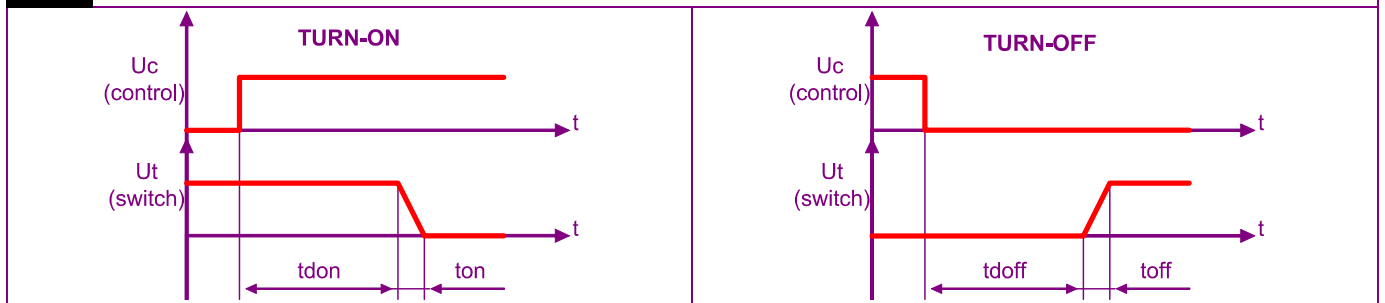

TIME CHARACT.	CHARACTERISTIC	LABEL	VALUE	INFO.
	Turn on time	ton	1ms	Rload=20Ω Lload=5mH Ue=750Vdc
	Turn on delay	tdon	1.5ms	
	Turn off time	toff	300μs	Rload=20Ω Lload=5mH Ue=750Vdc
	Turn off delay	tdoff	1.5ms	
	Max. On-Off frequency	F(on-off)	1Hz	

GENERAL INFORMATION

WIRING	Connections	Power	Control
	Type	M6 Hexagonal screw	Cage spring with manual lever plug
	Tightening torque	3.75Nm	By pushing with DIN 5264 Screwdriver 0.4x2.5
	Recommended wiring type	round tabs, eyelet type, M6	1x1.5mm2 max
Plastic material housing	WELLAMID 6600 PA66 HWV0CP		
Mounting	4 screws M5		See mounting sheet
Noise level	No audible noise		
Weight	1050g		

Proud to serve you

STANDARDS

GENERAL	Standards		EN50155	
	Temperature class		TX	
	Protection level		IP00	
	CE marking		Yes	
	UL, cULUS and VDE approvals		Possible on request	
	Reliability		MTTF = 118 years MTTFd ≥ 24 years	ISO13849-1 @40°C/750Vdc and 50A

INSULATION	Standards		EN50124-1	
	Overvoltage categories		OV4 @72-96Vdc OV3 @110Vdc	
	Pollution Degree		PD2	
	Rated impulse voltage between Input and Power outputs	Uni	8kV	
	Rated insulation voltage between Input and Power outputs	Unm	0.9kV	
	Rated impulse voltage between different signals of X4 connector (supply, control input, Diagnostic output and Status output)		2.5kV	
	Rated impulse voltage between Power output and ground (Aluminum baseplate)		4kV ^(*3)	

(*3) Warning: The rated impulse voltage test can damage the reliability of some components, we invite you to do this insulation test with reduced voltages (1500Vpk).

E.M.C. IMMUNITY	TYPE OF TEST	STANDARD	RESULTS	TESTS STANDARD
	E.S.D. (Electrostatic discharges)	EN50121-3-2	PASS	EN61000-4-2
	Radiated electromagnetic fields	EN50121-3-2	PASS	EN61000-4-3
	Fast transients bursts	EN50121-3-2	PASS	EN61000-4-4
	Electric chocks	EN50121-3-2	PASS	EN61000-4-5
	Radio-frequency fields	EN50121-3-2	PASS	EN61000-4-6

E.M.C. EMISSION	Radiated and conducted disturbances	EN50121-3-2	PASS	EN55011
------------------------	-------------------------------------	-------------	------	---------

OTHERS	Fire & smoke protection	EN45545-2	HL2 with requirement R22	
	Mechanical test Shocks and Vibrations	EN61373	PASS	

Proud to serve you

DIMENSIONS

Fig. 8

DIMENSIONS (in mm)

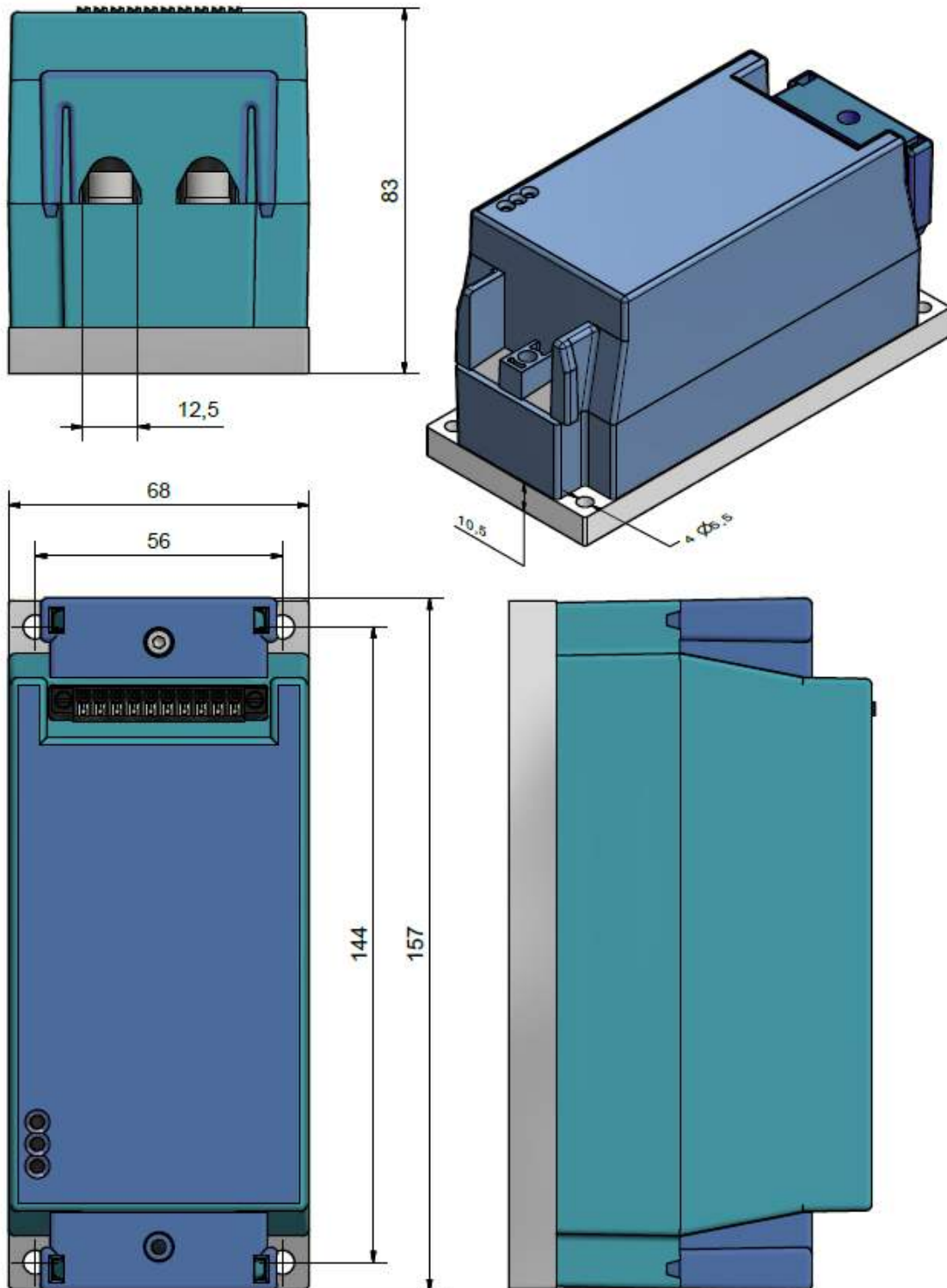

Proud to serve you

Data given at Tambient=40°C and subject to modification without previous notice

CONNECTIONS-WIRING

CONTROL CONNECTOR

X4/1

X4/10

==>Spring connector
« PUSH IN »

3.81

1.5 mm²

180°

GROUND WIRING

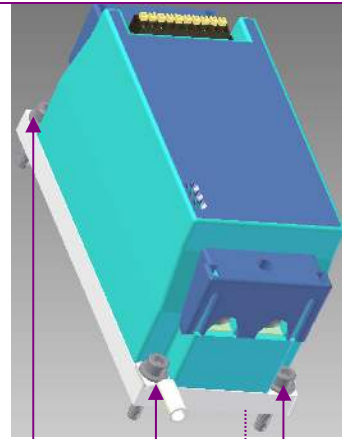

The Ground-wiring of the product with the rest of installation is made by screwing directly to the relay baseplate with one of the 4 holes (M5).
Fastening screws and round terminals (power, ground...) are not supplied with the product.

POWER WIRING

X12 -

X11 +

B max=12mm
d min=6.2mm
N max=7mm

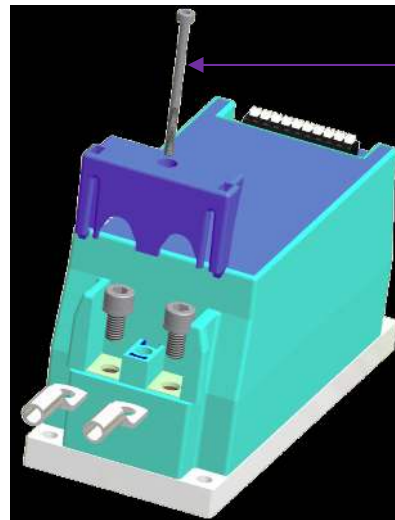

Locking of plastic covers by screws CHC M3
Maximum tightening torque: 1.0Nm

Proud to serve you

Data given at Tambient=40°C and subject to modification without previous notice

OPTIONS

Control connector with screws :

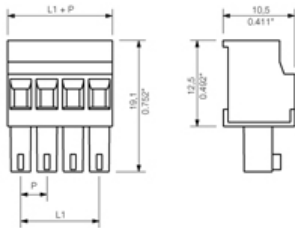
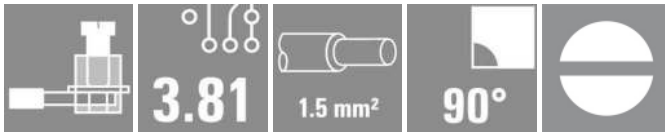

Connection kit for large cable ends :

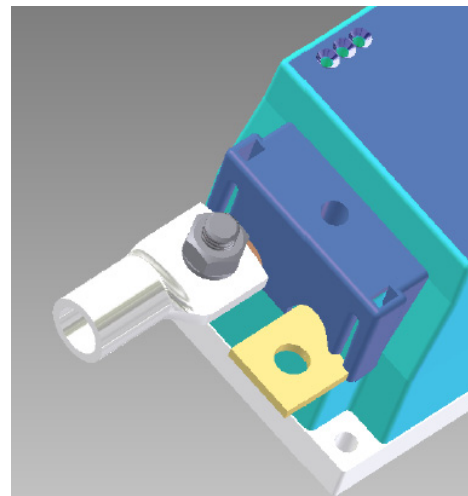
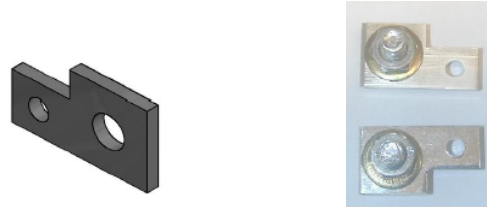

Possibility of current measurement output (isolated) on signal connector (pin X4/9 and X4/10):

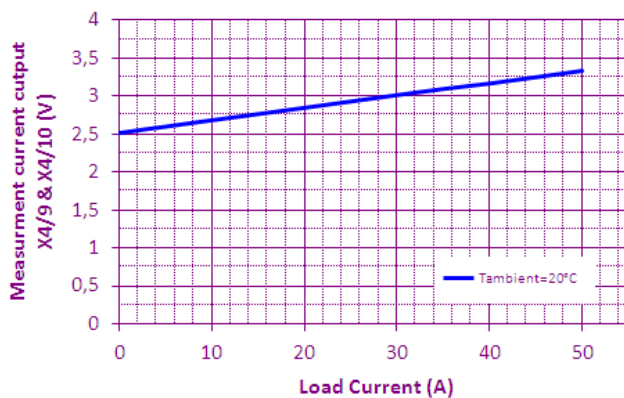

Please consult our website for other accessory references (Heatsink, mounting adaptors, thermal grease...).