

COMPONENT MOUNT SIDE  
PWB THICKNESS 1.60MM  
(DEFAULT TOLERANCE ±0.05MM)

NOTE :

- MATERIAL :  
HOUSING : THERMOPLASTIC 30% GLASS FILLED , BLACK.UJ94V-0  
TERMINAL : COPPER ALLOY THICKNESS 0.20mm±0.02.  
SHELL : STAINLESS STEEL THICKNESS 0.30mm.
- PLATING :  
TERMINAL:  
CONTACT AREA : GOLD 0.76 MICROMETER MIN.  
SOLDERING AREA : MATTE TIN 3.8 MICROMETER MIN.  
UNDERPLATING : NICKEL 1.27 MICROMETER MIN.  
SHELL:  
OVERALL SOLDERING NICKEL 1.27 MICROMETER MIN.
- PRODUCT CHARACTERS SPEC: PER PS-105057-001.
- PACKAGE INFORMATION: PER PK-105057-005.
- THE PART COMPLIANT TO RoHS DIRECTIVE 2011/95/EU AND ELV 2000/53/EC.

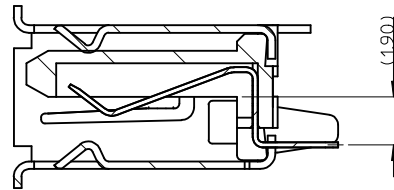
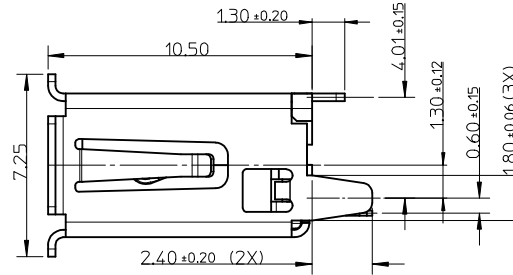
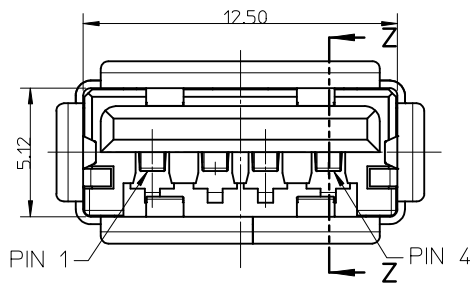

SECTION Z-Z

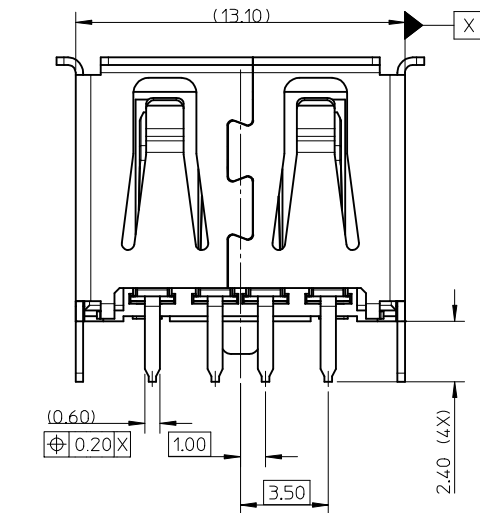

RELEASE EC NO: SH2016-0099 DRW: F YANG05 CHKD: APPR: RZHANG REV: A	DESCRIPTION 2015/09/18 2015/10/06	QUALITY SYMBOLS	GENERAL TOLERANCES (UNLESS SPECIFIED)		DIMENSION STYLE	SCALE	DESIGN UNITS	THIRD ANGLE PROJECTION
		$\nabla_A = 0$ $\nabla_C = 0$ $\nabla_F = 0$	mm	INCH	MM ONLY	1:1	METRIC	
		4 PLACES ± --- ± --- 3 PLACES ± --- ± --- 2 PLACES ± 0.25 ± --- 1 PLACE ± 0.25 ± --- 0 PLACE ± --- ± ---	DRAWN BY: FYANG05 DATE: 2015/06/12 CHECKED BY:		TITLE: VERTICKAL USB A TYPE			
		ANGULAR ± 3 ° DRAFT WHERE APPLICABLE MUST REMAIN WITHIN DIMENSIONS	MATERIAL NO. 1050570005		APPROVED BY: RZHANG DATE: 2015/10/06			
				SIZE A3	THIS DRAWING CONTAINS INFORMATION THAT IS PROPRIETARY TO MOLEX INCORPORATED AND SHOULD NOT BE USED WITHOUT WRITTEN PERMISSION		DOCUMENT NO. SD-105057-005	SHEET NO. 1 OF 1