



FAST CMOS OCTAL D REGISTERS (3-STATE)

IDT54/74FCT574T/AT/CT

FEATURES:

- Std., A, and C grades
- Low input and output leakage $\leq 1\mu\text{A}$ (max.)
- CMOS power levels
- True TTL input and output compatibility:
 - $V_{OH} = 3.3V$ (typ.)
 - $V_{OL} = 0.3V$ (typ.)
- High Drive outputs (-15mA IOH, 48mA IOL)
- Meets or exceeds JEDEC standard 18 specifications
- Military product compliant to MIL-STD-883, Class B and DESC listed (dual marked)
- Power off disable outputs permit "live insertion"
- Available in the following packages:
 - Industrial: SOIC, QSOP
 - Military: CERDIP, LCC

DESCRIPTION:

The FCT574T is an 8-bit register built using an advanced dual metal CMOS technology. These registers consist of eight D-type flip-flops with a buffered common clock and buffered 3-state output control. When the output enable (\overline{OE}) input is low, the eight outputs are enabled. When the \overline{OE} input is high, the outputs are in the high-impedance state.

Input data meeting the set-up and hold time requirements of the D inputs is transferred to the Q outputs on the low-to-high transition of the clock input.

FUNCTIONAL BLOCK DIAGRAM

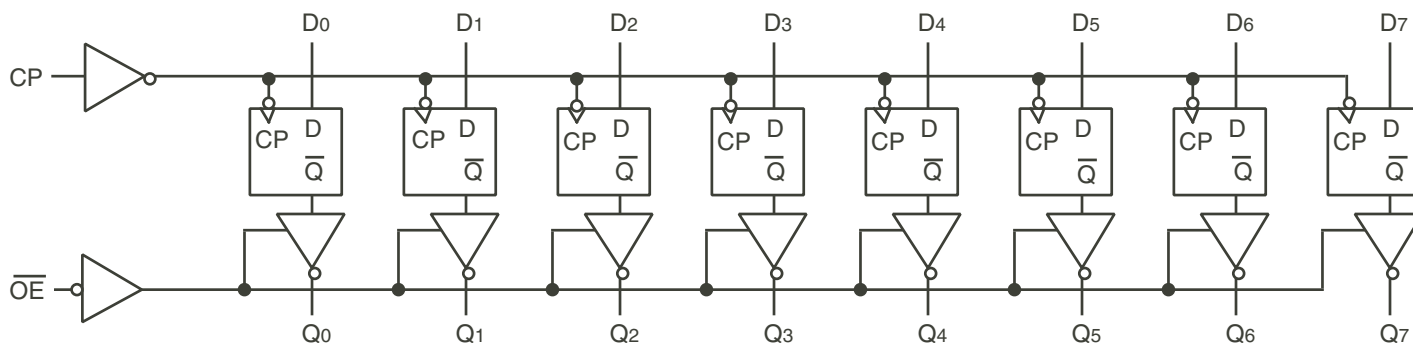

PIN CONFIGURATION

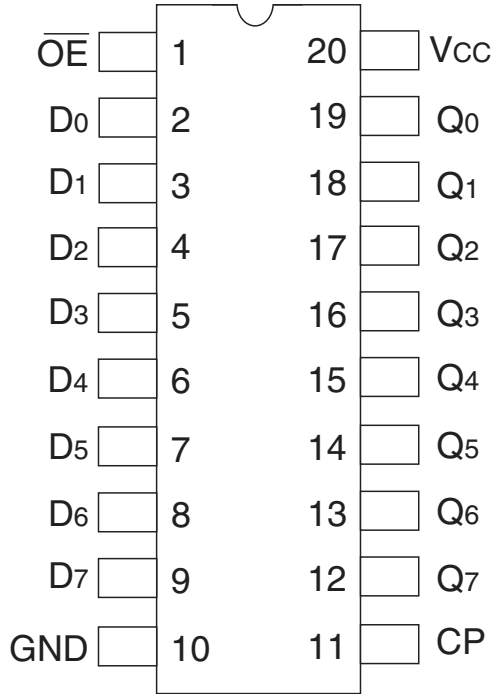

CERDIP/ SOIC/ TSSOP
TOP VIEW

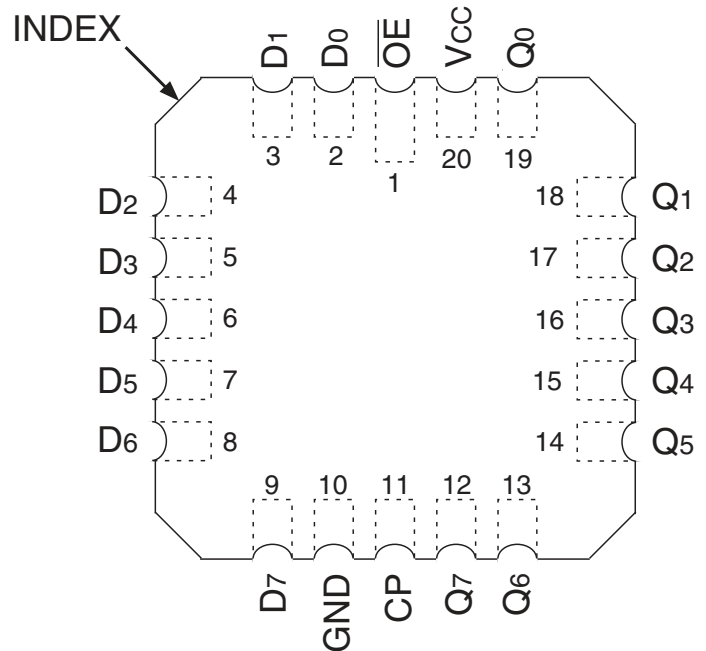

LCC
TOP VIEW

ABSOLUTE MAXIMUM RATINGS⁽¹⁾

Symbol	Description	Max	Unit
VTERM ⁽²⁾	Terminal Voltage with Respect to GND	-0.5 to +7	V
VTERM ⁽³⁾	Terminal Voltage with Respect to GND	-0.5 to Vcc+0.5	V
TSTG	Storage Temperature	-65 to +150	°C
IOUT	DC Output Current	-60 to +120	mA

NOTES:

- Stresses greater than those listed under ABSOLUTE MAXIMUM RATINGS may cause permanent damage to the device. This is a stress rating only and functional operation of the device at these or any other conditions above those indicated in the operational sections of this specification is not implied. Exposure to absolute maximum rating conditions for extended periods may affect reliability. No terminal voltage may exceed Vcc by +0.5V unless otherwise noted.
- Inputs and Vcc terminals only.
- Output and I/O terminals only.

CAPACITANCE (TA = +25°C, F = 1.0MHz)

Symbol	Parameter ⁽¹⁾	Conditions	Typ.	Max.	Unit
CIN	Input Capacitance	VIN = 0V	6	10	pF
COU	Output Capacitance	VOU = 0V	8	12	pF

NOTE:

- This parameter is measured at characterization but not tested.

PIN DESCRIPTION

Pin Names	Description
Dx	D flip-flop data inputs
CP	Clock Pulse for the register. Enters data on LOW-to-HIGH transition.
Qx	3-State Outputs (TRUE)
\bar{Q}_x	3-State Outputs (INVERTED)
\bar{OE}	Active LOW 3-State Output Enable Input

FUNCTION TABLE⁽¹⁾

Function	Inputs			Outputs	Internal
	\bar{OE}	CP	Dx	Qx	\bar{Q}_x
High-Z	H	L	X	Z	NC
	H	H	X	Z	NC
Load Register	L	↑	L	L	H
	L	↑	H	H	L
	H	↑	L	Z	H
	H	↑	H	Z	L

NOTE:

- H = HIGH Voltage Level
X = Don't Care
L = LOW Voltage Level
Z = High Impedance
NC = No Change
↑ = LOW-to-HIGH transition

DC ELECTRICAL CHARACTERISTICS OVER OPERATING RANGE

Following Conditions Apply Unless Otherwise Specified:

Industrial: TA = -40°C to +85°C, VCC = 5.0V ±5%; Military: TA = -55°C to +125°C, VCC = 5.0V ±10%

Symbol	Parameter	Test Conditions ⁽¹⁾		Min.	Typ. ⁽²⁾	Max.	Unit
V _{IH}	Input HIGH Level	Guaranteed Logic HIGH Level		2	—	—	V
V _{IL}	Input LOW Level	Guaranteed Logic LOW Level		—	—	0.8	V
I _{IH}	Input HIGH Current ⁽⁴⁾	V _{CC} = Max.	V _I = 2.7V	—	—	±1	μA
I _{IL}	Input LOW Current ⁽⁴⁾	V _{CC} = Max.	V _I = 0.5V	—	—	±1	μA
I _{OZH}	High Impedance Output Current (3-State output pins) ⁽⁴⁾	V _{CC} = Max	V _O = 2.7V	—	—	±1	μA
I _{OZL}			V _O = 0.5V	—	—	±1	
I _I	Input HIGH Current ⁽⁴⁾	V _{CC} = Max., V _I = V _{CC} (Max.)		—	—	±1	μA
V _{IK}	Clamp Diode Voltage	V _{CC} = Min, I _{IN} = -18mA		—	-0.7	-1.2	V
V _H	Input Hysteresis	—		—	200	—	mV
I _{CC}	Quiescent Power Supply Current	V _{CC} = Max., V _{IN} = GND or V _{CC}		—	0.01	1	mA

OUTPUT DRIVE CHARACTERISTICS

Symbol	Parameter	Test Conditions ⁽¹⁾		Min.	Typ. ⁽²⁾	Max.	Unit
V _{OH}	Output HIGH Voltage	V _{CC} = Min V _{IN} = V _{IH} or V _{IL}	I _{OH} = -6mA MIL	2.4	3.3	—	V
			I _{OH} = -8mA IND	—	—	—	
V _{OL}	Output LOW Voltage	V _{CC} = Min V _{IN} = V _{IH} or V _{IL}	I _{OH} = -12mA MIL	2	3	—	V
			I _{OH} = -15mA IND	—	—	—	
I _{OL}	Output LOW Current	V _{CC} = Min V _{IN} = V _{IH} or V _{IL}	I _{OL} = 32mA MIL	—	0.3	0.5	mA
			I _{OL} = 48mA IND	—	—	—	
I _{OS}	Short Circuit Current	V _{CC} = Max., V _O = GND ⁽³⁾		-60	-120	-225	mA

NOTES:

1. For conditions shown as Min. or Max., use appropriate value specified under Electrical Characteristics for the applicable device type.
2. Typical values are at V_{CC} = 5.0V, +25°C ambient.
3. Not more than one output should be tested at one time. Duration of the test should not exceed one second.
4. The test limit for this parameter is ±5μA at TA = -55°C.

POWER SUPPLY CHARACTERISTICS

Symbol	Parameter	Test Conditions ⁽¹⁾		Min.	Typ. ⁽²⁾	Max.	Unit
ΔI_{CC}	Quiescent Power Supply Current TTL Inputs HIGH	$V_{CC} = \text{Max.}$ $V_{IN} = 3.4V^{(3)}$		—	0.5	2	mA
I_{CCD}	Dynamic Power Supply Current ⁽⁴⁾	$V_{CC} = \text{Max.}$ Outputs Open $\overline{OE} = \text{GND}$ One Input Toggling 50% Duty Cycle	$V_{IN} = V_{CC}$ $V_{IN} = \text{GND}$	—	0.15	0.25	mA/ MHz
I_C	Total Power Supply Current ⁽⁶⁾	$V_{CC} = \text{Max.}$ Outputs Open $f_{CP} = 10\text{MHz}$ 50% Duty Cycle $\overline{OE} = \text{GND}$ $f_i = 5\text{MHz}$ One Bit Toggling	$V_{IN} = V_{CC}$ $V_{IN} = \text{GND}$	—	1.5	3.5	mA
			$V_{IN} = 3.4V$ $V_{IN} = \text{GND}$	—	2	5.5	
		$V_{CC} = \text{Max.}$ Outputs Open $f_{CP} = 10\text{MHz}$ 50% Duty Cycle $\overline{OE} = \text{GND}$ Eight Bits Toggling $f_i = 2.5\text{MHz}$	$V_{IN} = V_{CC}$ $V_{IN} = \text{GND}$	—	3.8	7.3 ⁽⁵⁾	mA
			$V_{IN} = 3.4V$ $V_{IN} = \text{GND}$	—	6	16.3 ⁽⁵⁾	

NOTES:

- For conditions shown as Min. or Max., use appropriate value specified under Electrical Characteristics for the applicable device type.
- Typical values are at $V_{CC} = 5.0V$, $+25^\circ\text{C}$ ambient.
- Per TTL driven input; ($V_{IN} = 3.4V$). All other inputs at V_{CC} or GND .
- This parameter is not directly testable, but is derived for use in Total Power Supply Calculations.
- Values for these conditions are examples of ΔI_{CC} formula. These limits are guaranteed but not tested.
- $I_C = I_{QUIESCENT} + I_{INPUTS} + I_{DYNAMIC}$
 $I_C = I_{CC} + \Delta I_{CC} D_H N_T + I_{CCD} (f_{CP}/2 + f_i N_i)$
 $I_{CC} = \text{Quiescent Current}$
 $\Delta I_{CC} = \text{Power Supply Current for a TTL High Input } (V_{IN} = 3.4V)$
 $D_H = \text{Duty Cycle for TTL Inputs High}$
 $N_T = \text{Number of TTL Inputs at } D_H$
 $I_{CCD} = \text{Dynamic Current caused by an Input Transition Pair (HLH or LHL)}$
 $f_{CP} = \text{Clock Frequency for Register Devices (Zero for Non-Register Devices)}$
 $f_i = \text{Output Frequency}$
 $N_i = \text{Number of Outputs at } f_i$

All currents are in milliamps and all frequencies are in megahertz.

SWITCHING CHARACTERISTICS OVER OPERATING RANGE - INDUSTRIAL

Symbol	Parameter	Condition ⁽¹⁾	FCT574AT		FCT574CT		Unit
			Min. ⁽²⁾	Max.	Min. ⁽²⁾	Max.	
t _{PLH} t _{PHL}	Propagation Delay CP to Qx	CL = 50pF RL = 500Ω	2	6.5	2	5.2	ns
t _{PZH} t _{PZL}	Output Enable Time		1.5	6.5	1.5	5.5	ns
t _{PHZ} t _{PLZ}	Output Disable Time		1.5	5.5	1.5	5	ns
t _{SU}	Set-up Time, HIGH or LOW Dx to CP		2	—	2	—	ns
t _H	Hold Time, HIGH or LOW Dx to CP		1.5	—	1.5	—	ns
t _w	CP Pulse Width HIGH or LOW ⁽³⁾		5	—	5	—	ns

SWITCHING CHARACTERISTICS OVER OPERATING RANGE - MILITARY

Symbol	Parameter	Condition ⁽¹⁾	FCT574T		FCT574AT		FCT574CT		Unit
			Min. ⁽²⁾	Max.	Min. ⁽²⁾	Max.	Min. ⁽²⁾	Max.	
t _{PLH} t _{PHL}	Propagation Delay CP to Qx	CL = 50pF RL = 500Ω	2	11	2	7.2	2	6.2	ns
t _{PZH} t _{PZL}	Output Enable Time		1.5	14	1.5	7.5	1.5	6.2	ns
t _{PHZ} t _{PLZ}	Output Disable Time		1.5	8	1.5	6.5	1.5	5.7	ns
t _{SU}	Set-up Time, HIGH or LOW Dx to CP		2	—	2	—	2	—	ns
t _H	Hold Time, HIGH or LOW Dx to CP		1.5	—	1.5	—	1.5	—	ns
t _w	CP Pulse Width HIGH or LOW ⁽³⁾		7	—	6	—	6	—	ns

NOTES:

1. See test circuit and waveforms.
2. Minimum limits are guaranteed but not tested on Propagation Delays.
3. This limit is guaranteed but not tested.

TEST CIRCUITS AND WAVEFORMS

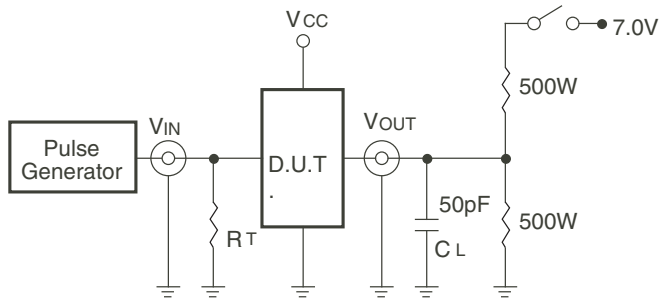

Octal Link

Test Circuits for All Outputs

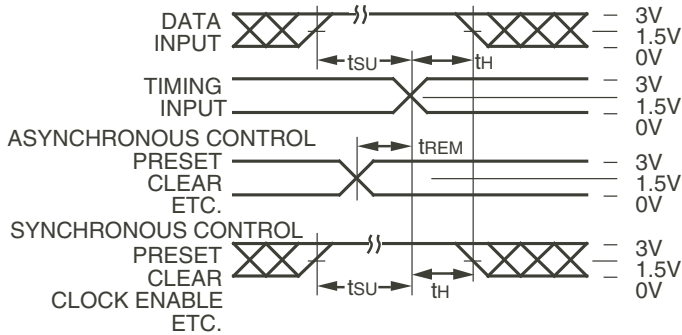

Octal Link

Set-Up, Hold, and Release Times

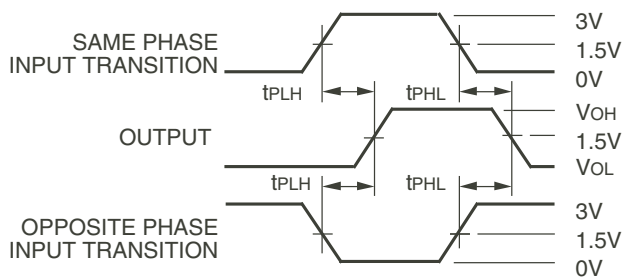

Octal Link

Propagation Delay

SWITCH POSITION

Test	Switch
Open Drain Disable Low Enable Low	Closed
All Other Tests	Open

DEFINITIONS:

C_L = Load capacitance: includes jig and probe capacitance.

R_T = Termination resistance: should be equal to Z_{OUT} of the Pulse Generator.

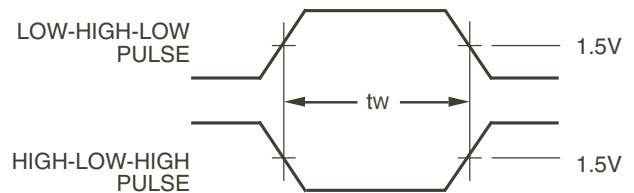

Pulse Width

Octal Link

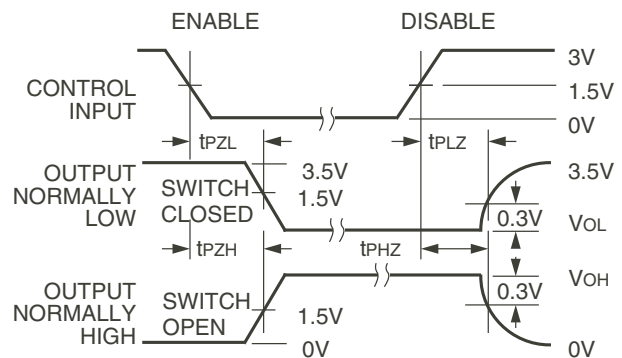

Octal Link

Enable and Disable Times

NOTES:

- Diagram shown for input Control Enable-LOW and input Control Disable-HIGH.
- Pulse Generator for All Pulses: Rate $\leq 1.0\text{MHz}$; $t_r \leq 2.5\text{ns}$; $t_f \leq 2.5\text{ns}$.

ORDERING INFORMATION

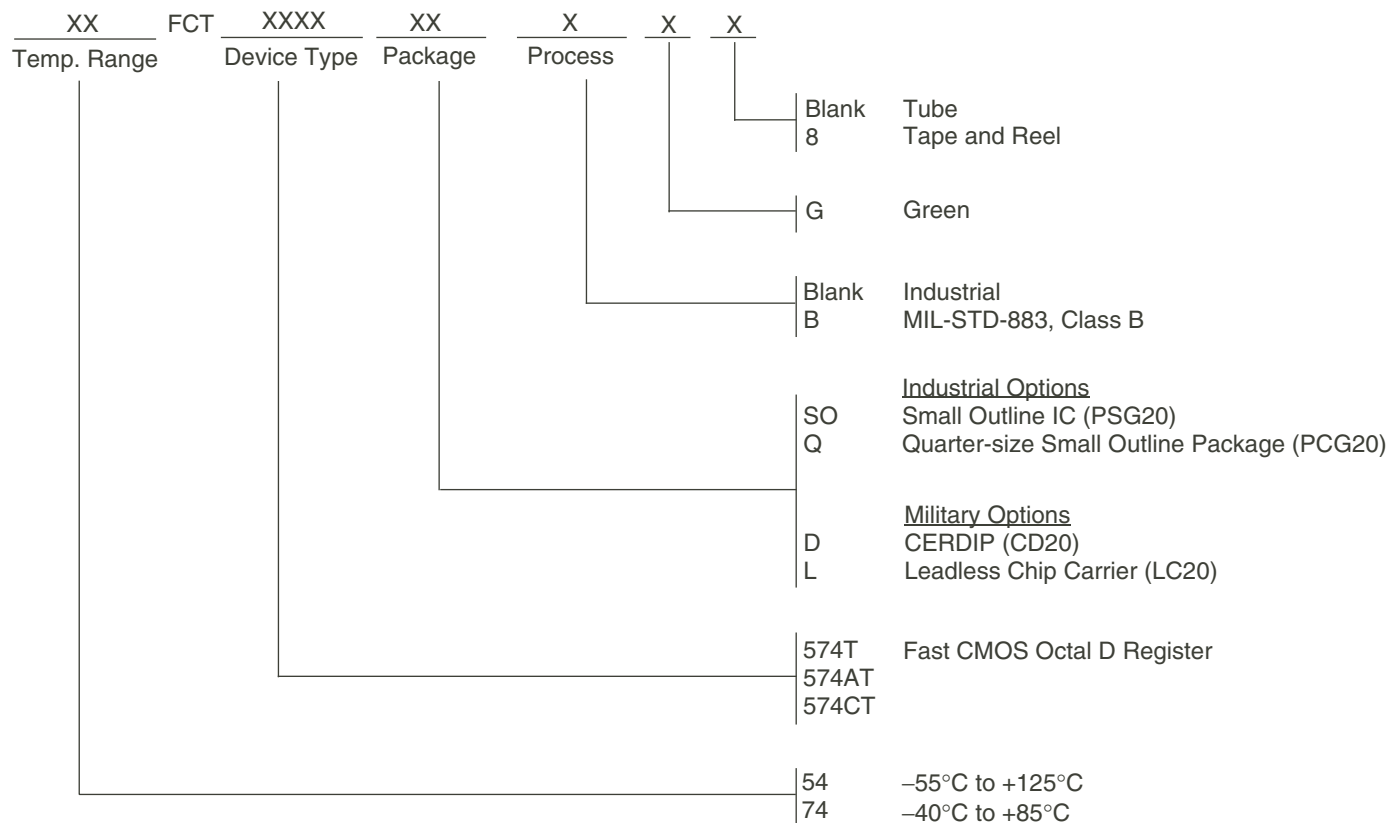

Datasheet Document History

10/10/2009	Pg. 7	Updated the ordering information by removing the "IDT" notation and non RoHS part.
11/17/2016	Pg. 7	Updated the ordering information by adding detailed package information and Tape & Reel.



CORPORATE HEADQUARTERS
6024 Silver Creek Valley Road
San Jose, CA 95138

for SALES:
800-345-7015 or 408-284-8200
fax: 408-284-2775
www.idt.com

for Tech Support:
logichelp@idt.com