

- ① MATERIAL: STAINLESS STEEL.
- ② MATERIAL: BRASS.
- ③ FINISH: PASSIVATE.
- ④ FINISH: 0.00038-0.00102 [.000150-.000400] NICKEL PLATE.
- ⑤ PART NUMBER IS OBSOLETE.

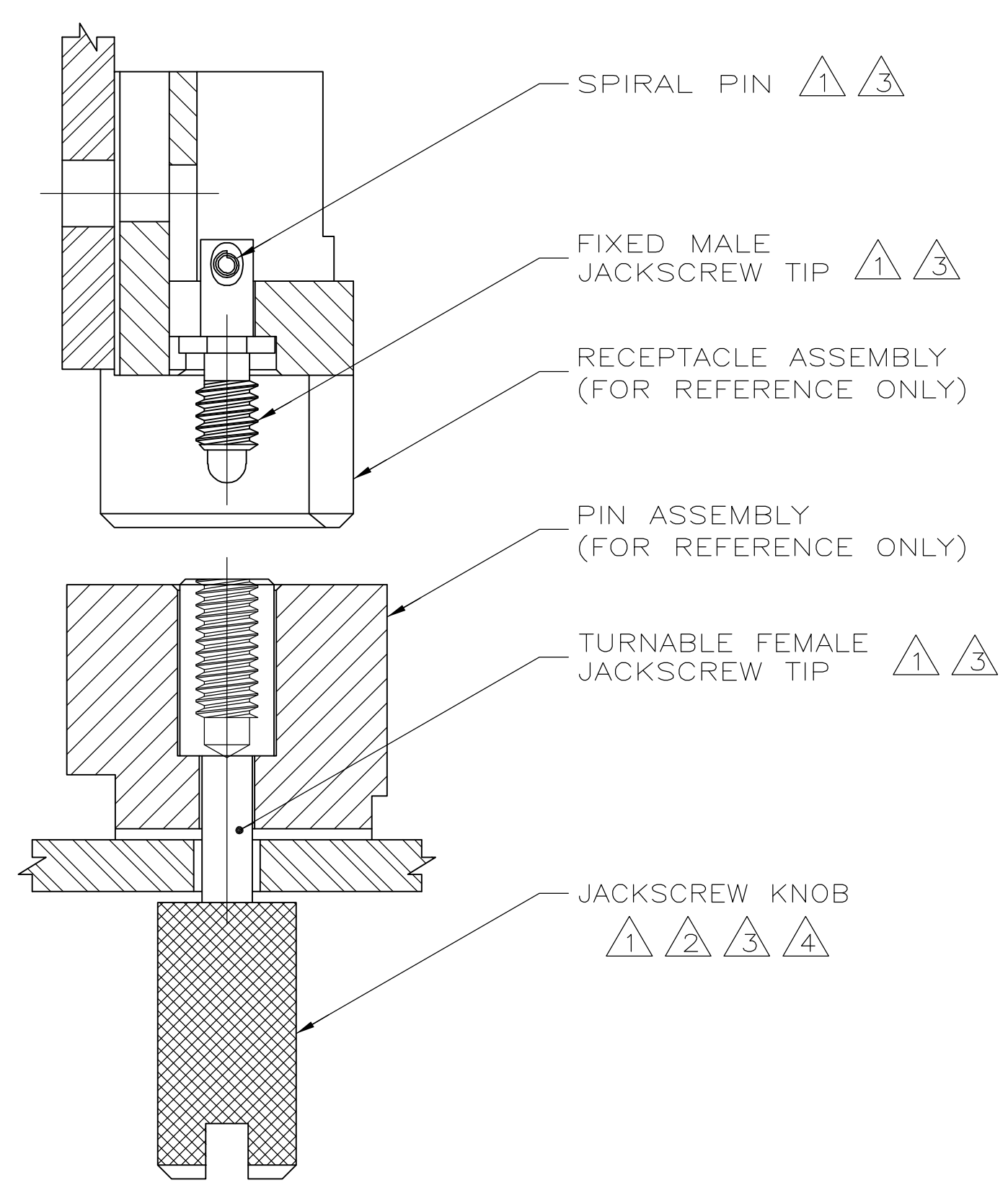
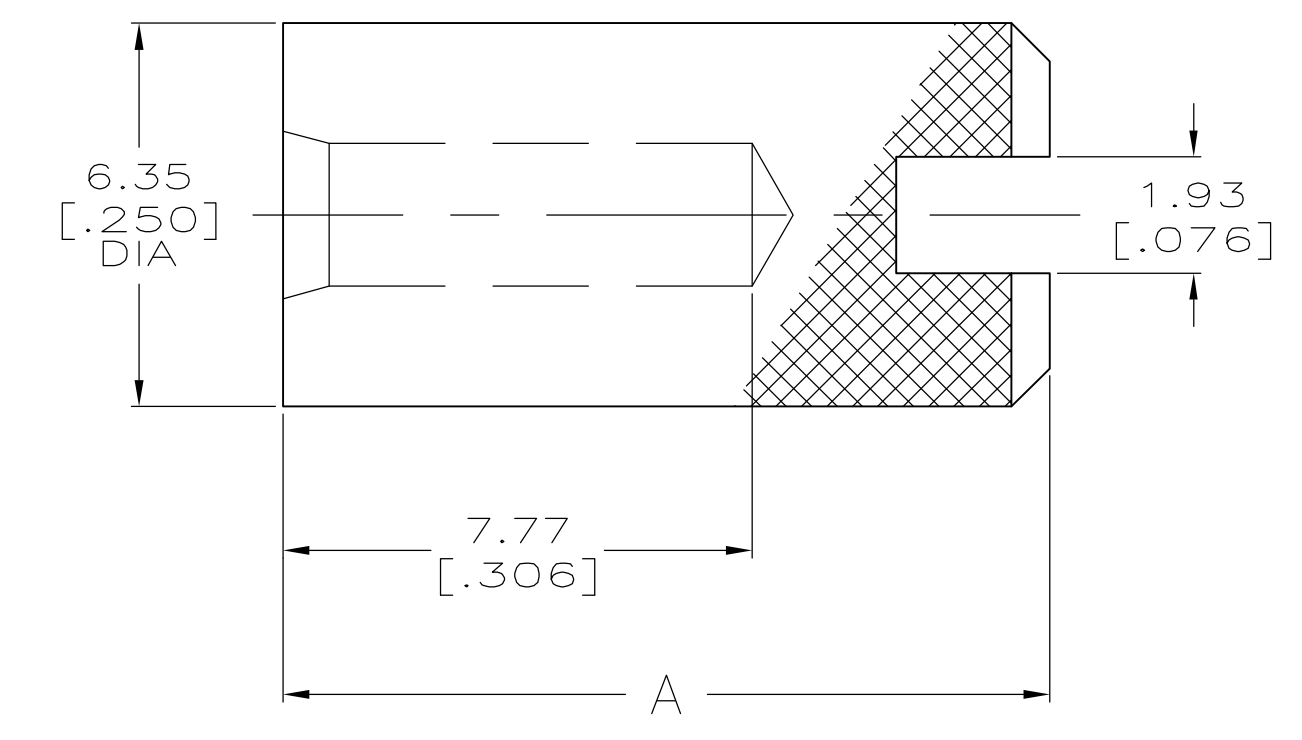
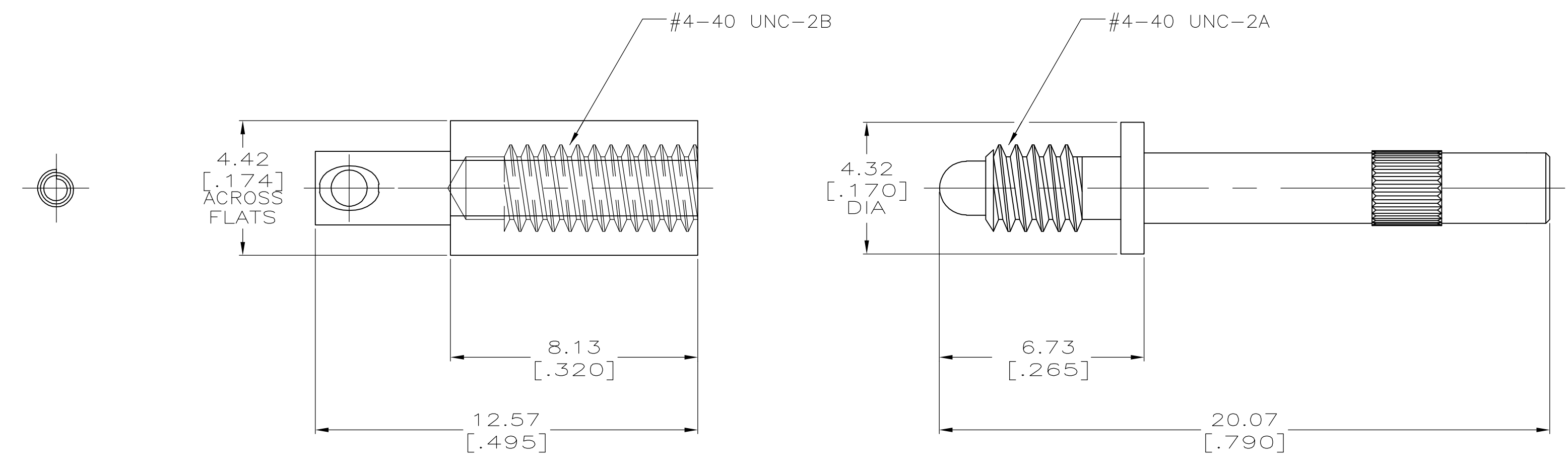

⑤	---	---	---	---	532805-8
⑤	---	---	---	---	532805-7
⑤	---	---	---	---	532805-6
⑤	---	---	---	---	532805-5
⑤	YES	③	①	3.18 [1.250]	532805-4
⑤	YES	③	①	1.27 [.500]	532805-3
⑤	NO	③	①	1.27 [.500]	532805-2
⑤	-	③	①	-	532805-1
	SLOT FOR SCREWDRIVER	FINISH	MATERIAL	A	PART NUMBER

THIS DRAWING IS A CONTROLLED DOCUMENT.		DWN R.K. SEIFRIED 1-31-94	Tyco Electronics Corporation Harrisburg, PA 17105-3608	
DIMENSIONS: mm [INCHES]		CHK G. SKIPPER	NAME	
TOLERANCES UNLESS OTHERWISE SPECIFIED:		PRODUCT SPEC		
0 PLC ± -		APPLICATION SPEC		
1 PLC ± -		SIZE		
2 PLC ± -		CAGE CODE		
3 PLC ± .005		DRAWING NO		
4 PLC ± -		RESTRICTED TO		
ANGLES ± -		WEIGHT		
FINISH		A1 00779 ©=532805		
MATERIAL		CUSTOMER DRAWING		