

ADP1111

FEATURES

- Operates from 2 V to 30 V Input Voltage Range
- 72 kHz Frequency Operation
- Utilizes Surface Mount Inductors
- Very Few External Components Required
- Operates in Step-Up/Step-Down or Inverting Mode
- Low Battery Detector
- User Adjustable Current Limit
- Internal 1 A Power Switch
- Fixed or Adjustable Output Voltage
- 8-Pin DIP or SO-8 Package

APPLICATIONS

- 3 V to 5 V, 5 V to 12 V Step-Up Converters
- 9 V to 5 V, 12 V to 5 V Step-Down Converters
- Laptop and Palmtop Computers
- Cellular Telephones
- Flash Memory VPP Generators
- Remote Controls
- Peripherals and Add-On Cards
- Battery Backup Supplies
- Uninterruptible Supplies
- Portable Instruments

GENERAL DESCRIPTION

The ADP1111 is part of a family of step-up/step-down switching regulators that operates from an input voltage supply of 2 V to 12 V in step-up mode and up to 30 V in step-down mode. The ADP1111 can be programmed to operate in step-up/step-down or inverting applications with only 3 external components.

The fixed outputs are 3.3 V, 5 V and 12 V; and an adjustable version is also available. The ADP1111 can deliver 100 mA at 5 V from a 3 V input in step-up mode, or it can deliver 200 mA at 5 V from a 12 V input in step-down mode.

FUNCTIONAL BLOCK DIAGRAMS

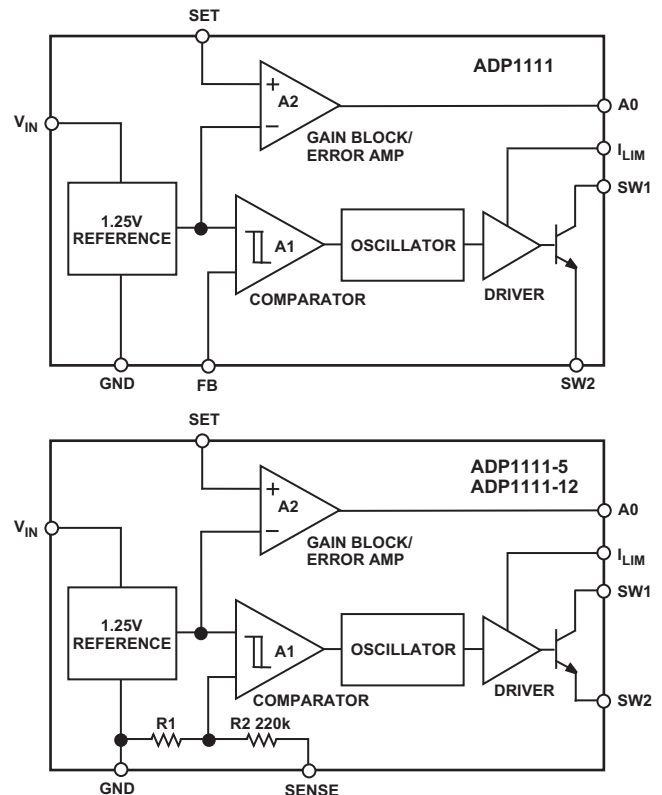

Maximum switch current can be programmed with a single resistor, and an open collector gain block can be arranged in multiple configuration for low battery detection, as a post linear regulator, undervoltage lockout, or as an error amplifier.

If input voltages are lower than 2 V, see the ADP1110.

REV. A

Information furnished by Analog Devices is believed to be accurate and reliable. However, no responsibility is assumed by Analog Devices for its use, nor for any infringements of patents or other rights of third parties which may result from its use. No license is granted by implication or otherwise under any patent or patent rights of Analog Devices.

ADP1111—SPECIFICATIONS ($0^{\circ}\text{C} \leq T_A \leq +70^{\circ}\text{C}$, $V_{\text{IN}} = 3\text{ V}$ unless otherwise noted)

Parameter	Conditions	V_S	Min	Typ	Max	Units
QUIESCENT CURRENT	Switch Off	I_Q		300	500	μA
INPUT VOLTAGE	Step-Up Mode Step-Down Mode	V_{IN}	2.0		12.6 30.0	V V
COMPARATOR TRIP POINT VOLTAGE	ADP1111 ¹		1.20	1.25	1.30	V
OUTPUT SENSE VOLTAGE	ADP1111-3.3 ADP1111-5 ² ADP1111-12 ²	V_{OUT}	3.13 4.75 11.40	3.30 5.00 12.00	3.47 5.25 12.60	V V V
COMPARATOR HYSTERESIS	ADP1111			8	12.5	mV
OUTPUT HYSTERESIS	ADP1111-3.3 ADP1111-5 ADP1111-12			21 32 75	50 50 120	mV mV mV
OSCILLATOR FREQUENCY		f_{OSC}	54	72	88	kHz
DUTY CYCLE	Full Load	DC	43	50	65	%
SWITCH ON TIME	I_{LIM} Tied to V_{IN}	t_{ON}	5	7	9	μs
SW SATURATION VOLTAGE STEP-UP MODE	$T_A = +25^{\circ}\text{C}$ $V_{\text{IN}} = 3.0\text{ V}$, $I_{\text{SW}} = 650\text{ mA}$	V_{SAT}		0.5	0.65	V
STEP-DOWN MODE	$V_{\text{IN}} = 5.0\text{ V}$, $I_{\text{SW}} = 1\text{ A}$ $V_{\text{IN}} = 12\text{ V}$, $I_{\text{SW}} = 650\text{ mA}$			0.8 1.1	1.0 1.5	V V
FEEDBACK PIN BIAS CURRENT	ADP1111 $V_{\text{FB}} = 0\text{ V}$	I_{FB}		160	300	nA
SET PIN BIAS CURRENT	$V_{\text{SET}} = V_{\text{REF}}$	I_{SET}		270	400	nA
GAIN BLOCK OUTPUT LOW	$I_{\text{SINK}} = 300\text{ }\mu\text{A}$ $V_{\text{SET}} = 1.00\text{ V}$	V_{OL}		0.15	0.4	V
REFERENCE LINE REGULATION	$5\text{ V} \leq V_{\text{IN}} \leq 30\text{ V}$ $2\text{ V} \leq V_{\text{IN}} \leq 5\text{ V}$			0.02 0.4	0.075	%/V %/V
GAIN BLOCK GAIN	$R_L = 100\text{ k}\Omega^3$	A_V	1000	6000		V/V
CURRENT LIMIT	$T_A = +25^{\circ}\text{C}$ 220 Ω from I_{LIM} to V_{IN}	I_{LIM}		400		mA
CURRENT LIMIT TEMPERATURE COEFFICIENT				-0.3		%/ $^{\circ}\text{C}$
SWITCH OFF LEAKAGE CURRENT	$T_A = +25^{\circ}\text{C}$ Measured at SW1 Pin $V_{\text{SW1}} = 12\text{ V}$			1	10	μA
MAXIMUM EXCURSION BELOW GND	$T_A = +25^{\circ}\text{C}$ $I_{\text{SW1}} \leq 10\text{ }\mu\text{A}$, Switch Off			-400	-350	mV

NOTES

¹This specification guarantees that both the high and low trip points of the comparator fall within the 1.20 V to 1.30 V range.

²The output voltage waveform will exhibit a sawtooth shape due to the comparator hysteresis. The output voltage on the fixed output versions will always be within the specified range.

³100 k Ω resistor connected between a 5 V source and the AO pin.

⁴All limits at temperature extremes are guaranteed via correlation using standard statistical methods.

Specifications subject to change without notice.

ABSOLUTE MAXIMUM RATINGS

Parameter	Rating
Supply Voltage	36 V
SW1 Pin Voltage	50 V
SW2 Pin Voltage	-0.5 V to V_{IN}
Feedback Pin Voltage (ADP1111)	5.5 V
Switch Current	1.5 A
Maximum Power Dissipation	500 mW
Operating Temperature Range	
ADP1111A	0°C to 70°C
Storage Temperature Range	-65°C to +150°C
Lead Temperature (Soldering, 10 sec)	300°C

TYPICAL APPLICATION

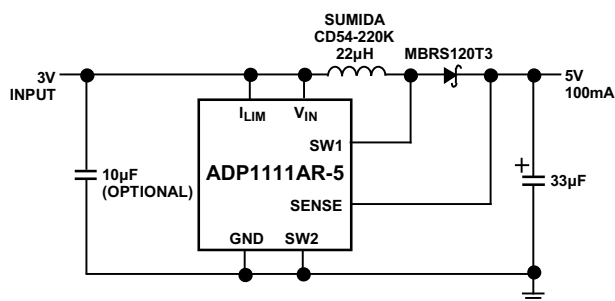

Figure 1. 3 V to 5 V Step-Up Converter

PIN DESCRIPTIONS

Mnemonic	Function
I_{LIM}	For normal conditions this pin is connected to V_{IN} . When lower current is required, a resistor should be connected between I_{LIM} and V_{IN} . Limiting the switch current to 400 mA is achieved by connecting a 220 Ω resistor.
V_{IN}	Input Voltage.
SW1	Collector Node of Power Transistor. For step-down configuration, connect to V_{IN} . For step-up configuration, connect to an inductor/diode.
SW2	Emitter Node of Power Transistor. For step-down configuration, connect to inductor/diode. For step-up configuration, connect to ground. Do not allow this pin to go more than a diode drop below ground.
GND	Ground.
AO	Auxiliary Gain (GB) Output. The open collector can sink 300 μ A. It can be left open if unused.
SET	Gain Amplifier Input. The amplifier's positive input is connected to SET pin and its negative input is connected to the 1.25 V reference. It can be left open if unused.
FB/SENSE	On the ADP1111 (adjustable) version this pin is connected to the comparator input. On the ADP1111-3.3, ADP1111-5 and ADP1111-12, the pin goes directly to the internal application resistor that sets output voltage.

ESD CAUTION



ESD (electrostatic discharge) sensitive device. Charged devices and circuit boards can discharge without detection. Although this product features patented or proprietary protection circuitry, damage may occur on devices subjected to high energy ESD. Therefore, proper ESD precautions should be taken to avoid performance degradation or loss of functionality.

PIN CONFIGURATIONS

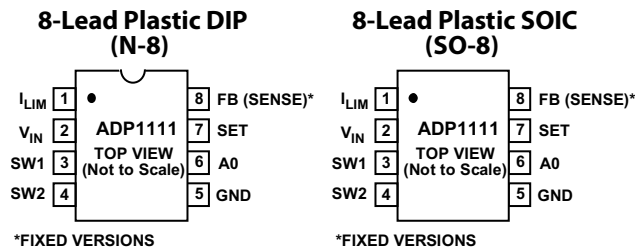

ADP1111–Typical Characteristics

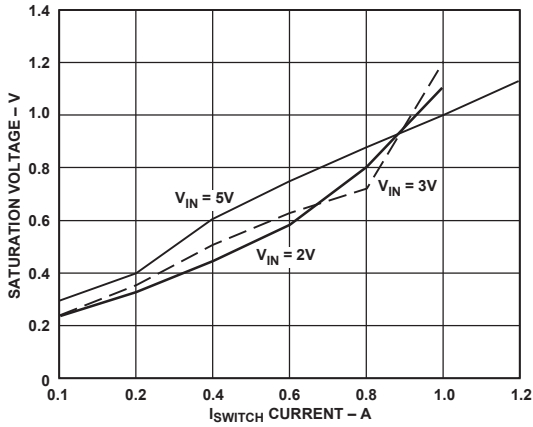

Figure 2. Saturation Voltage vs. I_{SWITCH} Current in Step-Up Mode

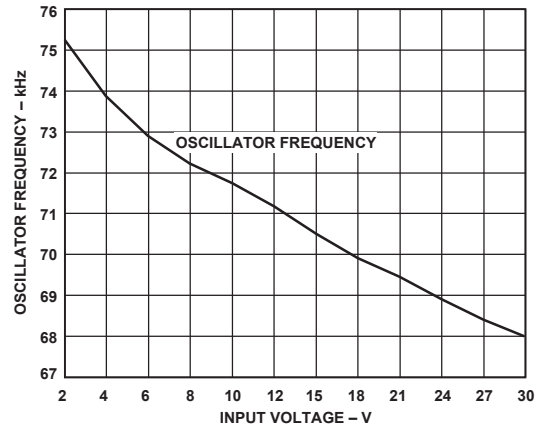

Figure 5. Oscillator Frequency vs. Input Voltage

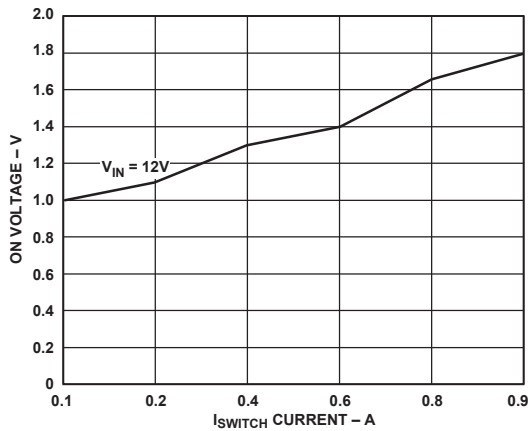

Figure 3. Switch ON Voltage vs. I_{SWITCH} Current in Step-Down Mode

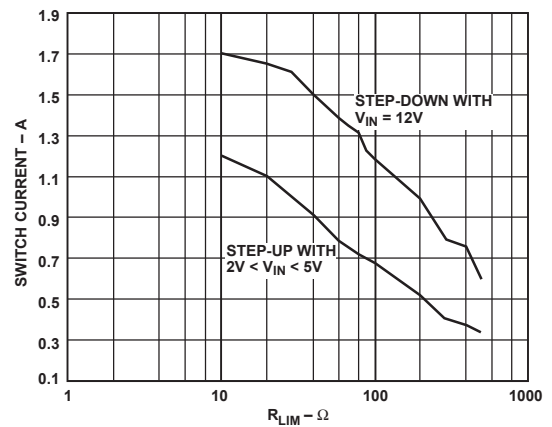

Figure 6. Maximum Switch Current vs. R_{LIM}

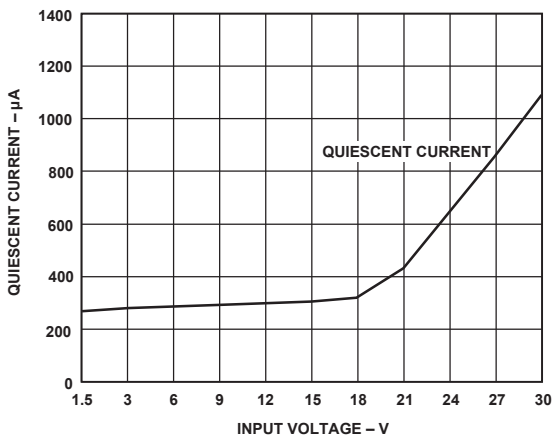

Figure 4. Quiescent Current vs. Input Voltage

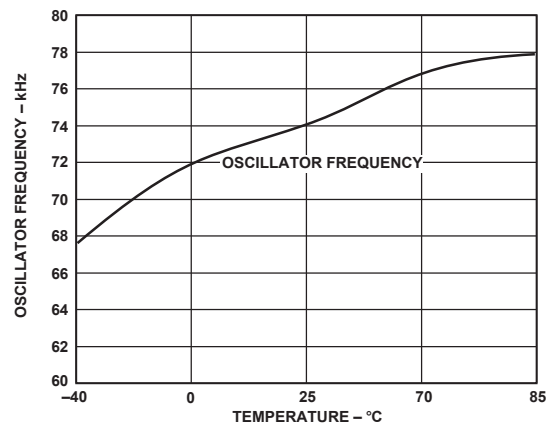

Figure 7. Oscillator Frequency vs. Temperature

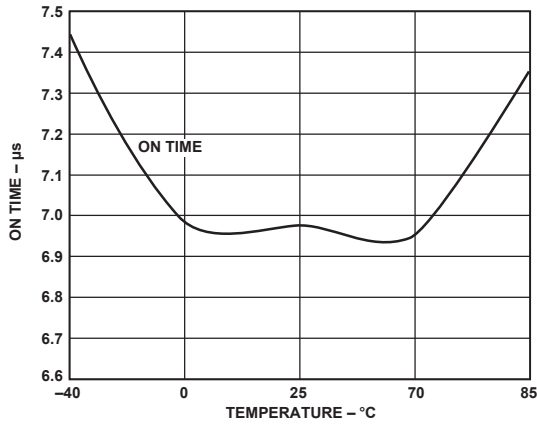

Figure 8. Switch ON Time vs. Temperature

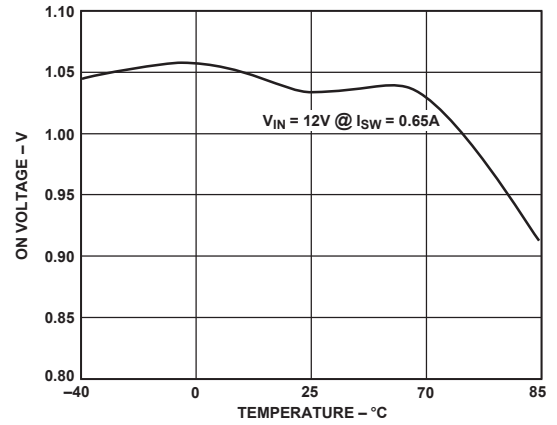

Figure 11. Switch ON Voltage vs. Temperature in Step-Down Mode

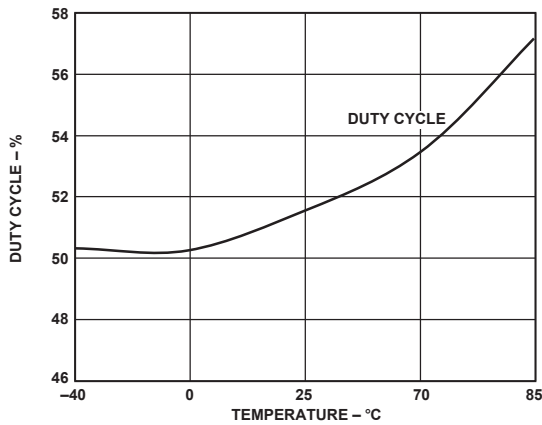

Figure 9. Duty Cycle vs. Temperature

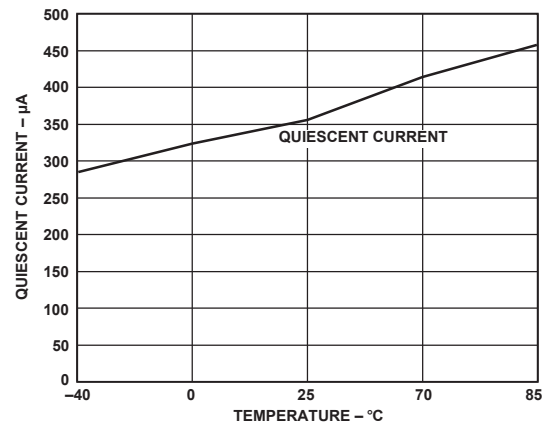

Figure 12. Quiescent Current vs. Temperature

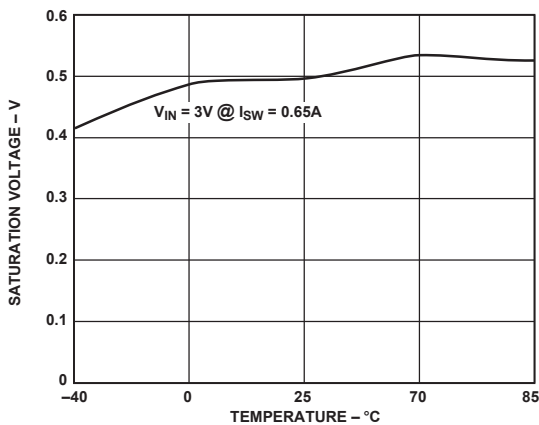

Figure 10. Saturation Voltage vs. Temperature in Step-Up Mode

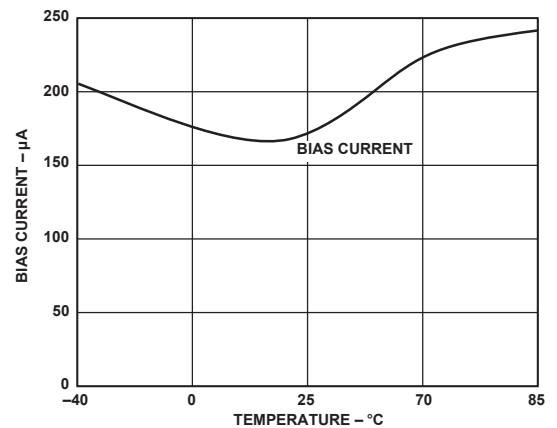

Figure 13. Feedback Bias Current vs. Temperature

ADP1111

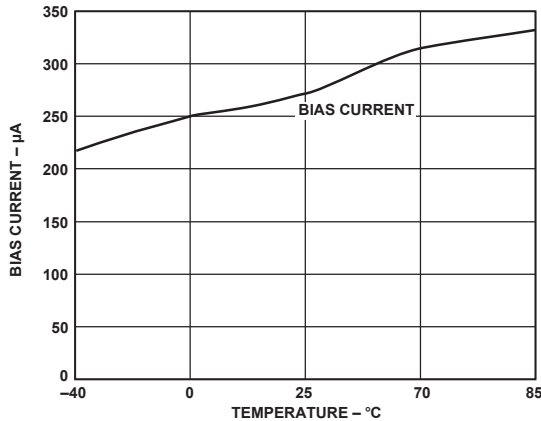

Figure 14. Set Pin Bias Current vs. Temperature

THEORY OF OPERATION

The ADP1111 is a flexible, low-power, switch-mode power supply (SMPS) controller. The regulated output voltage can be greater than the input voltage (boost or step-up mode) or less than the input (buck or step-down mode). This device uses a gated-oscillator technique to provide very high performance with low quiescent current.

A functional block diagram of the ADP1111 is shown on the first page of this data sheet. The internal 1.25 V reference is connected to one input of the comparator, while the other input is externally connected (via the FB pin) to a feedback network connected to the regulated output. When the voltage at the FB pin falls below 1.25 V, the 72 kHz oscillator turns on. A driver amplifier provides base drive to the internal power switch, and the switching action raises the output voltage. When the voltage at the FB pin exceeds 1.25 V, the oscillator is shut off. While the oscillator is off, the ADP1111 quiescent current is only 300 µA. The comparator includes a small amount of hysteresis, which ensures loop stability without requiring external components for frequency compensation.

The maximum current in the internal power switch can be set by connecting a resistor between V_{IN} and the I_{LIM} pin. When the maximum current is exceeded, the switch is turned OFF. The current limit circuitry has a time delay of about 1 µs. If an external resistor is not used, connect I_{LIM} to V_{IN} . Further information on I_{LIM} is included in the “APPLICATIONS” section of this data sheet.

The ADP1111 internal oscillator provides 7 µs ON and 7 µs OFF times that are ideal for applications where the ratio between V_{IN} and V_{OUT} is roughly a factor of two (such as converting +3 V to +5 V). However, wider range conversions (such as generating +12 V from a +5 V supply) can easily be accomplished.

An uncommitted gain block on the ADP1111 can be connected as a low-battery detector. The inverting input of the gain block is internally connected to the 1.25 V reference. The noninverting input is available at the SET pin. A resistor divider, connected between V_{IN} and GND with the junction connected to the SET pin, causes the AO output to go LOW when the low battery set point is exceeded. The AO output is an open collector NPN transistor that can sink 300 µA.

The ADP1111 provides external connections for both the collector and emitter of its internal power switch that permit both step-up and step-down modes of operation. For the step-up mode, the emitter (Pin SW2) is connected to GND, and the collector (Pin SW1) drives the inductor. For step-down mode, the emitter drives the inductor while the collector is connected to V_{IN} .

The output voltage of the ADP1111 is set with two external resistors. Three fixed-voltage models are also available: ADP1111-3.3 (+3.3 V), ADP1111-5 (+5 V) and ADP1111-12 (+12 V). The fixed-voltage models are identical to the ADP1111, except that laser-trimmed voltage-setting resistors are included on the chip. On the fixed-voltage models of the ADP1111, simply connect the feedback pin (Pin 8) directly to the output voltage.

COMPONENT SELECTION

General Notes on Inductor Selection

When the ADP1111 internal power switch turns on, current begins to flow in the inductor. Energy is stored in the inductor core while the switch is on, and this stored energy is transferred to the load when the switch turns off. Since both the collector and the emitter of the switch transistor are accessible on the ADP1111, the output voltage can be higher, lower, or of opposite polarity than the input voltage.

To specify an inductor for the ADP1111, the proper values of inductance, saturation current and dc resistance must be determined. This process is not difficult, and specific equations for each circuit configuration are provided in this data sheet. In general terms, however, the inductance value must be low enough to store the required amount of energy (when both input voltage and switch ON time are at a minimum) but high enough that the inductor will not saturate when both V_{IN} and switch ON time are at their maximum values. The inductor must also store enough energy to supply the load, without saturating. Finally, the dc resistance of the inductor should be low so that excessive power will not be wasted by heating the windings. For most ADP1111 applications, an inductor of 15 µH to 100 µH with a saturation current rating of 300 mA to 1 A and dc resistance <0.4 Ω is suitable. Ferrite-core inductors that meet these specifications are available in small, surface-mount packages.

To minimize Electro-Magnetic Interference (EMI), a toroid or pot-core type inductor is recommended. Rod-core inductors are a lower-cost alternative if EMI is not a problem.

CALCULATING THE INDUCTOR VALUE

Selecting the proper inductor value is a simple three step process:

1. Define the operating parameters: minimum input voltage, maximum input voltage, output voltage and output current.
2. Select the appropriate conversion topology (step-up, step-down, or inverting).
3. Calculate the inductor value using the equations in the following sections.

INDUCTOR SELECTION-STEP-UP CONVERTER

In a step-up or boost converter (Figure 18), the inductor must store enough power to make up the difference between the input voltage and the output voltage. The power that must be stored is calculated from the equation:

$$P_L = (V_{OUT} + V_D - V_{IN(MIN)}) \cdot (I_{OUT}) \quad (\text{Equation 1})$$

where V_D is the diode forward voltage (0.5 V for a 1N5818 Schottky). Because energy is only stored in the inductor while the ADP1111 switch is ON, the energy stored in the inductor on each switching cycle must be equal to or greater than:

$$\frac{P_L}{f_{OSC}} \quad (\text{Equation 2})$$

in order for the ADP1111 to regulate the output voltage.

When the internal power switch turns ON, current flow in the inductor increases at the rate of:

$$I_L(t) = \frac{V_{IN}}{R'} \left(1 - e^{-\frac{Rt}{L}} \right) \quad (\text{Equation 3})$$

where L is in Henrys and R' is the sum of the switch equivalent resistance (typically 0.8 Ω at +25°C) and the dc resistance of the inductor. In most applications, the voltage drop across the switch is small compared to V_{IN} so a simpler equation can be used:

$$I_L(t) = \frac{V_{IN}}{L} t \quad (\text{Equation 4})$$

Replacing ' t ' in the above equation with the ON time of the ADP1111 (7 μ s, typical) will define the peak current for a given inductor value and input voltage. At this point, the inductor energy can be calculated as follows:

$$E_L = \frac{1}{2} L \cdot I^2_{PEAK} \quad (\text{Equation 5})$$

As previously mentioned, E_L must be greater than P_L/f_{OSC} so that the ADP1111 can deliver the necessary power to the load. For best efficiency, peak current should be limited to 1 A or less. Higher switch currents will reduce efficiency because of increased saturation voltage in the switch. High peak current also increases output ripple. As a general rule, keep peak current as low as possible to minimize losses in the switch, inductor and diode.

In practice, the inductor value is easily selected using the equations above. For example, consider a supply that will generate 12 V at 40 mA from a 9 V battery, assuming a 6 V end-of-life voltage. The inductor power required is, from Equation 1:

$$P_L = (12 V + 0.5 V - 6 V) \cdot (40 mA) = 260 mW$$

On each switching cycle, the inductor must supply:

$$\frac{P_L}{f_{OSC}} = \frac{260 mW}{72 kHz} = 3.6 \mu J$$

Since the required inductor power is fairly low in this example, the peak current can also be low. Assuming a peak current of 500 mA as a starting point, Equation 4 can be rearranged to recommend an inductor value:

$$L = \frac{V_{IN}}{I_{L(MAX)}} t = \frac{6 V}{500 mA} 7 \mu s = 84 \mu H$$

Substituting a standard inductor value of 68 μ H with 0.2 Ω dc resistance will produce a peak switch current of:

$$I_{PEAK} = \frac{6 V}{1.0 \Omega} \left(1 - e^{-\frac{10 \Omega \cdot 7 \mu s}{68 \mu H}} \right) = 587 mA$$

Once the peak current is known, the inductor energy can be calculated from Equation 5:

$$E_L = \frac{1}{2} (68 \mu H) \cdot (587 mA)^2 = 11.7 \mu J$$

Since the inductor energy of 11.7 μ J is greater than the P_L/f_{OSC} requirement of 3.6 μ J, the 68 μ H inductor will work in this application. By substituting other inductor values into the same equations, the optimum inductor value can be selected.

When selecting an inductor, the peak current must not exceed the maximum switch current of 1.5 A. If the equations shown above result in peak currents > 1.5 A, the ADP1110 should be considered. Since this device has a 70% duty cycle, more energy is stored in the inductor on each cycle. This results in greater output power.

The peak current must be evaluated for both minimum and maximum values of input voltage. If the switch current is high when V_{IN} is at its minimum, the 1.5 A limit may be exceeded at the maximum value of V_{IN} . In this case, the ADP1111's current limit feature can be used to limit switch current. Simply select a resistor (using Figure 6) that will limit the maximum switch current to the I_{PEAK} value calculated for the minimum value of V_{IN} . This will improve efficiency by producing a constant I_{PEAK} as V_{IN} increases. See the "Limiting the Switch Current" section of this data sheet for more information.

Note that the switch current limit feature does not protect the circuit if the output is shorted to ground. In this case, current is only limited by the dc resistance of the inductor and the forward voltage of the diode.

INDUCTOR SELECTION-STEP-DOWN CONVERTER

The step-down mode of operation is shown in Figure 19.

Unlike the step-up mode, the ADP1111's power switch does not saturate when operating in the step-down mode; therefore, switch current should be limited to 650 mA in this mode. If the input voltage will vary over a wide range, the I_{LIM} pin can be used to limit the maximum switch current. Higher switch current is possible by adding an external switching transistor as shown in Figure 21.

The first step in selecting the step-down inductor is to calculate the peak switch current as follows:

$$I_{PEAK} = \frac{2 I_{OUT}}{DC} \left(\frac{V_{OUT} + V_D}{V_{IN} - V_{SW} + V_D} \right) \quad (\text{Equation 6})$$

where DC = duty cycle (0.5 for the ADP1111)

V_{SW} = voltage drop across the switch

V_D = diode drop (0.5 V for a 1N5818)

I_{OUT} = output current

V_{OUT} = the output voltage

V_{IN} = the minimum input voltage

ADP1111

As previously mentioned, the switch voltage is higher in step-down mode than in step-up mode. V_{SW} is a function of switch current and is therefore a function of V_{IN} , L , time and V_{OUT} . For most applications, a V_{SW} value of 1.5 V is recommended.

The inductor value can now be calculated:

$$L = \frac{V_{IN(MIN)} - V_{SW} - V_{OUT}}{I_{PEAK}} \cdot t_{ON} \quad (\text{Equation 7})$$

where t_{ON} = switch ON time (7 μ s).

If the input voltage will vary (such as an application that must operate from a 9 V, 12 V or 15 V source), an R_{LIM} resistor should be selected from Figure 6. The R_{LIM} resistor will keep switch current constant as the input voltage rises. Note that there are separate R_{LIM} values for step-up and step-down modes of operation.

For example, assume that +5 V at 300 mA is required from a +12 V to +24 V source. Deriving the peak current from Equation 6 yields:

$$I_{PEAK} = \frac{2 \cdot 300 \text{ mA}}{0.5} \left(\frac{5 + 0.5}{12 - 1.5 + 0.5} \right) = 600 \text{ mA}$$

Then, the peak current can be inserted into Equation 7 to calculate the inductor value:

$$L = \frac{12 - 1.5 - 5}{600 \text{ mA}} \cdot 7 \mu\text{s} = 64 \mu\text{H}$$

Since 64 μ H is not a standard value, the next lower standard value of 56 μ H would be specified.

To avoid exceeding the maximum switch current when the input voltage is at +24 V, an R_{LIM} resistor should be specified. Using the step-down curve of Figure 6, a value of 560 Ω will limit the switch current to 600 mA.

INDUCTOR SELECTION-POSITIVE-TO-NEGATIVE CONVERTER

The configuration for a positive-to-negative converter using the ADP1111 is shown in Figure 22. As with the step-up converter, all of the output power for the inverting circuit must be supplied by the inductor. The required inductor power is derived from the formula:

$$P_L = (|V_{OUT}| + V_D) \cdot (I_{OUT}) \quad (\text{Equation 8})$$

The ADP1111 power switch does not saturate in positive-to-negative mode. The voltage drop across the switch can be modeled as a 0.75 V base-emitter diode in series with a 0.65 Ω resistor. When the switch turns on, inductor current will rise at a rate determined by:

$$I_L(t) = \frac{V_L}{R'} \left(1 - e^{-\frac{R't}{L}} \right) \quad (\text{Equation 9})$$

where: $R' = 0.65 \Omega + R_{L(DC)}$

$$V_L = V_{IN} - 0.75 \text{ V}$$

For example, assume that a -5 V output at 50 mA is to be generated from a +4.5 V to +5.5 V source. The power in the inductor is calculated from Equation 8:

$$P_L = (|-5 \text{ V}| + 0.5 \text{ V}) \cdot (50 \text{ mA}) = 275 \text{ mW}$$

During each switching cycle, the inductor must supply the following energy:

$$\frac{P_L}{f_{OSC}} = \frac{275 \text{ mW}}{72 \text{ kHz}} = 3.8 \mu\text{J}$$

Using a standard inductor value of 56 μ H with 0.2 Ω dc resistance will produce a peak switch current of:

$$I_{PEAK} = \frac{4.5 \text{ V} - 0.75 \text{ V}}{0.65 \Omega + 0.2 \Omega} \left(1 - e^{-\frac{0.85 \Omega \cdot 7 \mu\text{s}}{56 \mu\text{H}}} \right) = 445 \text{ mA}$$

Once the peak current is known, the inductor energy can be calculated from (Equation 9):

$$E_L = \frac{1}{2} (56 \mu\text{H}) \cdot (445 \text{ mA})^2 = 5.54 \mu\text{J}$$

Since the inductor energy of 5.54 μ J is greater than the P_L/f_{OSC} requirement of 3.82 μ J, the 56 μ H inductor will work in this application.

The input voltage only varies between 4.5 V and 5.5 V in this application. Therefore, the peak current will not change enough to require an R_{LIM} resistor and the I_{LIM} pin can be connected directly to V_{IN} . Care should be taken, of course, to ensure that the peak current does not exceed 650 mA.

CAPACITOR SELECTION

For optimum performance, the ADP1111's output capacitor must be selected carefully. Choosing an inappropriate capacitor can result in low efficiency and/or high output ripple.

Ordinary aluminum electrolytic capacitors are inexpensive but often have poor Equivalent Series Resistance (ESR) and Equivalent Series Inductance (ESL). Low ESR aluminum capacitors, specifically designed for switch mode converter applications, are also available, and these are a better choice than general purpose devices. Even better performance can be achieved with tantalum capacitors, although their cost is higher. Very low values of ESR can be achieved by using OS-CON capacitors (Sanyo Corporation, San Diego, CA). These devices are fairly small, available with tape-and-reel packaging and have very low ESR.

The effects of capacitor selection on output ripple are demonstrated in Figures 15, 16 and 17. These figures show the output of the same ADP1111 converter that was evaluated with three different output capacitors. In each case, the peak switch current is 500 mA, and the capacitor value is 100 μ F. Figure 15 shows a Panasonic HF-series 16-volt radial cap. When the switch turns off, the output voltage jumps by about 90 mV and then decays as the inductor discharges into the capacitor. The rise in voltage indicates an ESR of about 0.18 Ω . In Figure 16, the aluminum electrolytic has been replaced by a Sprague 293D series, a 6 V tantalum device. In this case the output jumps about 30 mV, which indicates an ESR of 0.06 Ω . Figure 17 shows an OS-CON 16-volt capacitor in the same circuit, and ESR is only 0.02 Ω .

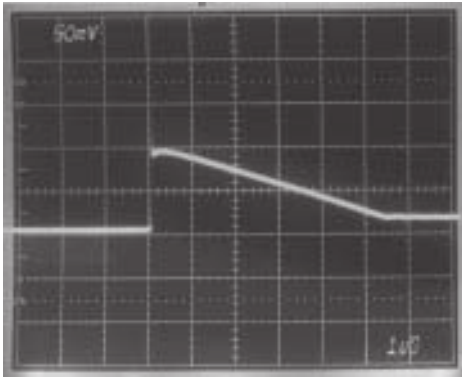

Figure 15. Aluminum Electrolytic

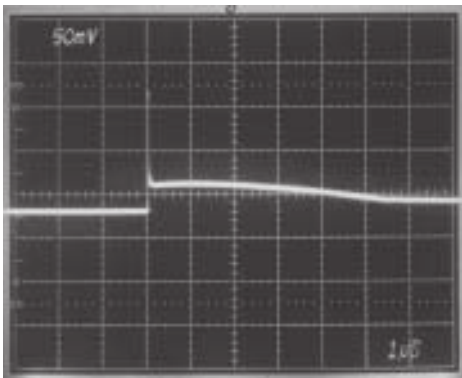

Figure 16. Tantalum Electrolytic

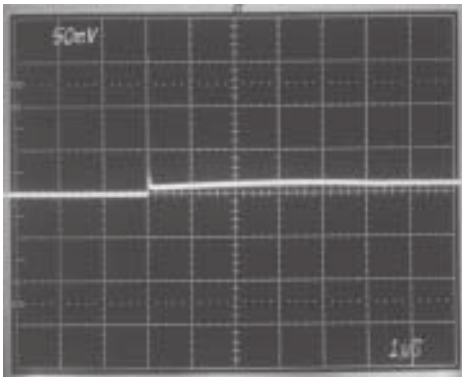

Figure 17. OS-CON Capacitor

If low output ripple is important, the user should consider the ADP3000. Because this device switches at 400 kHz, lower peak current can be used. Also, the higher switching frequency simplifies the design of the output filter. Consult the ADP3000 data sheet for additional details.

DIODE SELECTION

In specifying a diode, consideration must be given to speed, forward voltage drop and reverse leakage current. When the ADP1111 switch turns off, the diode must turn on rapidly if high efficiency is to be maintained. Schottky rectifiers, as well as fast signal diodes such as the 1N4148, are appropriate. The forward voltage of the diode represents power that is not delivered to the load, so V_F must also be minimized. Again, Schottky diodes are recommended. Leakage current is especially important in low-current applications where the leakage can be a significant percentage of the total quiescent current.

For most circuits, the 1N5818 is a suitable companion to the ADP1111. This diode has a V_F of 0.5 V at 1 A, 4 μA to 10 μA leakage, and fast turn-on and turn-off times. A surface mount version, the MBR5130T3, is also available.

For switch currents of 100 mA or less, a Schottky diode such as the BAT85 provides a V_F of 0.8 V at 100 mA and leakage less than 1 μA . A similar device, the BAT54, is available in a SOT23 package. Even lower leakage, in the 1 nA to 5 nA range, can be obtained with a 1N4148 signal diode.

General purpose rectifiers, such as the 1N4001, are not suitable for ADP1111 circuits. These devices, which have turn-on times of 10 μs or more, are far too slow for switching power supply applications. Using such a diode “just to get started” will result in wasted time and effort. Even if an ADP1111 circuit appears to function with a 1N4001, the resulting performance will not be indicative of the circuit performance when the correct diode is used.

CIRCUIT OPERATION, STEP-UP (BOOST) MODE

In boost mode, the ADP1111 produces an output voltage that is higher than the input voltage. For example, +12 V can be generated from a +5 V logic power supply or +5 V can be derived from two alkaline cells (+3 V).

Figure 18 shows an ADP1111 configured for step-up operation. The collector of the internal power switch is connected to the output side of the inductor, while the emitter is connected to GND. When the switch turns on, pin SW1 is pulled near ground. This action forces a voltage across L1 equal to $V_{IN} - V_{CE(SAT)}$, and current begins to flow through L1. This current reaches a final value (ignoring second-order effects) of:

$$I_{PEAK} \cong \frac{V_{IN} - V_{CE(SAT)}}{L} \cdot 7\mu\text{s}$$

where 7 μs is the ADP1111 switch’s “on” time.

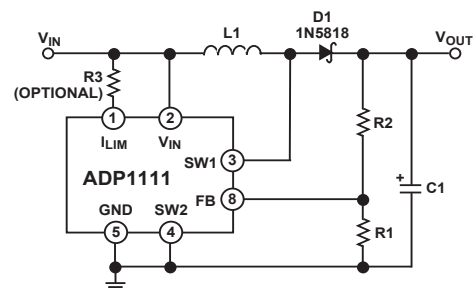

Figure 18. Step-Up Mode Operation

When the switch turns off, the magnetic field collapses. The polarity across the inductor changes, current begins to flow through D1 into the load, and the output voltage is driven above the input voltage.

The output voltage is fed back to the ADP1111 via resistors R1 and R2. When the voltage at pin FB falls below 1.25 V, SW1 turns “on” again, and the cycle repeats. The output voltage is therefore set by the formula:

$$V_{OUT} = 1.25 V \cdot \left(1 + \frac{R2}{R1} \right)$$

The circuit of Figure 18 shows a direct current path from V_{IN} to V_{OUT} , via the inductor and D1. Therefore, the boost converter is not protected if the output is short circuited to ground.

ADP1111

CIRCUIT OPERATION, STEP DOWN (BUCK) MODE

The ADP1111's step down mode is used to produce an output voltage that is lower than the input voltage. For example, the output of four NiCd cells (+4.8 V) can be converted to a +3 V logic supply.

A typical configuration for step down operation of the ADP1111 is shown in Figure 19. In this case, the collector of the internal power switch is connected to V_{IN} and the emitter drives the inductor. When the switch turns on, SW2 is pulled up towards V_{IN} . This forces a voltage across L1 equal to $V_{IN} - V_{CE} - V_{OUT}$ and causes current to flow in L1. This current reaches a final value of:

$$I_{PEAK} \cong \frac{V_{IN} - V_{CE} - V_{OUT}}{L} \cdot 7\mu s$$

where $7\mu s$ is the ADP1111 switch's "on" time.

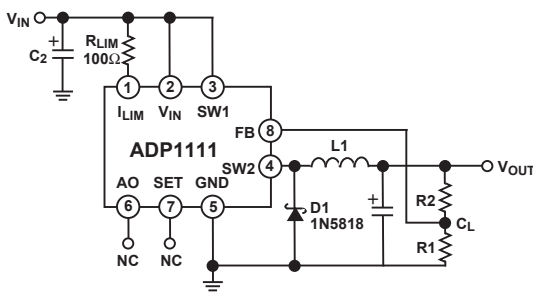

Figure 19. Step-Down Mode Operation

When the switch turns off, the magnetic field collapses. The polarity across the inductor changes, and the switch side of the inductor is driven below ground. Schottky diode D1 then turns on, and current flows into the load. Notice that the Absolute Maximum Rating for the ADP1111's SW2 pin is 0.5 V below ground. To avoid exceeding this limit, D1 must be a Schottky diode. If a silicon diode is used for D1, Pin SW2 can go to -0.8 V , which will cause potentially damaging power dissipation within the ADP1111.

The output voltage of the buck regulator is fed back to the ADP1111's FB pin by resistors R1 and R2. When the voltage at pin FB falls below 1.25 V, the internal power switch turns "on" again, and the cycle repeats. The output voltage is set by the formula:

$$V_{OUT} = 1.25\text{ V} \cdot \left(1 + \frac{R2}{R1}\right)$$

When operating the ADP1111 in step-down mode, the output voltage is impressed across the internal power switch's emitter-base junction when the switch is off. To protect the switch, the output voltage should be limited to 6.2 V or less. If a higher output voltage is required, a Schottky diode should be placed in series with SW2 as shown in Figure 20.

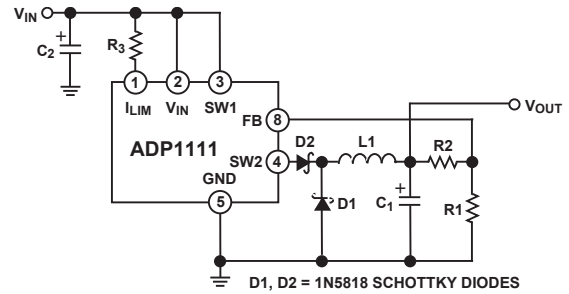

Figure 20. Step-Down Model, $V_{OUT} > 6.2\text{ V}$

If the input voltage to the ADP1111 varies over a wide range, a current limiting resistor at Pin 1 may be required. If a particular circuit requires high peak inductor current with minimum input supply voltage, the peak current may exceed the switch maximum rating and/or saturate the inductor when the supply voltage is at the maximum value. See the "Limiting the Switch Current" section of this data sheet for specific recommendations.

INCREASING OUTPUT CURRENT IN THE STEP-DOWN REGULATOR

Unlike the boost configuration, the ADP1111's internal power switch is not saturated when operating in step-down mode. A conservative value for the voltage across the switch in step-down mode is 1.5 V. This results in high power dissipation within the ADP1111 when high peak current is required. To increase the output current, an external PNP switch can be added (Figure 21). In this circuit, the ADP1111 provides base drive to Q1 through R3, while R4 ensures that Q1 turns off rapidly. Because the ADP1111's internal current limiting function will not work in this circuit, R5 is provided for this purpose. With the value shown, R5 limits current to 2 A. In addition to reducing power dissipation on the ADP1111, this circuit also reduces the switch voltage. When selecting an inductor value for the circuit of Figure 21, the switch voltage can be calculated from the formula:

$$V_{SW} = V_{R5} + V_{Q1(SAT)} \cong 0.6\text{ V} + 0.4\text{ V} \cong 1\text{ V}$$

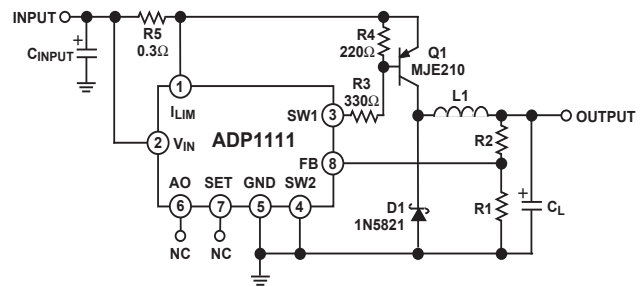

Figure 21. High Current Step-Down Operation

Table I. Component Selection for Typical Converters

Input Voltage	Output Voltage	Output Current (mA)	Circuit Figure	Inductor Value	Inductor Part No.	Capacitor Value	Notes
2 to 3.1	5	90 mA	4	15 μ H	CD75-150K	33 μ F	*
2 to 3.1	5	10 mA	4	47 μ H	CTX50-1	10 μ F	
2 to 3.1	12	30 mA	4	15 μ H	CD75-150K	22 μ F	
2 to 3.1	12	10 mA	4	47 μ H	CTX50-1	10 μ F	
5	12	90 mA	4	33 μ H	CD75-330K	22 μ F	
5	12	30 mA	4	47 μ H	CTX50-1	15 μ F	
6.5 to 11	5	50 mA	5	15 μ H		47 μ F	**
12 to 20	5	300 mA	5	56 μ H	CTX50-4	47 μ F	**
20 to 30	5	300 mA	5	120 μ H	CTX100-4	47 μ F	**
5	-5	7 mA	6	56 μ H	CTX50-4	47 μ F	
12	-5	250 mA	6	120 μ H	CTX100-4	100 μ F	**

NOTES

CD = Sumida.

CTX = Coiltronics.

*Add 47 Ω from I_{LIM} to V_{IN} .

**Add 220 Ω from I_{LIM} to V_{IN} .

POSITIVE-TO-NEGATIVE CONVERSION

The ADP1111 can convert a positive input voltage to a negative output voltage as shown in Figure 22. This circuit is essentially identical to the step-down application of Figure 19, except that the “output” side of the inductor is connected to power ground. When the ADP1111’s internal power switch turns off, current flowing in the inductor forces the output ($-V_{OUT}$) to a negative potential. The ADP1111 will continue to turn the switch on until its FB pin is 1.25 V above its GND pin, so the output voltage is determined by the formula:

$$V_{OUT} = 1.25 V \cdot \left(1 + \frac{R2}{R1} \right)$$

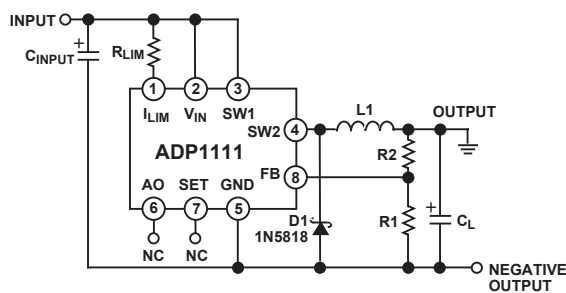

Figure 22. Positive-to-Negative Converter

The design criteria for the step-down application also apply to the positive-to-negative converter. The output voltage should be limited to $|6.2 V|$ unless a diode is inserted in series with the SW2 pin (see Figure 20.) Also, D1 must again be a Schottky diode to prevent excessive power dissipation in the ADP1111.

NEGATIVE-TO-POSITIVE CONVERSION

The circuit of Figure 23 converts a negative input voltage to a positive output voltage. Operation of this circuit configuration is similar to the step-up topology of Figure 18, except the current through feedback resistor R2 is level-shifted below ground by a PNP transistor. The voltage across R2 is $V_{OUT} - V_{BEQ1}$. However, diode D2 level-shifts the base of Q1 about 0.6 V below ground thereby cancelling the V_{BE} of Q1. The addition of D2

also reduces the circuit’s output voltage sensitivity to temperature, which otherwise would be dominated by the $-2 mV V_{BE}$ contribution of Q1. The output voltage for this circuit is determined by the formula:

$$V_{OUT} = 1.25 V \cdot \frac{R2}{R1}$$

Unlike the positive step-up converter, the negative-to-positive converter’s output voltage can be either higher or lower than the input voltage.

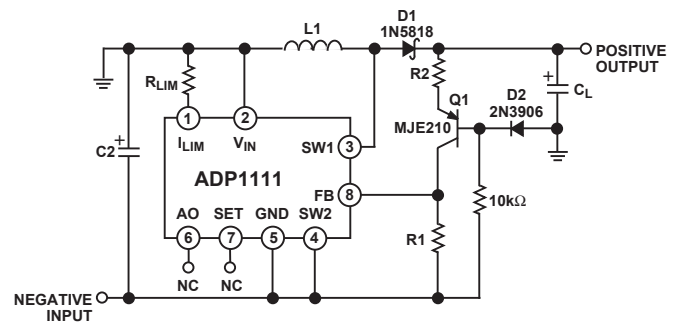

Figure 23. ADP1111 Negative-to-Positive Converter

LIMITING THE SWITCH CURRENT

The ADP1111’s R_{LIM} pin permits the switch current to be limited with a single resistor. This current limiting action occurs on a pulse by pulse basis. This feature allows the input voltage to vary over a wide range without saturating the inductor or exceeding the maximum switch rating. For example, a particular design may require peak switch current of 800 mA with a 2.0 V input. If V_{IN} rises to 4 V, however, the switch current will exceed 1.6 A. The ADP1111 limits switch current to 1.5 A and thereby protects the switch, but the output ripple will increase. Selecting the proper resistor will limit the switch current to 800 mA, even if V_{IN} increases. The relationship between R_{LIM} and maximum switch current is shown in Figure 6.

The I_{LIM} feature is also valuable for controlling inductor current when the ADP1111 goes into continuous-conduction mode.

ADP1111

This occurs in the step-up mode when the following condition is met:

$$\frac{V_{OUT} + V_{DIODE}}{V_{IN} - V_{SW}} < \frac{1}{1 - DC}$$

where DC is the ADP1111's duty cycle. When this relationship exists, the inductor current does not go all the way to zero during the time that the switch is OFF. When the switch turns on for the next cycle, the inductor current begins to ramp up from the residual level. If the switch ON time remains constant, the inductor current will increase to a high level (see Figure 24). This increases output ripple and can require a larger inductor and capacitor. By controlling switch current with the I_{LIM} resistor, output ripple current can be maintained at the design values. Figure 25 illustrates the action of the I_{LIM} circuit.

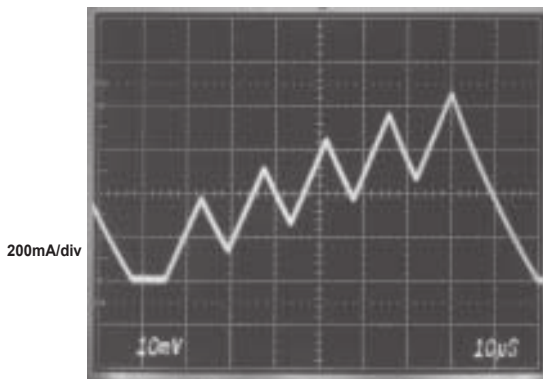

Figure 24.

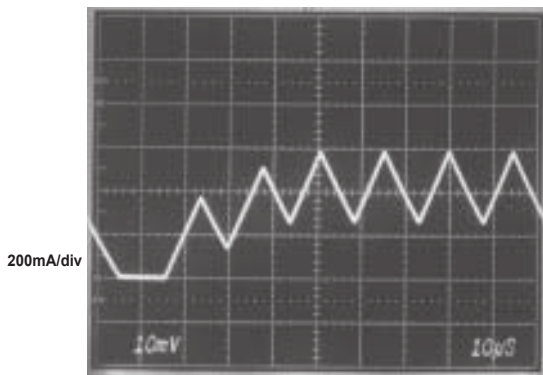

Figure 25.

The internal structure of the I_{LIM} circuit is shown in Figure 26. Q1 is the ADP1111's internal power switch that is paralleled by sense transistor Q2. The relative sizes of Q1 and Q2 are scaled so that I_{Q2} is 0.5% of I_{Q1} . Current flows to Q2 through an internal $80\ \Omega$ resistor and through the R_{LIM} resistor. These two resistors parallel the base-emitter junction of the oscillator-disable transistor, Q3. When the voltage across R1 and R_{LIM} exceeds 0.6 V, Q3 turns on and terminates the output pulse. If only the $80\ \Omega$ internal resistor is used (i.e. the I_{LIM} pin is connected directly to V_{IN}), the maximum switch current will be 1.5 A. Figure 6 gives R_{LIM} values for lower current-limit values.

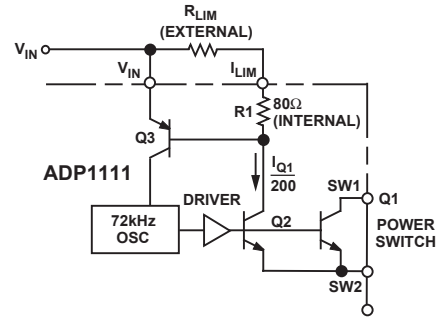

Figure 26. ADP1111 Current Limit Operation

The delay through the current limiting circuit is approximately $1\ \mu\text{s}$. If the switch ON time is reduced to less than $3\ \mu\text{s}$, accuracy of the current trip-point is reduced. Attempting to program a switch ON time of $1\ \mu\text{s}$ or less will produce spurious responses in the switch ON time; however, the ADP1111 will still provide a properly regulated output voltage.

PROGRAMMING THE GAIN BLOCK

The gain block of the ADP1111 can be used as a low-battery detector, error amplifier or linear post regulator. The gain block consists of an op amp with PNP inputs and an open-collector NPN output. The inverting input is internally connected to the ADP1111's 1.25 V reference, while the noninverting input is available at the SET pin. The NPN output transistor will sink about $300\ \mu\text{A}$.

Figure 27a shows the gain block configured as a low-battery monitor. Resistors R1 and R2 should be set to high values to reduce quiescent current, but not so high that bias current in the SET input causes large errors. A value of $33\ \text{k}\Omega$ for R2 is a good compromise. The value for R1 is then calculated from the formula:

$$R1 = \frac{V_{LOBATT} - 1.25\ \text{V}}{\frac{1.25\ \text{V}}{R2}}$$

where V_{LOBATT} is the desired low battery trip point. Since the gain block output is an open-collector NPN, a pull-up resistor should be connected to the positive logic power supply.

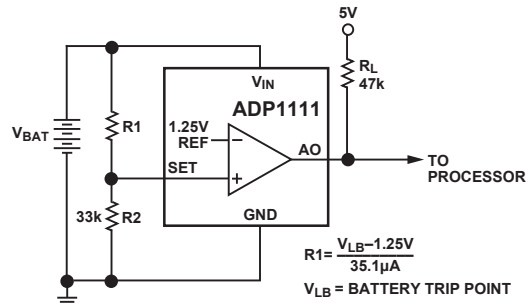

Figure 27a. Setting the Low Battery Detector Trip Point

The circuit of Figure 27b may produce multiple pulses when approaching the trip point due to noise coupled into the SET input. To prevent multiple interrupts to the digital logic, hysteresis can be added to the circuit (Figure 27). Resistor RHYS, with a value of 1 MΩ to 10 MΩ, provides the hysteresis. The addition of RHYS will change the trip point slightly, so the new value for R1 will be:

$$R1 = \frac{V_{LOBATT} - 1.25 V}{\left(\frac{1.25 V}{R2}\right) - \left(\frac{V_L - 1.25 V}{R_L + R_{HYS}}\right)}$$

where V_L is the logic power supply voltage, R_L is the pull-up resistor, and R_{HYS} creates the hysteresis.

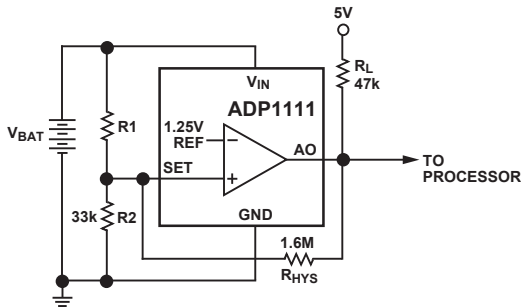

Figure 27b.

APPLICATION CIRCUITS

All Surface Mount 3 V to 5 V Step-Up Converter

This is the most basic application (along with the basic step-down configuration to follow) of the ADP1111. It takes full advantage of surface mount packaging for all the devices used in the design. The circuit can provide +5 V at 100 mA of output current and can be operated off of battery power for use in portable equipment.

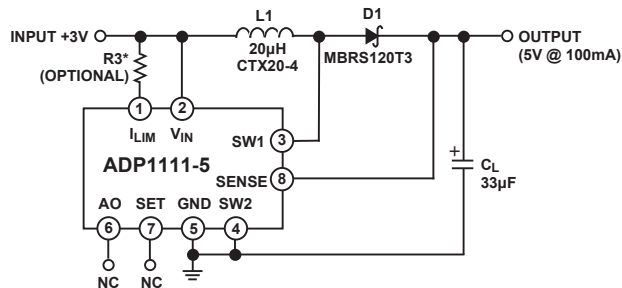

Figure 28. All Surface Mount +3 V to +5 V Step-Up Converter

9 V to 5 V Step-Down Converter

This circuit uses a 9 V battery to generate a +5 V output. The circuit will work down to 6.5 V, supplying 50 mA at this lower limit. Switch current is limited to around 500 mA by the 100 Ω resistor.

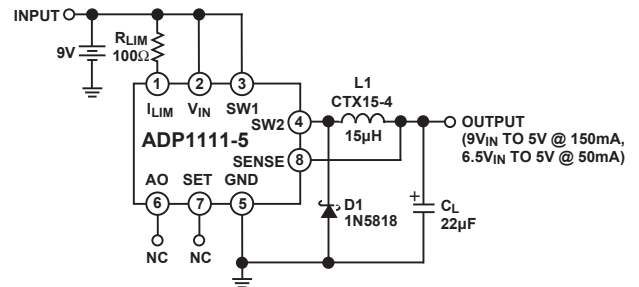

Figure 29. 9 V to 5 V Step-Down Converter

20 V to 5 V Step-Down Converter

This circuit is similar to Figure 29, except it supplies much higher output current and operates over a much wider range of input voltage. As in the previous examples, switch current is limited to 500 mA.

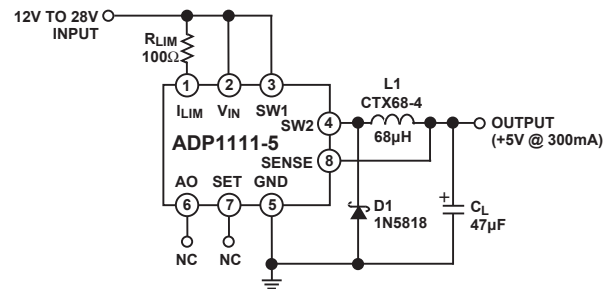

Figure 30. 20 V to 5 V Step-Down Converter

+5 V to -5 V Converter

This circuit is essentially identical to Figure 22, except it uses a fixed-output version of the ADP1111 to simplify the design somewhat.

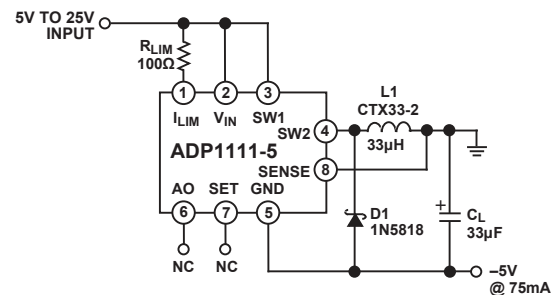

Figure 31. +5 V to -5 V Converter

ADP1111

Voltage-Controlled Positive-to-Negative Converter

By including an op amp in the feedback path, a simple positive-to-negative converter can be made to give an output that is a linear multiple of a controlling voltage, V_c . The op amp, an OP196, rail-to-rail input and output amplifier, sums the currents from the output and controlling voltage and drives the FB pin either high or low, thereby controlling the on-board oscillator. The $0.22\ \Omega$ resistor limits the short-circuit current to about 3 A and, along with the BAT54 Schottky diode, helps limit the peak switch current over varying input voltages. The external power switch features an active pull-up to speed up the turn-off time of the switch. Although an IRF9530 was used in the evaluation, almost any device that can handle at least 3 A of peak current at a VDS of at least 50 V is suitable for use in this application, provided that adequate attention is paid to power dissipation. The circuit can deliver 2 W of output power with a +6-volt input from a control voltage range of 0 V to 5 V.

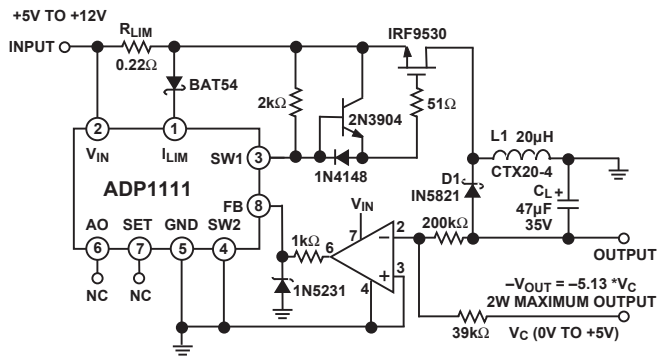

Figure 32. Voltage Controlled Positive-to-Negative Converter

+3 V to -22 V LCD Bias Generator

This circuit uses an adjustable-output version of the ADP1111 to generate a +22.5 V reference output that is level-shifted to give an output of -22 V. If operation from a +5 volt supply is desired, change R_1 to 47 ohms. The circuit will deliver 7 mA with a 3 volt supply and 40 mA with a 5 volt supply.

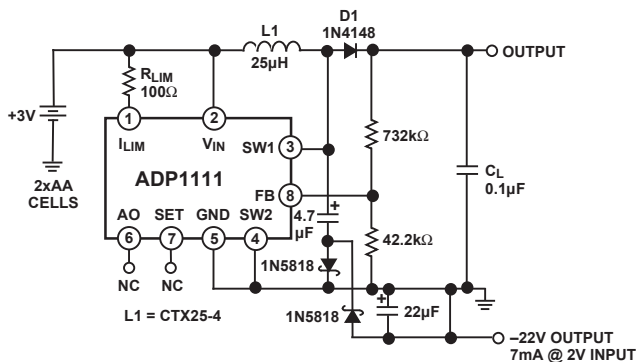

Figure 33. 3 V to -22 V LCD Bias Generator

High Power, Low Quiescent Current Step-Down Converter

By making use of the fact that the feedback pin directly controls the internal oscillator, this circuit achieves a shutdown-like state by forcing the feedback pin above the 1.25 V comparator threshold. The logic level at the 1N4148 diode anode needs to be at least 2 V for reliable standby operation.

The external switch driver circuit features an active pull-up device, a 2N3904 transistor, to ensure that the power MOSFET turns off quickly. Almost any power MOSFET will do as the switch as long as the device can withstand the 18 volt V_{GS} and is reasonably robust. The $0.22\ \Omega$ resistor limits the short-circuit current to about 3 A and, along with the BAT54 Schottky diode, helps to limit the peak switch current over varying input voltages.

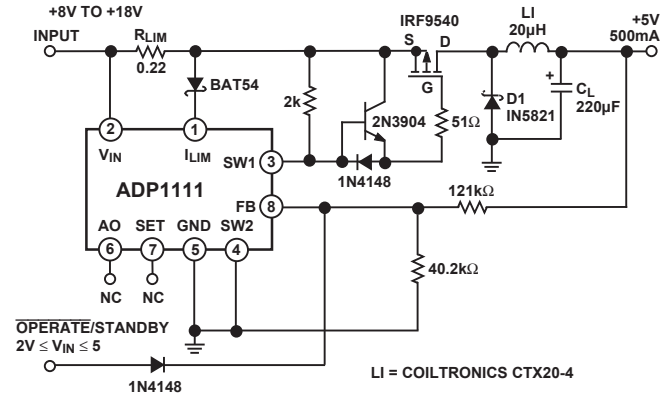
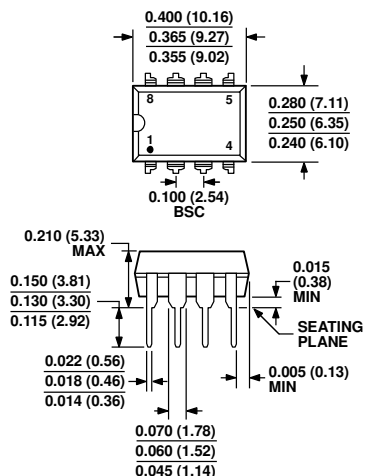

Figure 34. High Power, Low Quiescent Current Step-Down Converter

NOTES

1. All inductors referenced are Coiltronics CTX-series except where noted.
2. If the source of power is more than an inch or so from the converter, the input to the converter should be bypassed with approximately $10\ \mu\text{F}$ of capacitance. This capacitor should be a good quality tantalum or aluminum electrolytic.

OUTLINE DIMENSIONS



COMPLIANT TO JEDEC STANDARDS MS-001
 CONTROLLING DIMENSIONS ARE IN INCHES; MILLIMETER DIMENSIONS (IN PARENTHESES) ARE ROUNDED-OFF INCH EQUIVALENTS FOR REFERENCE ONLY AND ARE NOT APPROPRIATE FOR USE IN DESIGN. CORNER LEADS MAY BE CONFIGURED AS WHOLE OR HALF LEADS.

Figure 35. 8-Lead Plastic Dual In-Line Package (PDIP) Narrow Body (N-8)
 Dimensions shown in inches and (millimeters)

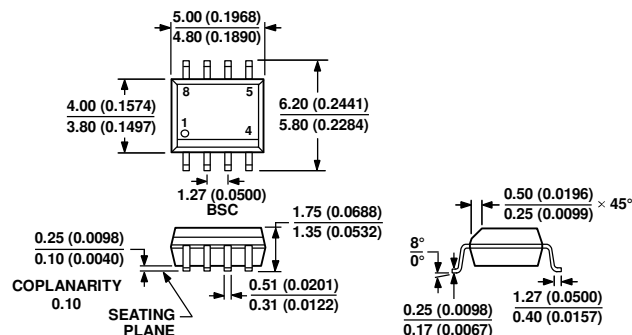
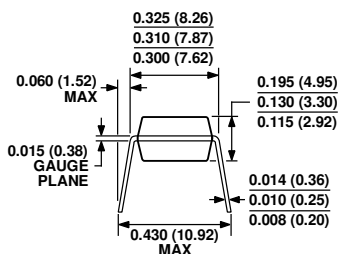

COMPLIANT TO JEDEC STANDARDS MS-012-AA
 CONTROLLING DIMENSIONS ARE IN MILLIMETERS; INCH DIMENSIONS (IN PARENTHESES) ARE ROUNDED-OFF MILLIMETER EQUIVALENTS FOR REFERENCE ONLY AND ARE NOT APPROPRIATE FOR USE IN DESIGN.

Figure 36. 8-Lead Standard Small Outline Package (SOIC_N) Narrow Body (R-8)
 Dimensions shown in millimeters and (inches)

ORDERING GUIDE

Model ¹	Output Voltage	Temperature Range	Package Description	Package Option
ADP1111ANZ-12	12 V	-40°C to +85°C	8-Lead Plastic Dual In-Line Package [PDIP]	N-8
ADP1111ANZ-3.3	3.3 V	-40°C to +85°C	8-Lead Plastic Dual In-Line Package [PDIP]	N-8
ADP1111ANZ-5	5 V	-40°C to +85°C	8-Lead Plastic Dual In-Line Package [PDIP]	N-8
ADP1111ARZ	ADJ	-40°C to +85°C	8-Lead Standard Small Outline Package [SOIC_N]	R-8
ADP1111ARZ-12	12 V	-40°C to +85°C	8-Lead Standard Small Outline Package [SOIC_N]	R-8
ADP1111ARZ-12-REEL	12 V	-40°C to +85°C	8-Lead Standard Small Outline Package [SOIC_N]	R-8
ADP1111ARZ-3.3	3.3 V	-40°C to +85°C	8-Lead Standard Small Outline Package [SOIC_N]	R-8
ADP1111ARZ-5	5 V	-40°C to +85°C	8-Lead Standard Small Outline Package [SOIC_N]	R-8
ADP1111ARZ-5-REEL	5 V	-40°C to +85°C	8-Lead Standard Small Outline Package [SOIC_N]	R-8
ADP1111ARZ-REEL	ADJ	-40°C to +85°C	8-Lead Standard Small Outline Package [SOIC_N]	R-8

¹ Z = RoHS Compliant Part.