

© - TE Connectivity. All Rights Reserved.

REVISIONS				
P	LTR	DESCRIPTION	DATE	APVD
	G5	REVISED PER ECN-22-156403	03JUN2022	RK CSD

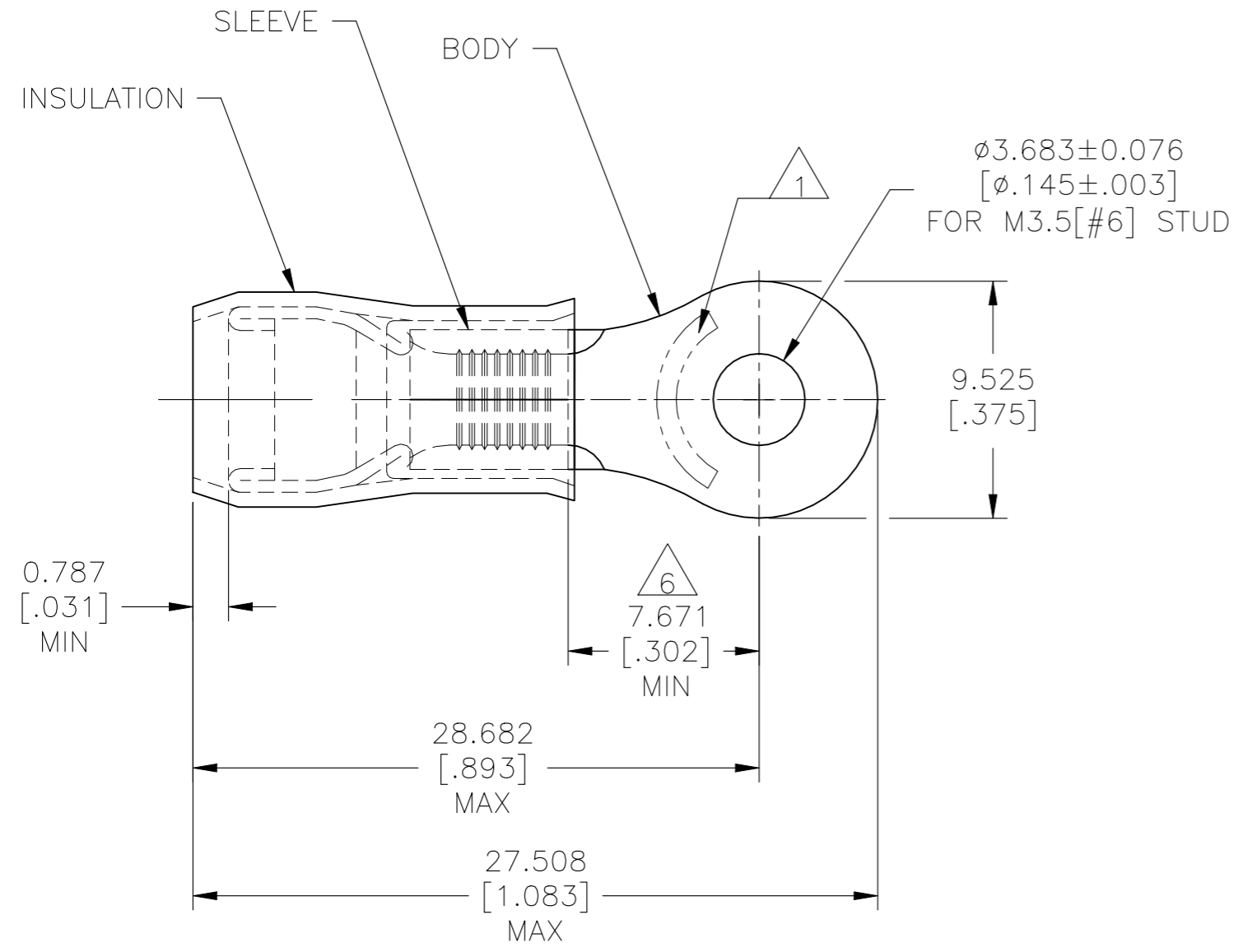

AMP WIRE RANGE	E13288 Listed	LR7189 Certified
12-10 AWG SOLID OR STRANDED	12-10 AWG SOLID OR STRANDED	12-10 AWG SOLID OR STRANDED

- 1 STAMP "AMP 12-10*" APPROX AS SHOWN
- 2 WIRE INSULATION: $\phi 3.810-5.842[\phi .150-.230]$
- 3 BODY MATERIAL THK: $1.016 \pm 0.051[.040 \pm .002]$
- 4 BODY & SLEEVE: TIN PLATE $0.00254[.000100]$ MIN EXT THK PER ASTM B545
- 5 BODY & SLEEVE- CU PER ASTM B152 INSULATION - NYLON PER ASTM D4066 COLOR - YELLOW
- 6 APPLIES FROM EDGE OF METAL WIRE BARREL TO CENTER OF STUD HOLE.
- 7 MEETS MS25036-111, CLASS 1
- 8 NOTE DELETED

2500	ON TAPE & REEL	2-320567-2
500	LOOSE PIECE	320567
QTY	PACKAGE TYPE	PART NO

CUSTOMER SERVICE SYSTEMS		MAX RECOMMENDED OPERATING TEMPERATURE: 105°C[221°F] MAX	THIS DRAWING IS A CONTROLLED DOCUMENT.		DWN JR RUTH 16DEC09	TE Connectivity				
FOR ADDITIONAL PRODUCT INFORMATION OR COPIES OF DRAWINGS AND TECHNICAL DOCUMENTS	PRODUCT INFORMATION CENTER 1-800-522-6752	VOLTAGE RATING: 300 VOLT MAX	DIMENSIONS: mm [INCHES]	TOLERANCES UNLESS OTHERWISE SPECIFIED:	CHK T MICHELUTTI 16DEC09					NAME TERMINAL, RING TONGUE, PIDG WIRE SIZE: 12-10 AWG
FOR APPLICATION TOOLING INFORMATION	TOOLING ASSISTANCE CENTER 1-800-722-1111	CIRCULAR MIL AREA: 2.62-6.64mm ² [5,180-13,100] STRANDED OR SOLID		0 PLC ± - 1 PLC ± - 2 PLC ± - 3 PLC ± 0.127[.005] 4 PLC ± - ± - ANGLES ± -	APVD T MICHELUTTI 16DEC09	PRODUCT SPEC UL 486 A-B	SIZE A3	CAGE CODE 00779	DRAWING NO C-320567	RESTRICTED TO -
FOR ORDER ENTRY	1-800-526-5142	THIS DRAWING IS A CONTROLLED DOCUMENT FOR AMP INCORPORATED. IT IS SUBJECT TO CHANGE AND THE CONTROLLING ENGINEERING ORGANIZATION SHOULD BE CONTACTED FOR THE LATEST REVISION.	MATERIAL 	FINISH 	WEIGHT -	CUSTOMER DRAWING		SCALE 4:1	SHEET 1 OF 1	REV G5