

## SWITCHED CAPACITOR DC-DC CONVERTER

### DEVICE DESCRIPTION

The ZXCP330 is the first in a series of switched capacitor DC to DC converters, converting an input voltage from between 2 volts and 4.4 volts to a regulated output voltage of 3.3V with a maximum load current of 40mA. The device operates with one flying capacitor and two small bypass capacitors at input and output making for a very small solution. Very low quiescent current makes these devices ideal for low power and battery powered applications.



Regulation is achieved by sensing the output and enabling the device charge pump when it falls below the sense threshold. This technique leads to high efficiency conversion. The method is also efficient for low current loads. Here the duty cycle will be low and the quiescent current drawn whilst the charge pump is disabled is very small.

The device includes a pin for logic controlled shutdown of the output, and also features thermal shutdown, which protects against short circuit damage as well as excessive temperatures. The device is supplied in a 6 lead SOT-23 package.

Contact Zetex marketing for availability of other voltage options.

### FEATURES

- Very low power:  $I_Q = 20\mu A$
- Regulated output voltage: 3.3V,  $\pm 4\%$
- Output current: 20mA at  $V_{IN} = 2V$
- Output current: 40mA at  $V_{IN} = 2.5V$
- No inductors required
- Very low shutdown current:  $<1\mu A$
- Short circuit and over-temp protected
- Very small package: SOT23-6 pin

### APPLICATIONS

- Battery backup supplies
- Smart card readers
- Li-Ion battery backup supplies
- SIM interface supplies for cellular phones
- Hand held computers

### APPLICATIONS DIAGRAM

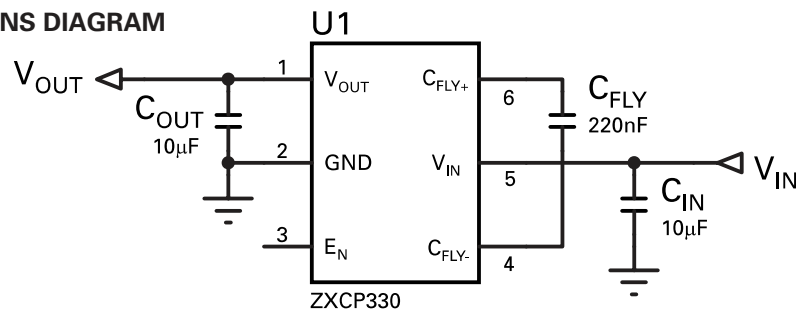

# ZXCP330

## ABSOLUTE MAXIMUM RATINGS

$V_{IN}$ to $G_{ND}$	-0.3V to +7V	Operating Temperature	-40°C to 85°C
$E_N$ to ground	-0.3V to +7V	Storage Temperature Range	-55°C to 125°C
$V_{OUT}$ to ground	-0.3V to +5.5V	Continuous Power Dissipation	Thermally ltd
$I_{OUT}$	150mA		

## ELECTRICAL CHARACTERISTICS

**TEST CONDITIONS (unless otherwise stated):**  $T_A = -40^\circ\text{C}$  to  $85^\circ\text{C}$ , (typical values at  $25^\circ\text{C}$ ),  $E_N = V_{IN}$ ,  $C_{FLY} = 0.22\mu\text{F}$ ,  $C_{IN} = 10\mu\text{F}$ ,  $C_{OUT} = 10\mu\text{F}$

PARAMETER	SYMBOL	CONDITIONS	MIN	TYP	MAX	UNIT
Input Voltage	$V_{IN}$		2.0		4.4	V
Output Voltage	$V_{OUT}$	$2V \leq V_{IN} \leq 4.4V$ , $I_{OUT} \leq 20\text{mA}$	3.17	3.3	3.43	V
Note 1		$2.5V \leq V_{IN} \leq 4.4V$ , $I_{OUT} \leq 40\text{mA}$	3.17	3.3	3.43	
Maximum Output Current	$I_{O(max)}$	$V_{IN} \geq 2V$ $V_{IN} \geq 2.5V$	20 40			mA
Output Short-Circuit Current	$I_{SC}$	$V_{IN} = 2V$		125		mA
Supply Current	$I_Q$	$2V \leq V_{IN} \leq 4.4V$ , No load		20	40	$\mu\text{A}$
Efficiency	$\eta$	$V_{IN} = 2V$ , $I_{OUT} = 20\text{mA}$		82		%
Switching Frequency	$f_{OSC}$	Oscillator free running		500		kHz
Line Regulation (Note 2)	$\Delta V_{LDR}$	$V_{IN} = 2.5V$ to $4.4V$ , $I_{OUT} = 40\text{mA}$ , $T_A = 25^\circ\text{C}$	-50	0	50	mV
Load Regulation (Note 2)	$\Delta V_{LDR}$	$I_{OUT} = 1\text{mA}$ to $40\text{mA}$ , $V_{IN} = 2.5V$ , $T_A = 25^\circ\text{C}$	-50	0	50	mV
Output Voltage Ripple	$V_R$	$f = 500\text{kHz}$ , $V_{IN} = 2.5V$ , $I_{OUT} = 40\text{mA}$		20		mV pk-pk
Enable pin Input Threshold High	$V_{EN(ON)}$	Device active	1.5		5.5	V
Enable pin Input Threshold Low	$V_{EN(OFF)}$	Device shutdown	0		0.3	V
Enable pin Input current	$I_{EN}$	$T_A = 25^\circ\text{C}$ , $E_N = 4.4V$			100	nA
Shutdown supply Current	$I_{Q(SD)}$	$E_N = 0V$ , $2V \leq V_{IN} \leq 4.4V$ , $T_A = 25^\circ\text{C}$			1	$\mu\text{A}$
Shutdown time (Note 3)	$T_{SD}$	$V_{IN} = 2.5V$ , $E_N$ changes from $1.5V$ to $0.3V$		20		$\mu\text{s}$
$V_{OUT}$ Turn-on Time	$T_{ON}$	$V_{IN} = 2V$ , $I_{OUT} = 0\text{mA}$		500		$\mu\text{s}$
Thermal Shutdown Temperature	$T_{SD}$		135	150	165	$^\circ\text{C}$

Note 1: Contact Zetex marketing for availability of alternative output voltages

Note 2: Output can deviate EITHER side of  $V_{nominal}$  for increased load current or line voltage

Note 3: Shutdown time is the time taken for  $I_{IN}$  to reduce to  $< 1\mu\text{A}$



ISSUE 1 - JANUARY 2003

## TYPICAL CHARACTERISTICS

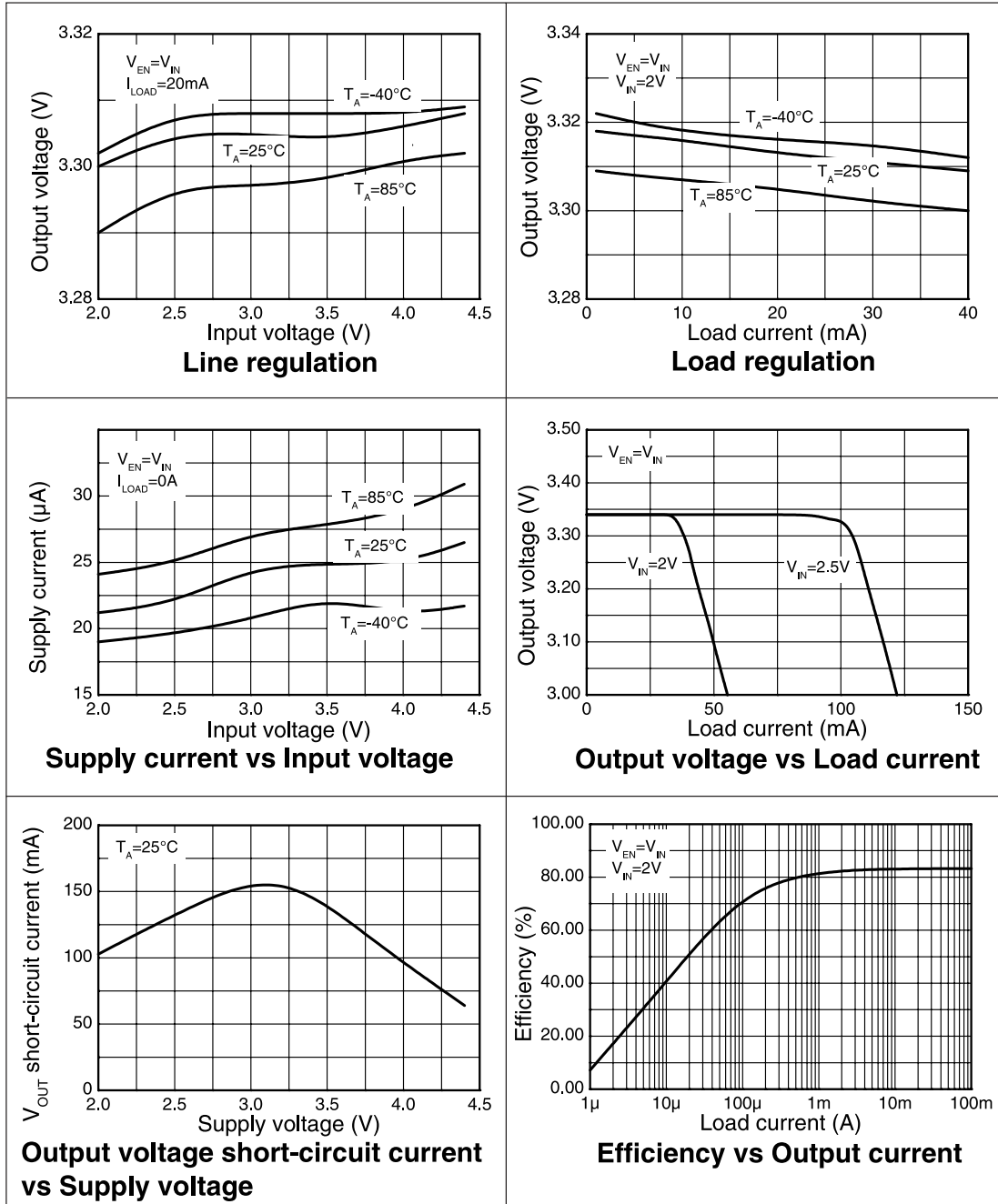

# ZXCP330

## Load transient response

Channel 1:  $V_{OUT}$  @20mV/DIV

Channel 3:  $I_{OUT}$  @10mA/DIV

$V_{IN}=4.4V$ ;  $I_{OUT}=0mA$  to 25mA; Time base=200 $\mu$ s/DIV

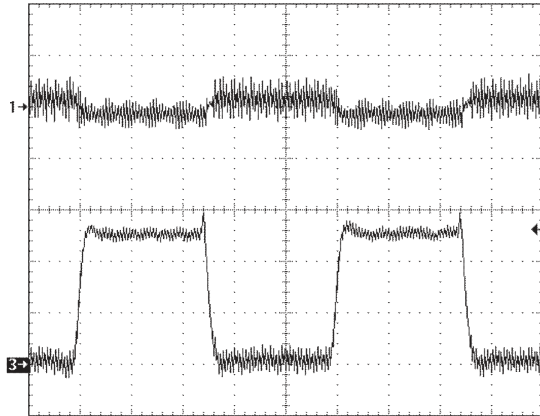

## Start-up time

Channel 1:  $V_{OUT}$  @1V/DIV

Channel 2:  $E_N$  @2V/DIV

$V_{IN}=4.4V$ ;  $I_{OUT}=40mA$ ; Time base=50 $\mu$ s/DIV

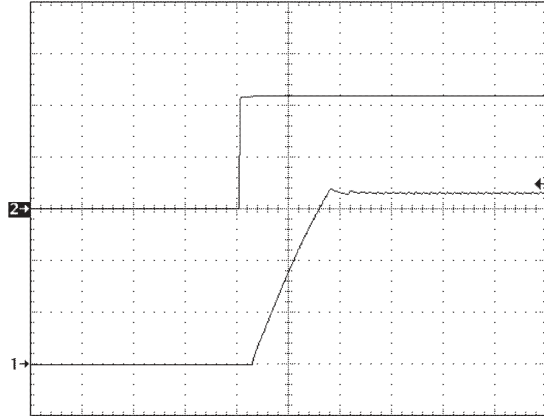

## Output ripple

Channel 1:  $V_{OUT}$  @20mV/DIV

$V_{IN}=2.5V$ ;  $I_{OUT}=40mA$ ; Time base=2 $\mu$ s/DIV

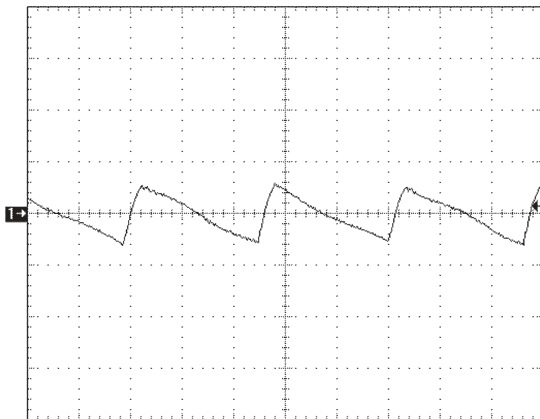

# ZXCP330

## Block Diagram

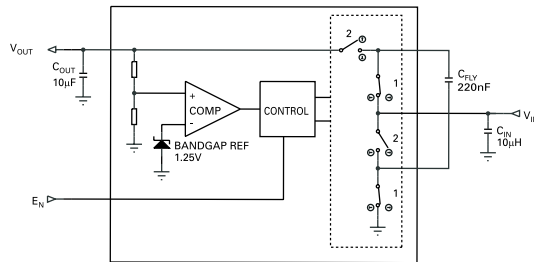

## Operational description

The ZXCP330 uses a standard switched capacitor voltage doubler topology to generate a regulated output of 3.3V from an input voltage of between 2V and 4.4V. A 500kHz internal clock generates two phases. During  $\phi_1$  (Phi One) the flying capacitor is connected between  $V_{IN}$  and ground for 1 $\mu$ s. During  $\phi_2$  the bottom plate is connected to  $V_{IN}$  and the top plate connected to  $V_{OUT}$ . A proportion of the output voltage is compared with a silicon band gap to maintain regulation. This is achieved by disabling the switching operation when the output voltage is above 3.3V and re-enabling when the output voltage falls below 3.3V. When the input voltage is near the higher limit, a large amount of charge is acquired by the flying capacitor during  $\phi_1$ , which would result in excessive output ripple. For this reason, the  $\phi_2$  phase is cut short if the voltage exceeds 3.3V, so that the full charge on the flying capacitor is not delivered to the output capacitor, hence ripple is reduced.

When the charge pump is disabled, the current drawn by the switches themselves is <1 $\mu$ A. This means that at zero loads, the load on the output will only consist of the divider driving the output comparator and the band gap circuit, resulting in the device cycling very slowly and drawing only 20 $\mu$ A.

When the circuit is either waiting for the next cycle or when it is shutdown by taking the ENABLE pin low, it remains in the  $\phi_1$  state so that the flying capacitor stays charged to the input voltage ready for  $\phi_2$  to be enabled immediately. During shutdown all analogue circuits are switched off, resulting in a current drain of <100nA.

## Power efficiency

The ZXCP330 is essentially a regulated voltage doubling charge pump. As for all voltage doubling charge pumps the input current is always twice the output current. The efficiency equation for an ideal voltage doubler is given below:

$$\eta = \frac{P_{OUT}}{P_{IN}} = \frac{V_{OUT} \times I_{OUT}}{2I_{OUT} \times V_{IN}} = \frac{V_{OUT}}{2V_{IN}}$$

The ZXCP330 maintains good efficiency at light loads because of its inherently low power design. At higher loads switching losses are minimal so efficiency is close to the ideal. See Efficiency vs Output current graph in the typical characteristics section.

## Short circuit/thermal protection

When the output of the ZXCP330 is short circuited, the resultant current depends on 2 factors. At low input voltages, the internal resistance of the switches limits the current and so it will increase with input voltage. However since, under this condition, all the input power is dissipated in the chip, it will self-heat. When the input voltage reaches around 3.2V, the value depending on the thermal mounting of the device, the chip temperature reaches a nominal value of 150°C and a thermal shutdown circuit inhibits the switching. The device will then cool and the thermal shutdown will re-enable the switching. It will cycle in and out of operation indefinitely until the short circuit is removed. Since the thermal shutdown circuit is then maintaining constant die temperature, it becomes a "constant power sink", so an increase in the input voltage results in the on time becoming proportionately less so the current decreases to maintain constant power.

## Capacitor selection

Output capacitors are a critical choice in the overall performance of the solution. Output voltage ripple, converter output power and turn-on time are influenced by the choice of capacitor. To reduce noise and output voltage ripple multi layer ceramic capacitors are recommended for use at the ZXCP330 input and output because of their inherently low ESR, typically <0.1 $\Omega$ .

The ZXCP330 will function satisfactorily over a wide range of capacitor values and load currents. However, to achieve maximum output current and minimum output ripple it is important to choose the values carefully. Available output current increases with the value of the flying capacitor, with input voltage and with clock frequency (which is fixed internally). Ripple increases with input voltage and the ratio of the flying capacitor to the output capacitor.

# ZXCP330

## Capacitor selection

An absolute minimum value of 220nF for the flying capacitor is needed to obtain maximum output current and 330nF is probably safer with tolerance in mind. However much lower capacitors can be used if the device is being used at light loads. An output capacitor of 10 $\mu$ F is recommended and this should be as low an ESR as possible as the output consists of large current spikes, so ceramics are preferred. Because the flying capacitor charges from the input via a switch, inrush current is also large and a low ESR capacitor should be used for input decoupling.

The device senses the output voltage in order to regulate at 3.3V and any inductance in series with either end of the output capacitor will cause ringing which will not be damped as the output capacitor has low ESR. This is very undesirable from a regulation or ripple aspect, therefore short connections must be used between device pins and all capacitors (see Layout Considerations later) to keep the waveforms as clean as possible.

The dielectric of the ceramic capacitor is an important consideration for the ZXCP330 operation over temperature. Zetex recommends minimum dielectric specification of X7R for the flying capacitor and X5R for the input and output capacitors. Capacitors used with a lower specification dielectric can cause excessive noise and output voltage ripple and can also compromise output current over temperature. For example a ceramic capacitor with an X7R dielectric will lose 20% of its capacitance over a -40°C to 85°C temperature range, whereas a capacitor with a Y5V dielectric loses 80% of its capacitance at -40°C and 75% at 85°C.

## Layout considerations

Careful layout of the ZXCP330 application circuit is essential for correct operation because of its high switching frequency and transient currents. For optimum converter performance use a ground plane and keep PCB tracks to all capacitors short to minimise output voltage ripple and maintain regulation under all conditions.

The recommended layout configuration is shown below:

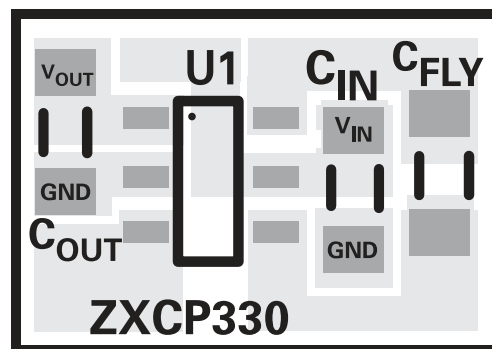

Image enlarged to show detail.



Actual size (8mmx5.3mm)

## Thermal management

At high input voltages and load currents the ZXCP330 power dissipation is high. As mentioned previously, the ZXCP330 will shutdown when the junction temperature of the device reaches 150°C. To reduce the junction temperature of the device a good thermal connection to the PCB is necessary. This can be achieved by connecting the GND pin of the ZXCP330 to a solid ground plane running on the second layer of a 2 layer PCB, adding extra heatsinking.

# ZXCP330

## TYPICAL APPLICATIONS

### Low quiescent current, regulated operation

By pulsing the enable pin (pin 3) lower quiescent operating current can be achieved while maintaining output voltage regulation. A pulse frequency of 100Hz with a 2% duty cycle is a suitable to achieve a 10 $\mu$ A operating current.

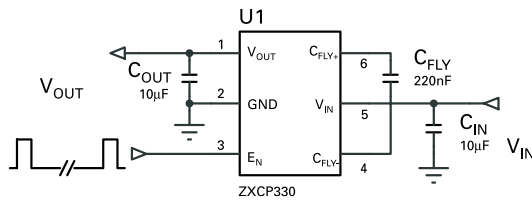

### Low noise 3V supply

By adding the ZXCL300 3V regulator to the output of the ZXCP330, the output voltage ripple can be eliminated.

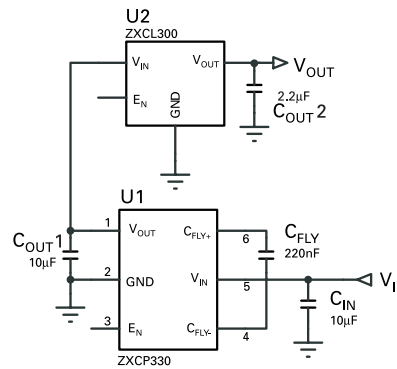

### LED driver

Below is a typical LED driving application for a cell phone. The ZXCP330 drives a coloured LED with a typical forward voltage of 2.5V from a single Li-on battery input. The LEDs can be driven in parallel to provide backlighting for LCD displays and keypad illumination. The LED current is regulated by R1 and is configured for 20mA.

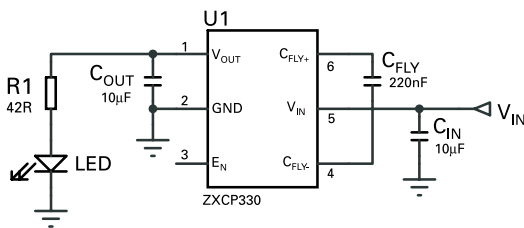

A typical waveform of the reduction in noise is shown below.

Channel 1: V<sub>OUT</sub> ZXCP330 @20mV/DIV  
 Channel 2: V<sub>OUT</sub> ZXCL300 @20mV/DIV  
 V<sub>IN</sub>=4.4V; I<sub>OUT</sub>=40mA; Time base=2 $\mu$ s/DIV

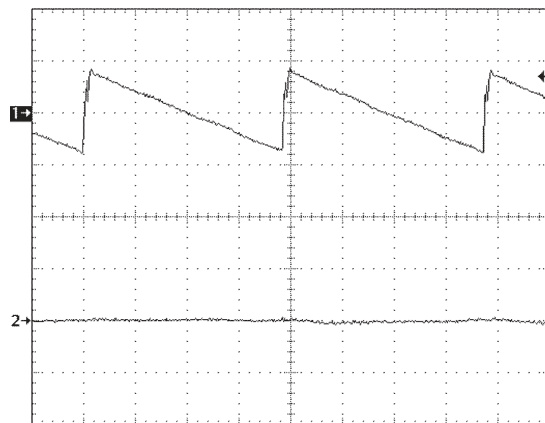

# ZXCP330

## PINOUT DIAGRAM

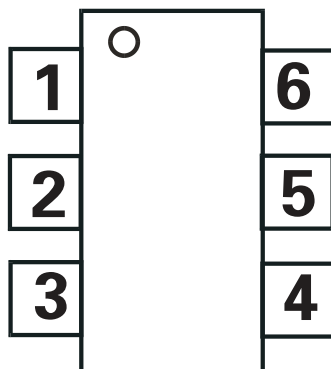

Top View

## PINOUT TABLE

Device Pin	Pin description	Pin description
1	Output voltage	$V_{OUT}$
2	Ground	GND
3	Enable	$E_N$
4	Flying capacitor negative pin	$C_{FLY-}$
5	Input voltage	$V_{IN}$
6	Flying capacitor positive pin	$C_{FLY+}$

## ORDERING INFORMATION

Device	Output voltage (V)	Part marking
ZXCP330E6	3.3	P330



# ZXCP330

## PACKAGE DIMENSIONS

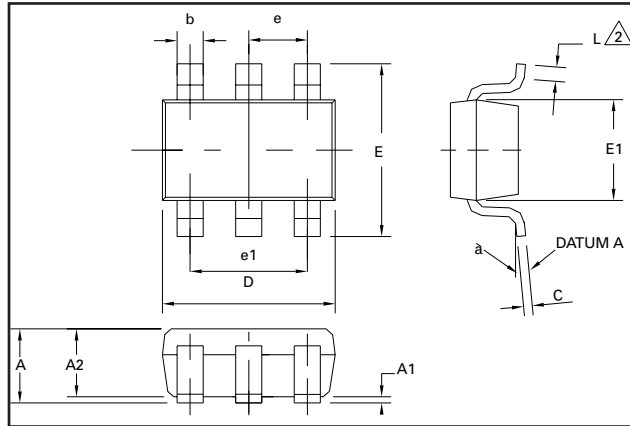

## PAD LAYOUT DETAILS

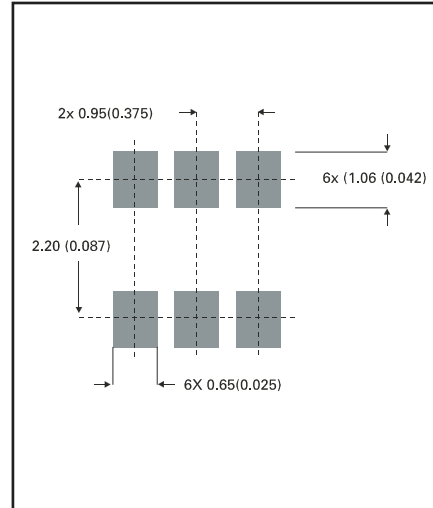

## PACKAGE DIMENSIONS

DIM	Millimetres		Inches	
	Min	Max	Min	Max
A	0.90	1.45	0.35	0.057
A1	0.00	0.15	0	0.006
A2	0.90	1.30	0.035	0.051
b	0.35	0.50	0.014	0.019
C	0.09	0.20	0.0035	0.008
D	2.80	3.00	0.110	0.118
E	2.60	3.00	0.102	0.118
E1	1.50	1.75	0.059	0.069
L	0.10	0.60	0.004	0.002
e	0.95 REF		0.037 REF	
e1	1.90 REF		0.074 REF	
L	0°	10°	0°	10°

© Zetex plc 2001

Zetex plc  
Fields New Road  
Chadderton  
Oldham, OL9 8NP  
United Kingdom  
Telephone (44) 161 622 4422  
Fax: (44) 161 622 4420

Zetex GmbH  
Streitfeldstraße 19  
D-81673 München  
Germany  
Telefon: (49) 89 45 49 49 0  
Fax: (49) 89 45 49 49 49

Zetex Inc  
700 Veterans Memorial Hwy  
Hauppauge, NY11788  
USA  
Telephone: (631) 360 2222  
Fax: (631) 360 8222

Zetex (Asia) Ltd  
3701-04 Metroplaza, Tower 1  
Hing Fong Road  
Kwai Fong  
Hong Kong  
Telephone: (852) 26100 611  
Fax: (852) 24250 494

These offices are supported by agents and distributors in major countries world-wide.

This publication is issued to provide outline information only which (unless agreed by the Company in writing) may not be used, applied or reproduced for any purpose or form part of any order or contract or be regarded as a representation relating to the products or services concerned. The Company reserves the right to alter without notice the specification, design, price or conditions of supply of any product or service.

For the latest product information, log on to [www.zetex.com](http://www.zetex.com)

ISSUE 1 - JANUARY 2003

ZETEX