

CICERONE

**MKR Main Board
LoRaWAN + GPS**

Move S.r.l.
Piazza Cavour 7 - Milano 20121

www.move-x.it
info@move-x.it

Description	2
Move-X MAMWLE	2
u-blox MAX-M10S	3
Cloud-based positioning meets LoRaWAN	4
Specs	5
Pinout: General	6
Pinout: Analog/Digital (Arduino-like)	7
Pinout: SPI, UART, I2C	8
Pinout: Timers	9
Pinout: Others	10
Mechanical dimensions	11
External resources	11
Document revision	11

Description

The **Cicerone** board is built around the **Move-X MAMWLE** module, a powerful radio module that provides both LoRaWAN connectivity and processing power for the user application.

The board is compliant with Arduino MKR form factor and embeds the best in class **u-blox MAX-M10S** GNSS module. It can be operated through a single-cell LiPo battery and embeds a charging circuit, to provide up to 10 years of battery life.

Thanks to the embedded technologies Cicerone is the perfect platform for developing IoT projects for:

- asset tracking;
- supply chain and logistics management;
- smart agriculture;
- smart cities;
- environment monitoring;
- infrastructure monitoring.

Firmware development can be done by using Arduino IDE for easier and fast prototyping or by using more advanced tools such as STM32Cube toolchain. Application notes and examples can be found here: <https://www.move-x.it/cicerone-board/>.



Move-X MAMWLE

The Move-X MAMWLE is a low-power, LoRaWAN-compliant radio module based on ST's STM32WLExx microcontroller by STMicroelectronics. Powered by a powerful 32-bit ARM Cortex-M4 with clock frequency up to 48MHz and paired with up to 64kB SRAM and 256kB Flash, it is suitable for most IoT applications.

More info and resources can be found here:

<https://www.move-x.it/mamwle-module/>

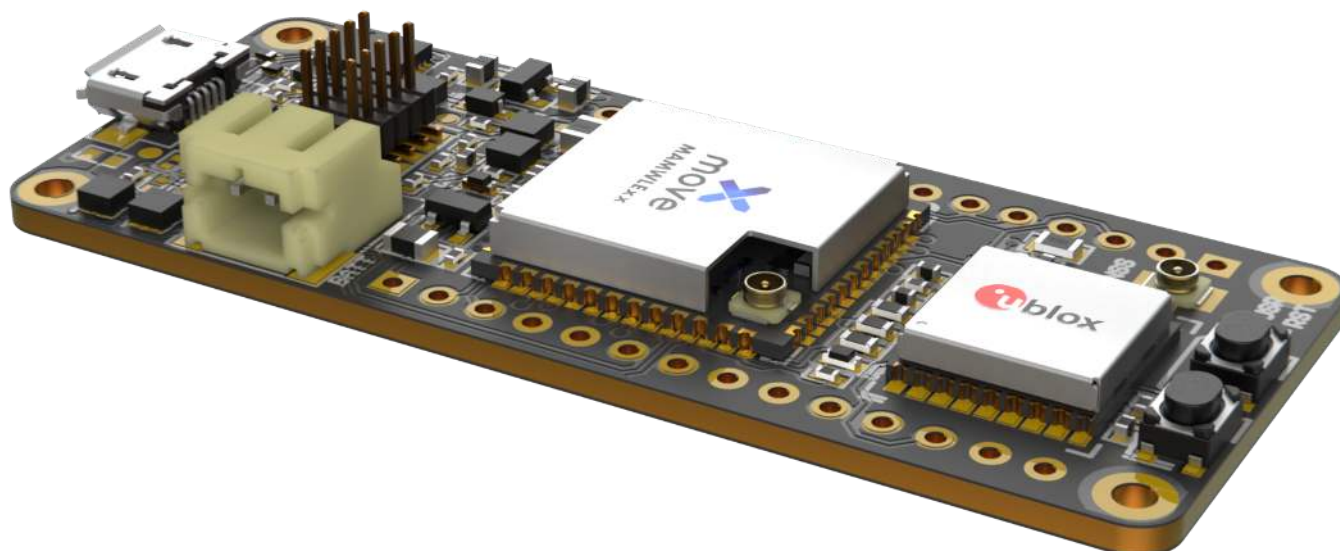

u-blox MAX-M10S

The MAX-M10S supports concurrent reception of four GNSS (**GPS**, **GLONASS**, **Galileo**, and **BeiDou**). The extremely low-power consumption of less than 25 mW in continuous tracking mode allows great power autonomy for all battery-operated devices without compromising the GNSS performance.



The MAX-M10S module integrates an LNA followed by a SAW filter in the RF path for maximum sensitivity in passive antenna designs.

u-blox Super-S technology offers great RF sensitivity and can improve the dynamic position accuracy by up to 25% with small antennas or in a non-line-of-sight scenario.

MAX-M10 detects jamming and spoofing attempts and reports them to the host, while advanced filtering algorithms mitigate the impact of RF interference and jamming.

More info and resources are available here:

<https://www.u-blox.com/en/product/max-m10-series>.

Cloud-based positioning meets LoRaWAN

Cloud-based positioning works by transmitting GNSS signals that have been pre-processed by the GNSS receiver to the cloud service using wireless communication. By reducing the time that the GNSS receiver is switched on and by outsourcing the power-intensive position calculation to the cloud, the overall power consumption of the positioning solution can be drastically reduced.

CloudLocate is the cloud-based positioning service by **u-blox**, designed to extend the battery life of power-constrained IoT devices. CloudLocate is tailored to the needs of IoT asset tracking applications that require roughly 10-meter position accuracy, few daily position updates, and only need the positioning information on the cloud, not on the device.

CloudLocate only uses an uplink to the cloud to resolve position. Because the GNSS signals are preprocessed on the receiver, the solution works with a data packet size of 12-50 bytes. This technology is a perfect match for the **Cicerone** board thanks to the **Move-X's MAMWLE LoRaWAN** module.

More info and resources are available here:

<https://www.u-blox.com/en/product/max-m10-series>

Specs

Radio module	Move-X MAMWLE (STM32WLE5)
CPU architecture	STM32 Cortex® M4 32 bit @ 48MHz
CPU flash memory	128 KB
SRAM	48 KB
LoRa radio	Semtech SX1261/2 (868-915 MHz)
GNSS module	u-blox MAX-M10S <ul style="list-style-type: none"> - BeiDou, Galileo, GLONASS, GPS / QZSS - u-blox services: CloudLocate and AssistNow
Board supply options (by priority)	<ul style="list-style-type: none"> - VIN (5V) - USB (5V) - Battery
Supported batteries	Rechargeable 3.70V Li-Ion or Li-Po with onboard SC OD OC protections, minimum suggested capacity 500mAh.
Battery management specs	210 mA, charge voltage 4.2V, red LED for status Battery voltage monitor through MAMWLE ADC
Operating voltage	3.3V
LEDs	Battery charge state (red), user application (green)
Buttons	Reset, user application
Connectors	<p>Arduino MKR headers :</p> <ul style="list-style-type: none"> - up to 22 GPIO, 16 PWM, 7 analog in - VREF output - SPI, UART, I2C <p>10-pin JTAG/SWD for ST-LINK JST PH 2.0 for Li-Po battery u.fl for LoRa antenna u.fl for GNSS passive antenna Micro USB type B</p> <ul style="list-style-type: none"> - board supply and battery charging - UART - firmware upload
USB-UART Bridge chip	CP2102N Connected to MAMWLE USART2, BOOT0 and RESET
Dimensions	62.9 x 25.0 x 7.52 mm

Pinout: General

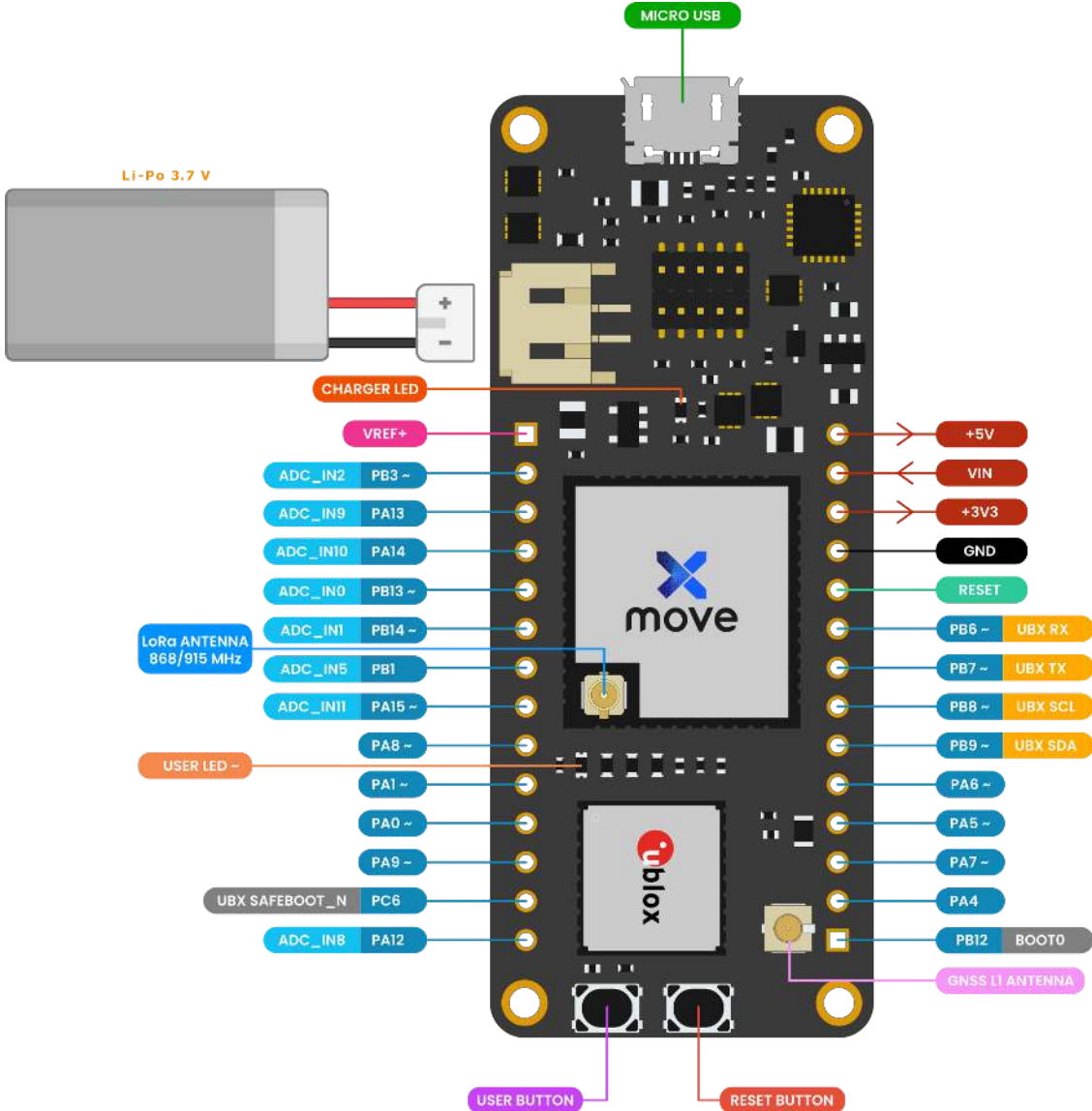

Pinout: Analog/Digital (Arduino-like)

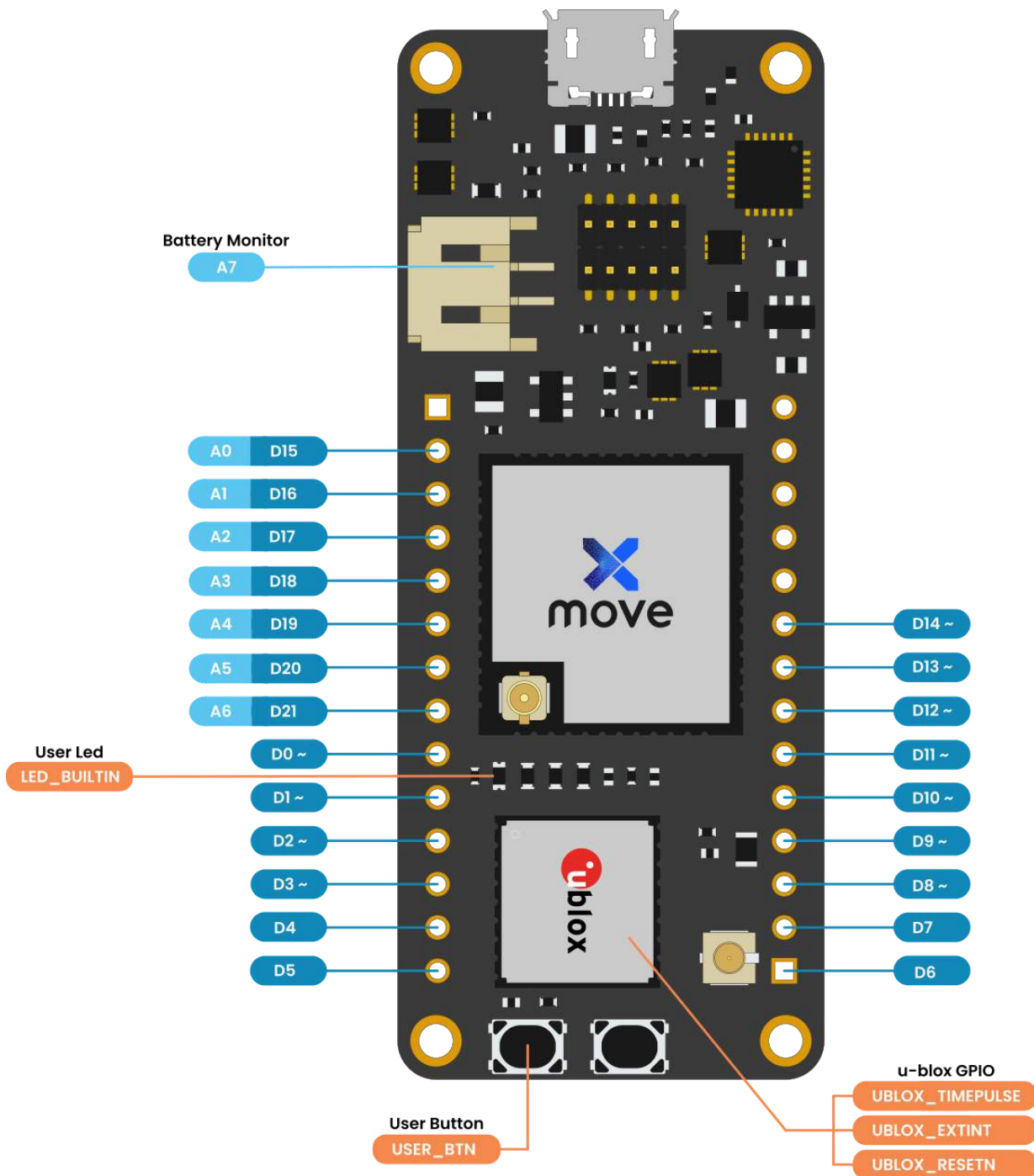

Pinout: SPI, UART, I2C

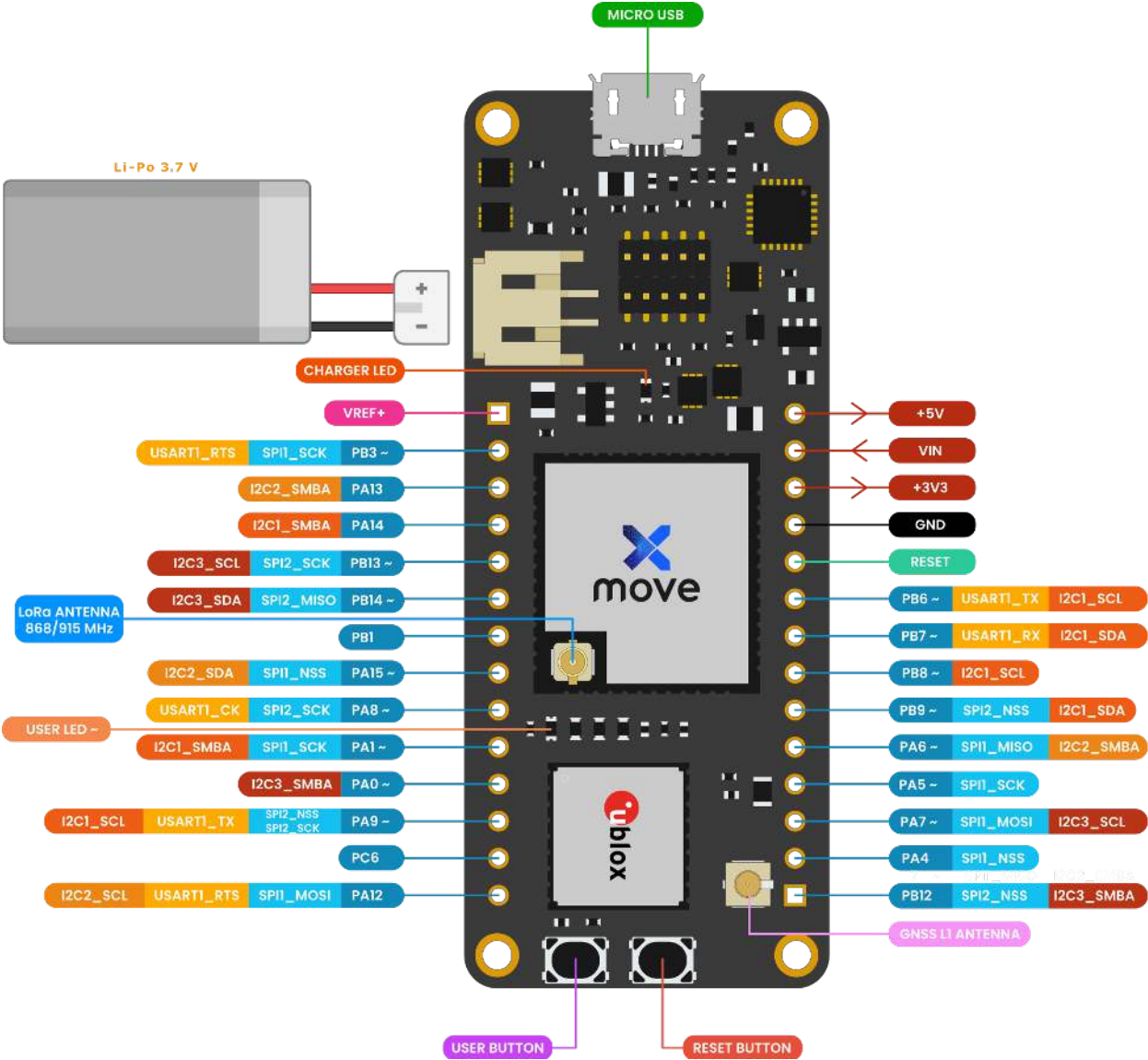

Pinout: Timers

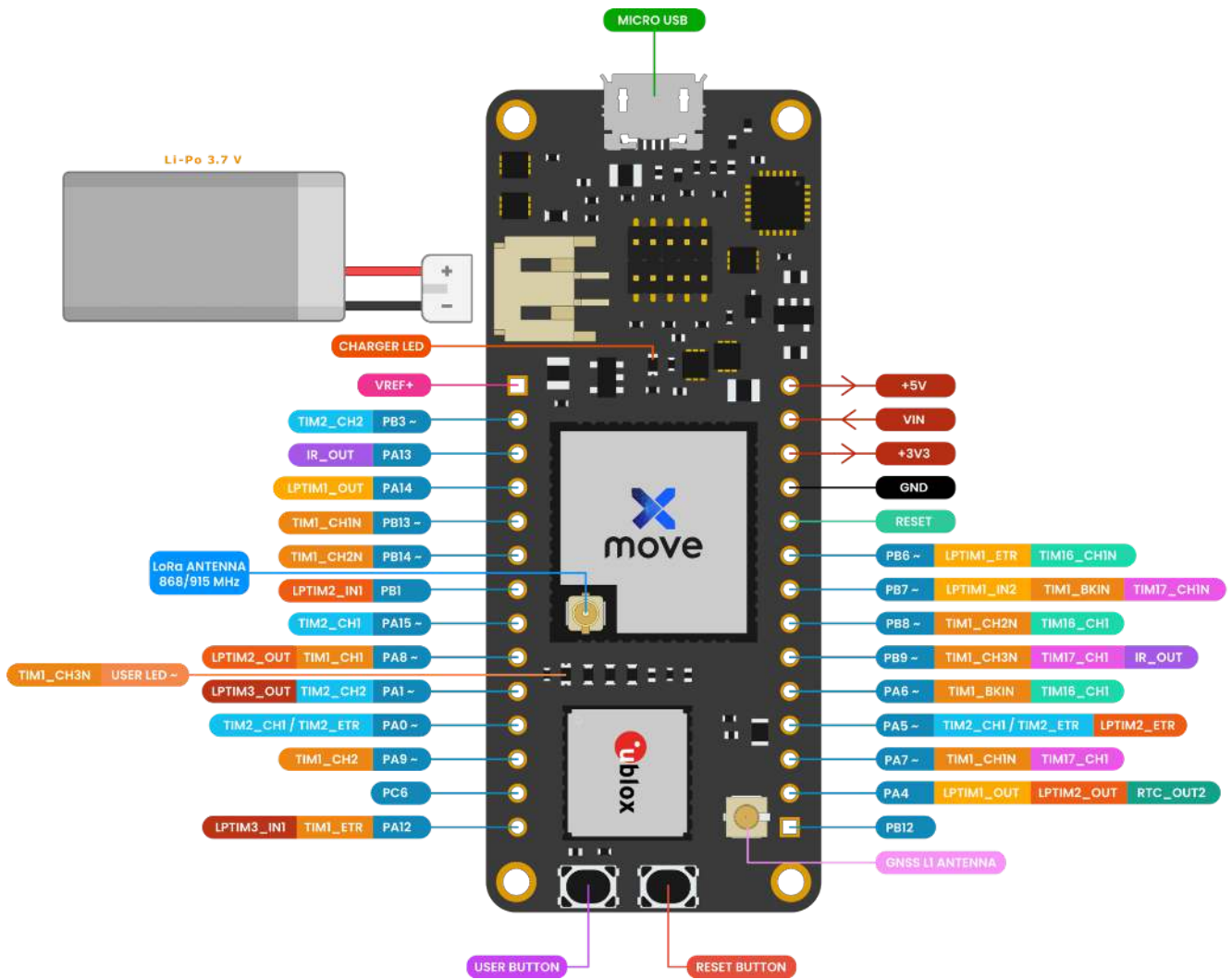

Pinout: Others

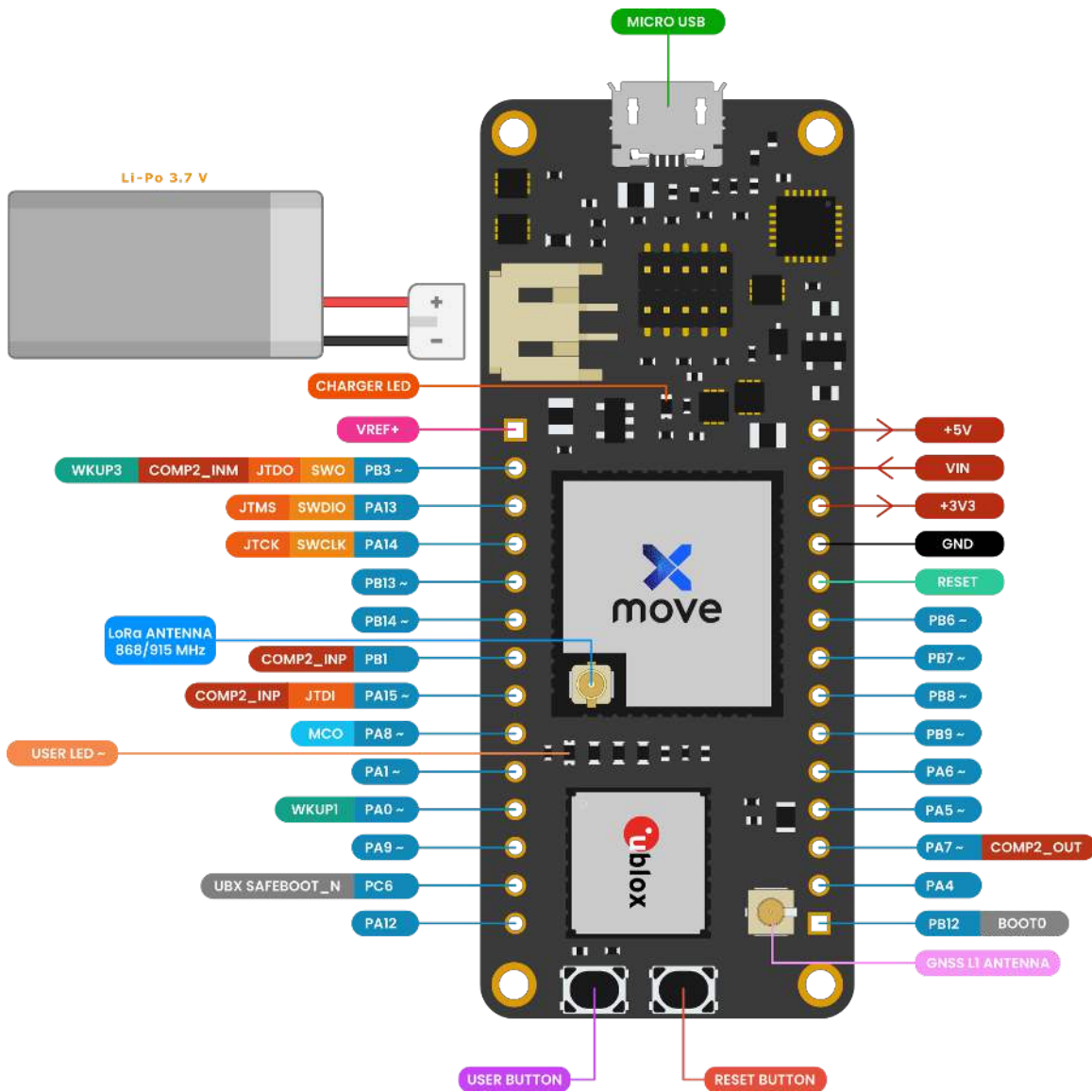

Mechanical dimensions

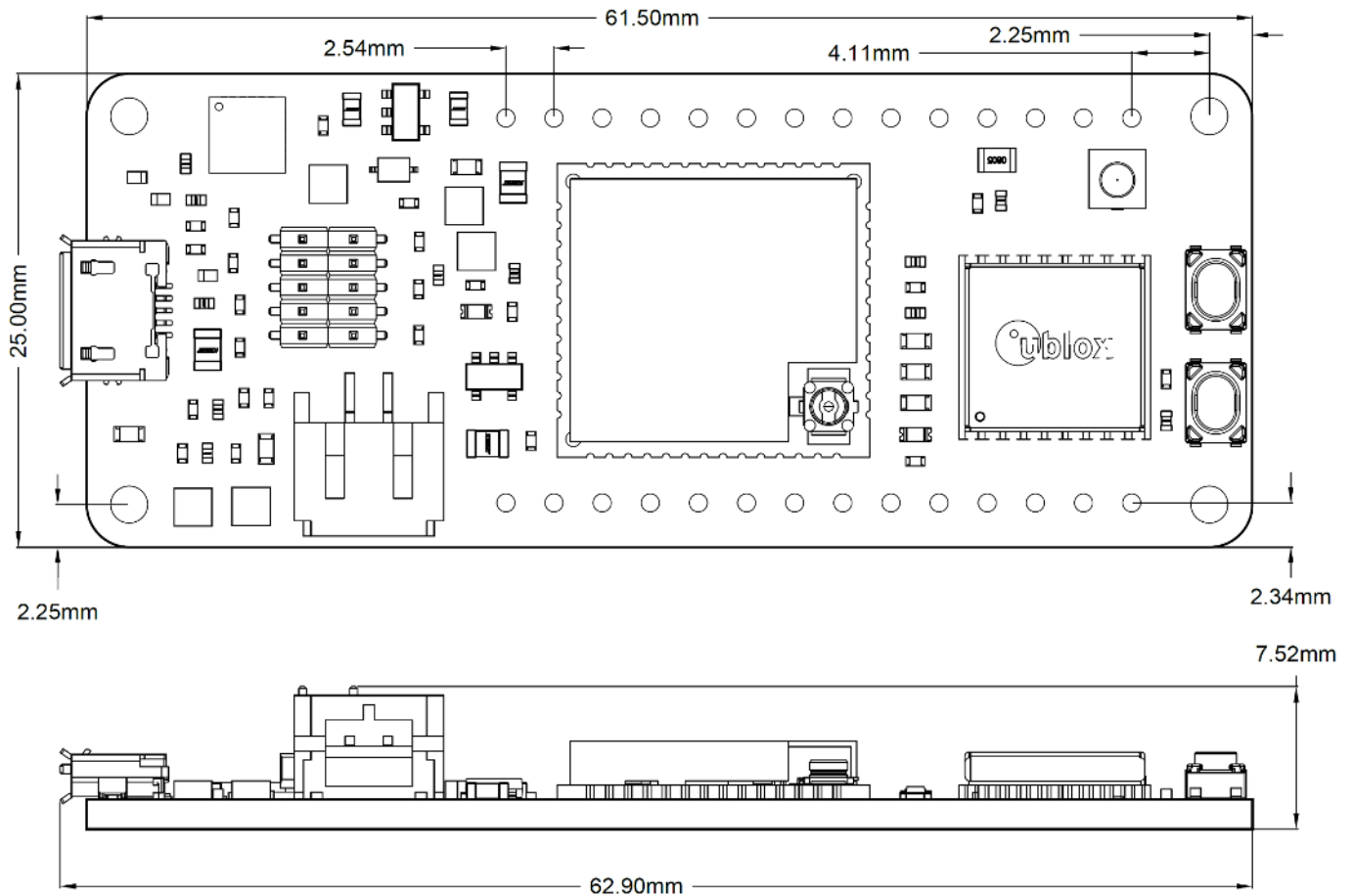

External resources

Move-X Company website: <https://www.move-x.it/>

Move-X Cicerone website: <https://www.move-x.it/cicerone-board/>

Move-X MAMWLE module website: <https://www.move-x.it/mamwle-module/>

u-blox MAX-M10S module website: <https://www.u-blox.com/en/product/max-m10-series>

u-blox CloudLocate website: <https://www.u-blox.com/en/product/cloudlocate>

Document revision

Revision 1.0 - 14/9/2022