

Low capacitance diode array

Features

- Protection of 4 lines
- Peak reverse voltage: $V_{RRM} = 9\text{ V}$ per diode
- Very low capacitance per diode: $C < 5\text{ pF}$
- Very low leakage current: $I_R < 1\text{ }\mu\text{A}$

Benefits

- Cost-effective solution compared with discrete solution
- High efficiency in ESD suppression
- No significant signal distortion thanks to very low capacitance
- High reliability offered by monolithic integration
- Lower PCB area consumption versus discrete solution

Complies with the following standards

- IEC61000-4-2 level 4
- MIL STD 883G-Method 3015-7: class 3, human body model

Applications

Where ESD and/or over and undershoot protection for datalines is required:

- Sensitive logic input protection
- Microprocessor based equipment
- Audio / video inputs
- Portable electronics
- Networks
- ISDN equipment
- USB interface

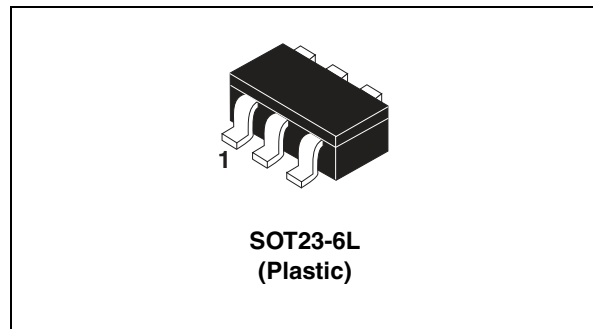
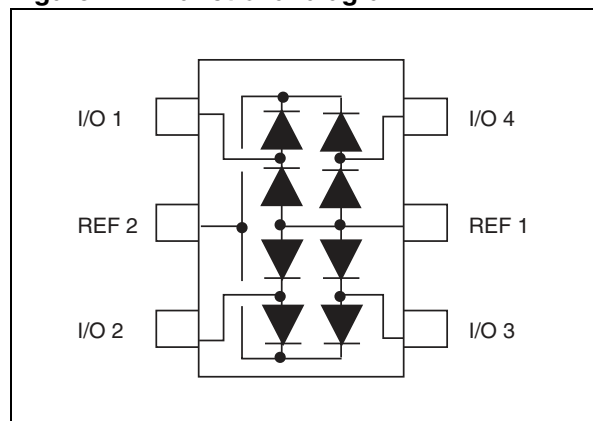

Figure 1. Functional diagram



Description

The DALC208SC6 diode array is designed to protect components which are connected to data and transmission lines from over voltages caused by electrostatic discharge (ESD) or other transients. It is a rail-to-rail protection device also suited for overshoot and undershoot suppression on sensitive logic inputs.

The low capacitance of the DALC208SC6 prevents significant signal distortion.

1 Characteristics

Table 1. Absolute maximum ratings ($T_{amb} = 25\text{ }^{\circ}\text{C}$)

Symbol	Parameter	Value	Unit	
V_{PP}	IEC61000-4-2, air discharge	15	kV	
	IEC61000-4-2, contact discharge	8		
V_{RRM}	Peak reverse voltage per diode	9	V	
ΔV_{REF}	Reference voltage gap between V_{REF2} and V_{REF1}	9	V	
$V_{In\ max.}$	Maximum operating signal input voltage	V_{REF2}	V	
$V_{In\ min.}$	Minimum operating signal input voltage	V_{REF1}	V	
I_F	Continuous forward current (single diode loaded)	200	mA	
I_{FRM}	Repetitive peak forward current ($t_p = 5\text{ ms}$, $F = 50\text{ kHz}$)	700	mA	
I_{FSM}	Surge non repetitive forward current - rectangular waveform (See curve on Figure 3.)	$t_p = 2.5\ \mu\text{s}$	6	A
		$t_p = 1\ \mu\text{s}$	2	
		$t_p = 100\ \mu\text{s}$	1	
T_{stg}	Storage temperature range	-55 to + 150	$^{\circ}\text{C}$	
T_j	Maximum junction temperature	150	$^{\circ}\text{C}$	

Table 2. Thermal resistance

Symbol	Parameter	Value	Unit
$R_{th(j-a)}$	Junction to ambient ⁽¹⁾	500	$^{\circ}\text{C/W}$

1. Device mounted on FR4 PCB with recommended footprint dimensions.

Table 3. Electrical characteristics ($T_{amb} = 25\text{ }^{\circ}\text{C}$)

Symbol	Parameter	Conditions	Typ.	Max.	Unit
V_F	Forward voltage	$I_F = 50\text{ mA}$		1.2	V
I_R	Reverse leakage current per diode	$V_R = 5\text{ V}$		1	μA
C	Input capacitance between Line and GND	See Figure 2.	7	10	pF

Figure 2. Input capacitance measurement

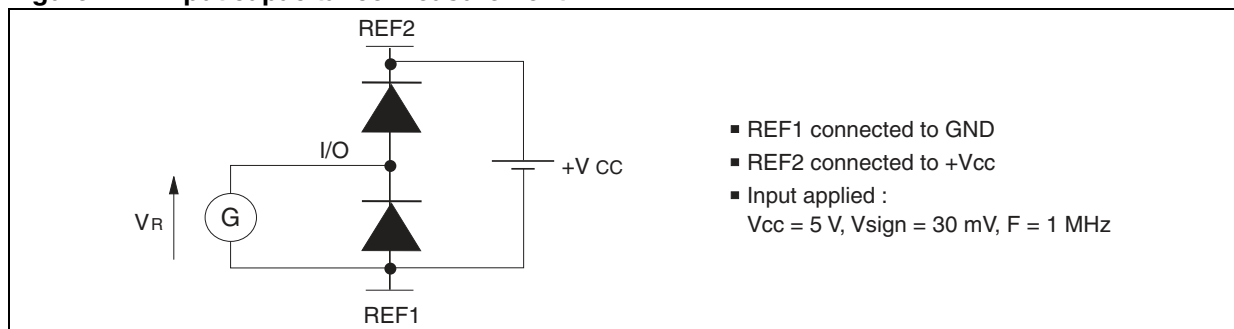

Figure 3. Maximum non-repetitive peak forward current versus rectangular pulse duration (T_j initial = 25 °C)

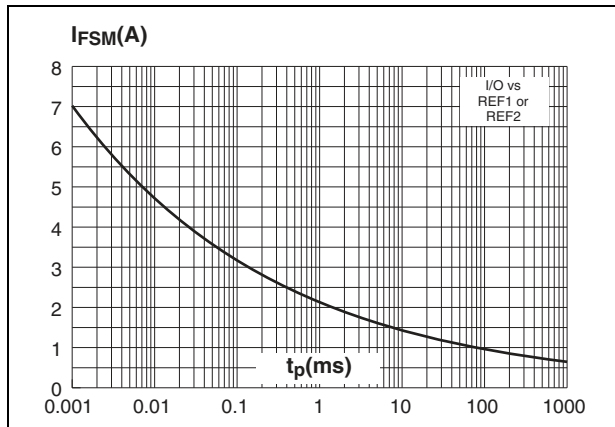

Figure 4. Reverse clamping voltage versus peak pulse current (T_j initial = 25 °C), typical values. Rectangular waveform $t_p = 2.5$ ms

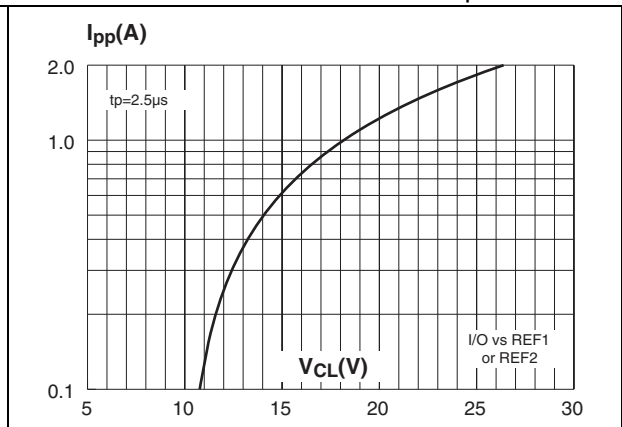

Figure 5. Variation of leakage current versus junction temperature (typical values)

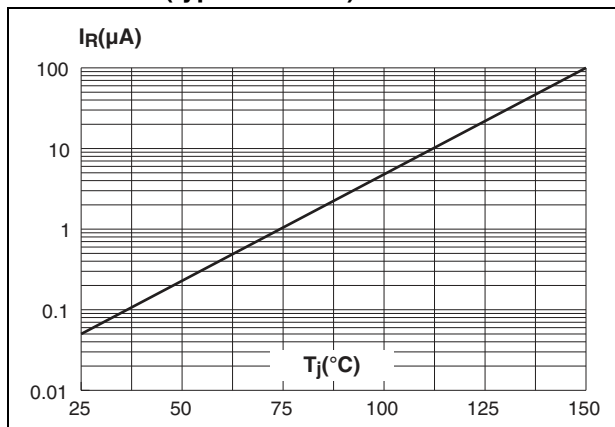

Figure 6. Input capacitance versus reverse applied voltage (typical values)

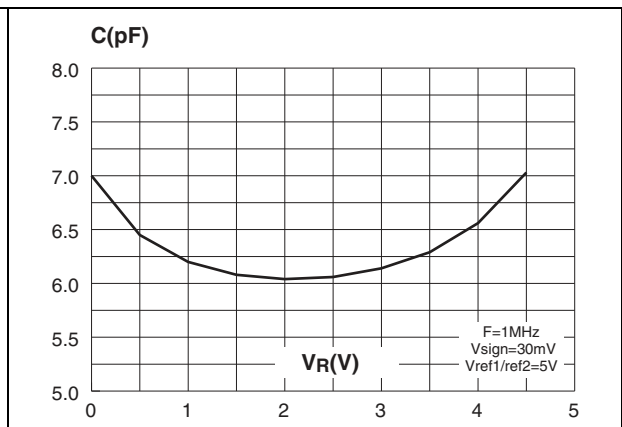
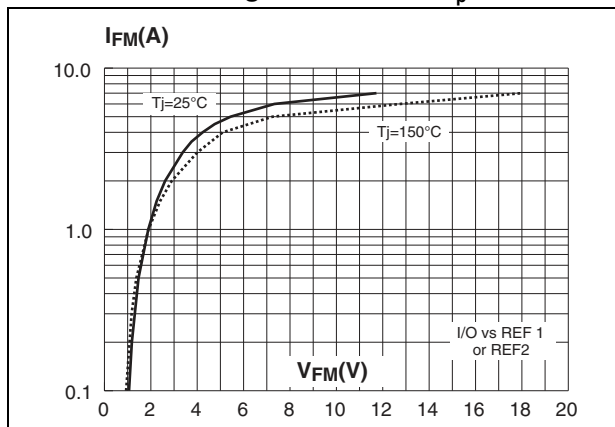

Figure 7. Peak forward voltage drop versus peak forward current (typical values), rectangular waveform $t_p = 2.5$ ms



2 Technical information

2.1 Surge protection

The DALC208SC6 is particularly optimized to perform surge protection based on the rail to rail topology.

The clamping voltage V_{CL} can be calculated as follow :

$$V_{CL+} = V_{REF2} + V_F \text{ for positive surges}$$

$$V_{CL-} = V_{REF1} - V_F \text{ for negative surges}$$

with

$$V_F = V_T + R_d \cdot I_p$$

(V_F forward drop voltage) / (V_T forward drop threshold voltage)

According to the curve [Figure 7](#) we assume that the value of the dynamic resistance of the clamping diode is typically $R_d = 0.7 \Omega$ and $V_T = 1.2 \text{ V}$.

For an IEC 61000-4-2 surge Level 4 (Contact Discharge: $V_g=8 \text{ kV}$, $R_g=330 \Omega$), $V_{REF2} = +5 \text{ V}$, $V_{REF1} = 0 \text{ V}$, and if in first approximation, we assume that : $I_p = V_g / R_g \approx 24 \text{ A}$.

So, we find:

- $V_{CL+}' +23\text{V}$
- $V_{CL-}' -18\text{V}$

Note: The calculations do not take into account phenomena due to parasitic inductances.

2.2 Surge protection application example

If we consider that the connections from the pin REF_2 to V_{CC} and from REF_1 to GND are done by two tracks of 10 mm long and 0.5 mm large; we assume that the parasitic inductances of these tracks are about 6 nH. So when an IEC 61000-4-2 surge occurs, due to the rise time of this spike ($t_r = 1 \text{ ns}$), the voltage V_{CL} has an extra value equal to $L_w \cdot di/dt$.

The di/dt is calculated as: $di/dt = I_p/t_r \approx 24 \text{ A/ns}$

The overvoltage due to the parasitic inductances is: $L_w \cdot di/dt = 6 \times 24 \approx 144 \text{ V}$

By taking into account the effect of these parasitic inductances due to unsuitable layout, the clamping voltage will be :

- $V_{CL+} = +23 + 144 \approx 167\text{V}$
- $V_{CL-} = -18 - 144 \approx -162\text{V}$

We can reduce as much as possible these phenomena with simple layout optimization.

It's the reason why some recommendations have to be followed (See [Section 2.3: How to ensure good ESD protection](#)).

Figure 8. ESD behavior: parasitic phenomena due to unsuitable layout

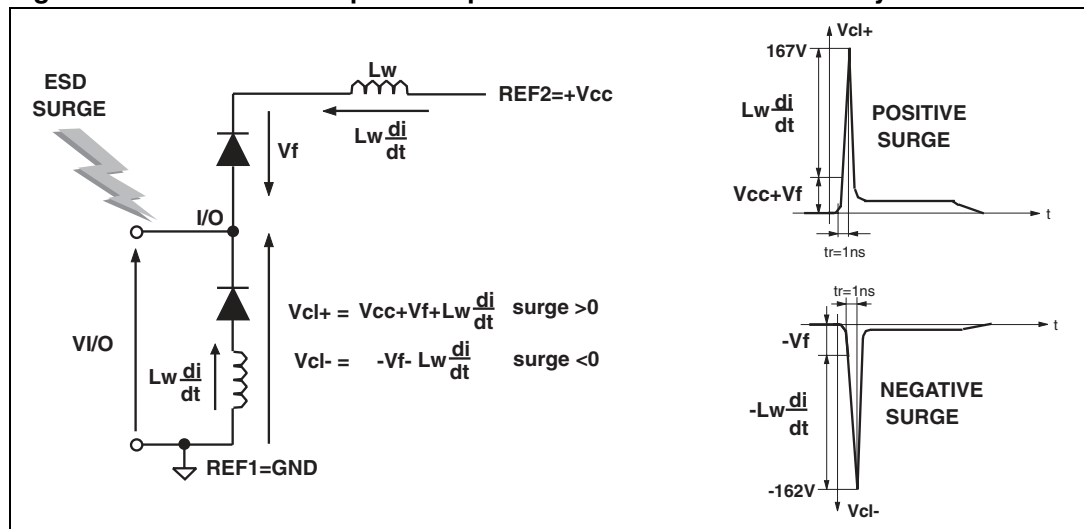

2.3 How to ensure good ESD protection

While the DALC208SC6 provides a high immunity to ESD surge, an efficient protection depends on the layout of the board. In the same way, with the rail to rail topology, the track from the V_{REF2} pin to the power supply $+V_{CC}$ and from the V_{REF1} pin to GND must be as short as possible to avoid over voltages due to parasitic phenomena. See [Figure 8](#).

It's often harder to connect the power supply near to the DALC208SC6 unlike the ground thanks to the ground plane that allows a short connection.

To ensure the same efficiency for positive surges when the connections can't be short enough, we recommend putting a capacitance of 100 nF close to the DALC208SC6, between V_{REF2} and ground, to prevent these kinds of overvoltage disturbances. See [Figure 9](#).

The addition of this capacitance will allow a better protection by providing a constant voltage during a surge.

[Figure 10](#), [Figure 11](#), and [Figure 12](#) show the improvement of the ESD protection according to the recommendations described above.

Figure 9. ESD behavior: optimized layout and add of a capacitance of 100 nF

Figure 10. ESD behavior: measurement conditions (with coupling capacitance)

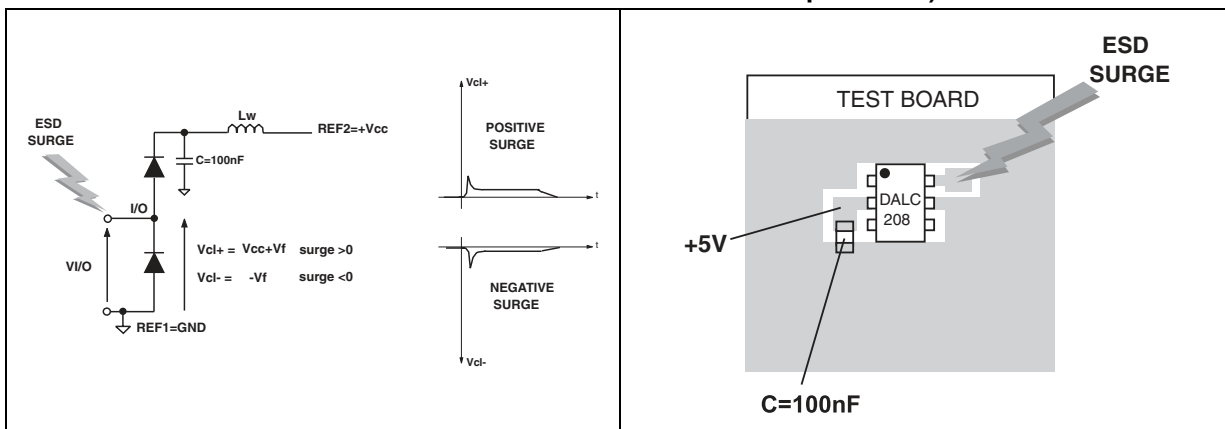
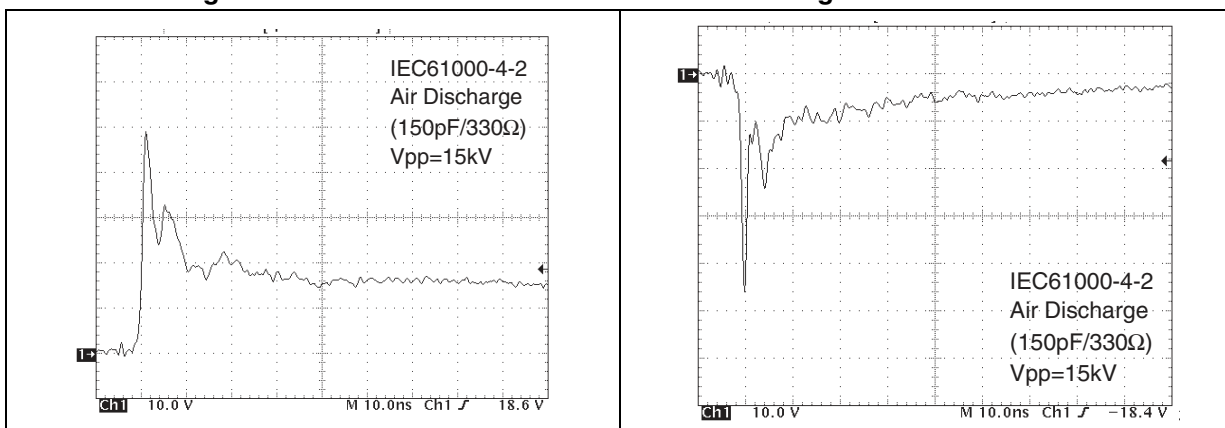

Figure 11. Remaining voltage after the DALC208SC6 during positive ESD surge

Figure 12. Remaining voltage after the DALC208SC6 during negative ESD surge



Important

A precaution to take is to put the protection device as close as possible to the disturbance source (generally the connector).

Note: The measurements have been done with the DALC208SC6 in open circuit.

3 Crosstalk behavior

3.1 Crosstalk phenomena

Figure 13. Crosstalk phenomena

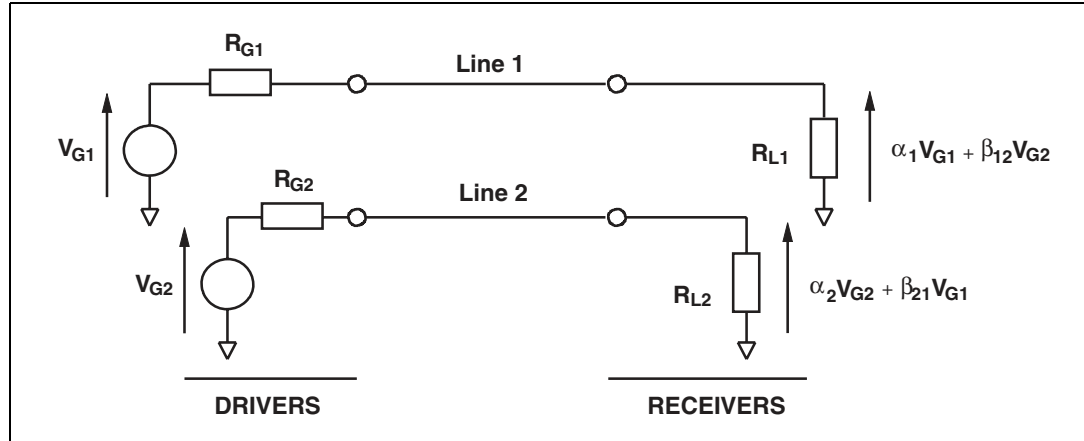

The crosstalk phenomenon is due to the coupling between 2 lines. The coupling factor (β_{12} or β_{21}) increases when the gap across lines decreases, particularly in silicon dice. In the example in *Figure 13* the expected signal on load R_{L2} is $\alpha_2 V_{G2}$, in fact the real voltage at this point has got an extra value $\beta_{21} V_{G1}$. This part of the V_{G1} signal represents the effect of the crosstalk phenomenon of line 1 on line 2. This phenomenon has to be taken into account when the drivers impose fast digital data or high frequency analog signals in the disturbing line. The disturbed line will be more affected if it works with low voltage signal or high load impedance (few $k\Omega$). The following sections give the value of both digital and analog crosstalk.

3.2 Digital crosstalk

Figure 14. Digital crosstalk measurements

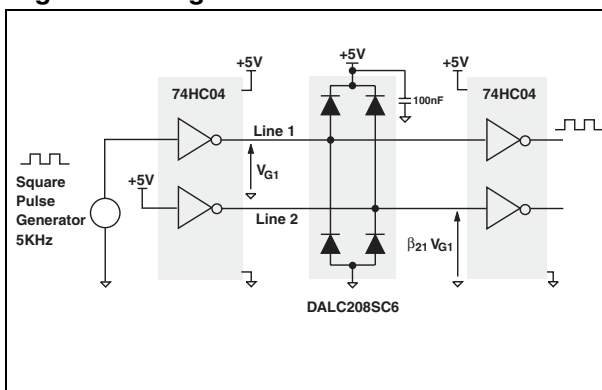

Figure 15. Digital crosstalk results

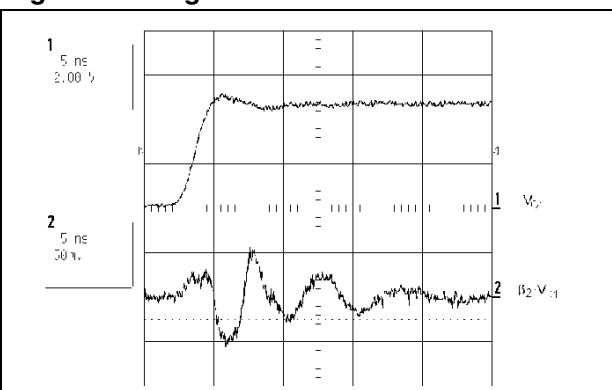

Figure 14 shows the measurement circuit used to quantify the crosstalk effect in a classical digital application. *Figure 15* shows that in such a condition: signal from 0 V to 5 V and a rise time of 5 ns, the impact on the disturbed line is less than 100mV peak to peak. No data disturbance was noted on the concerned line. The same results were obtained with falling edges.

Note: The measurements have been done in the worst case i.e. on two adjacent cells (I/O1 and I/O4).

3.3 Analog crosstalk

Figure 16. Analog crosstalk measurements

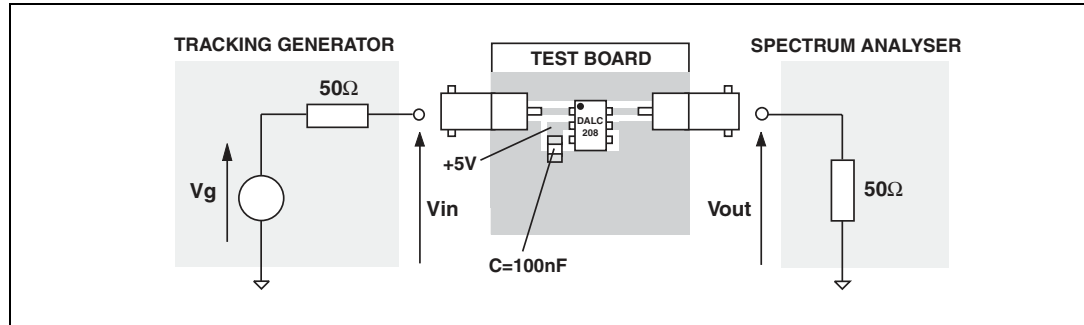

Figure 16 shows the measurement circuit for the analog application. For the usual frequency range of analog signals (up to 100MHz) the effect on disturbed line is less than -45 dBm. See Figure 17.

Figure 17. Analog crosstalk results

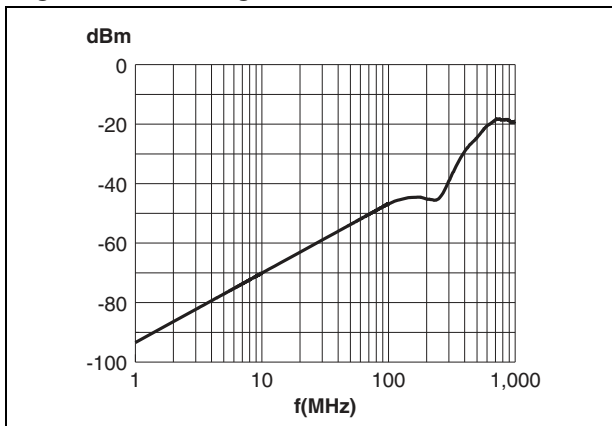
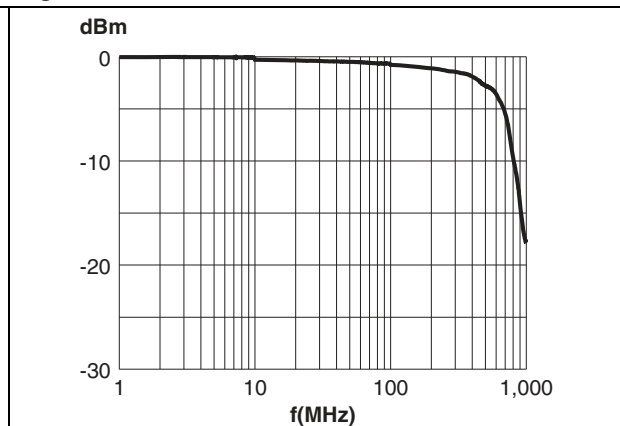

Figure 18. DALC208SC6 attenuation



As the DALC208SC6 is designed to protect high speed data lines, it must ensure a good transmission of operating signals. The attenuation curve give such an information.

Figure 18 shows that the DALC208SC6 is well suitable for data line transmission up to 100 Mbit/s while it works as a filter for undesirable signals such as GSM carrier (900 MHz).

4 Application examples

Figure 19. Video line protection

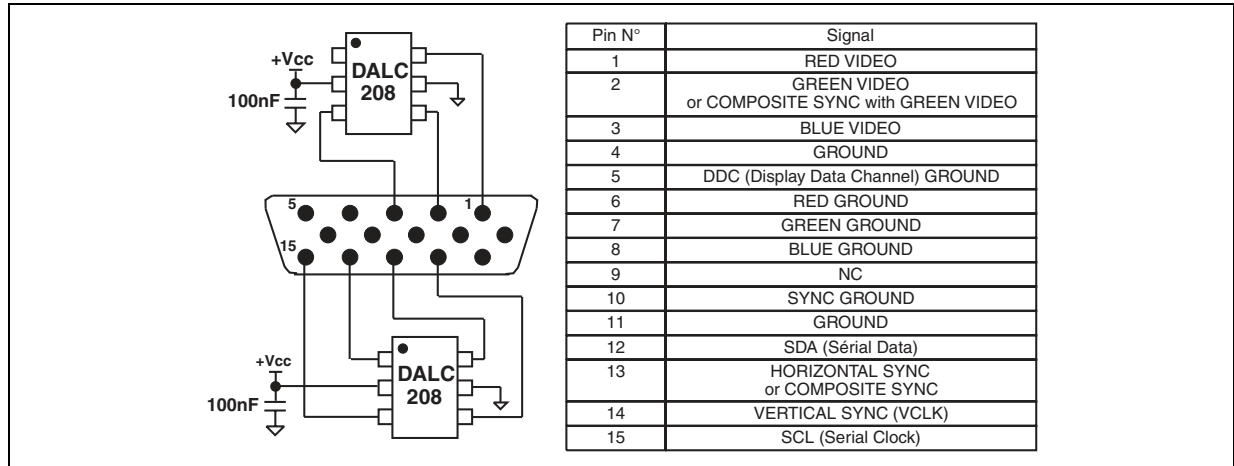

Figure 20. T1/E1 protection

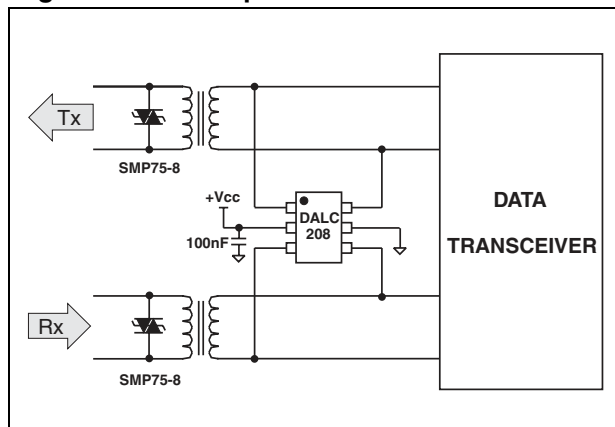

Figure 21. USB port protection

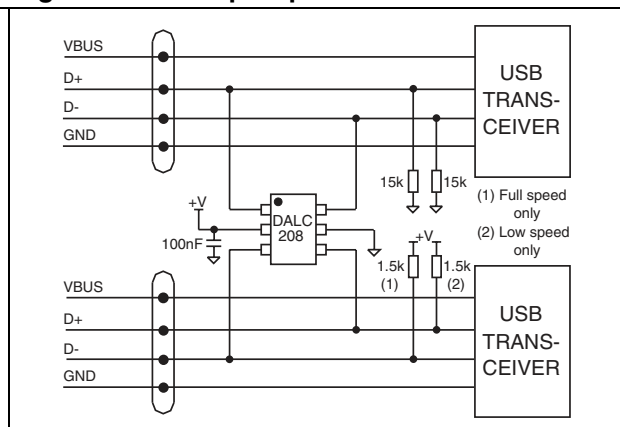
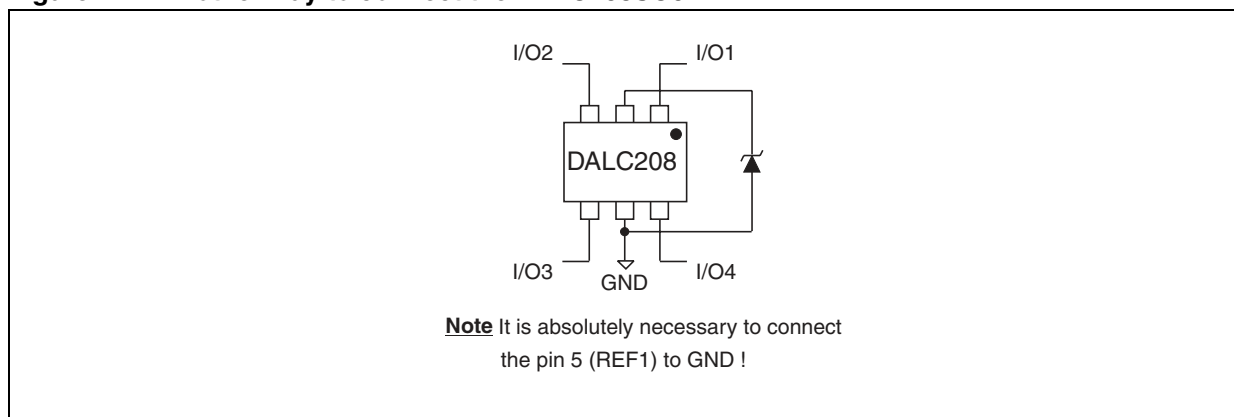

Figure 22. Another way to connect the DALC208SC6



5 PSpice model

Figure 23 shows the PSpice model of one DALC208SC6 cell. In this model, the diodes are defined by the PSpice parameters given in Table 4.

Figure 23. PSpice model of one DALC208SC6 cell

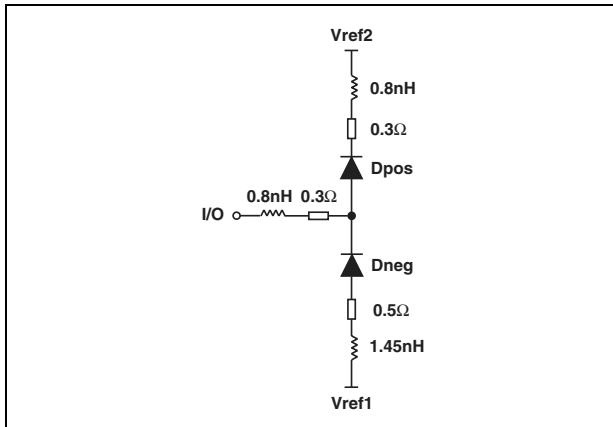
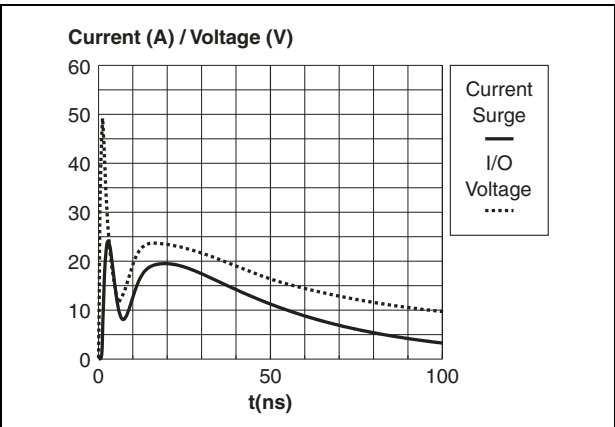

Figure 24. PSpice model simulation: surge > 0 IEC 61000-4-2 contact discharge response



Note: This simulation model is available only for an ambient temperature of 27 °C. The simulations done (Figure 24, Figure 25 and Figure 26) show that the PSpice model is close to the product behavior.

Figure 25. PSpice model simulation: surge < 0 IEC61000-4-2 contact discharge response

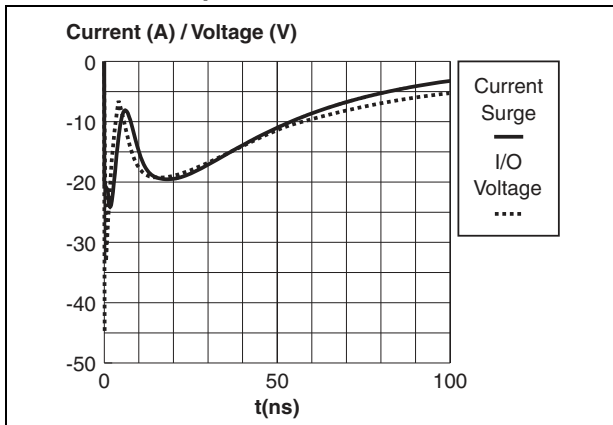

Figure 26. Attenuation comparison

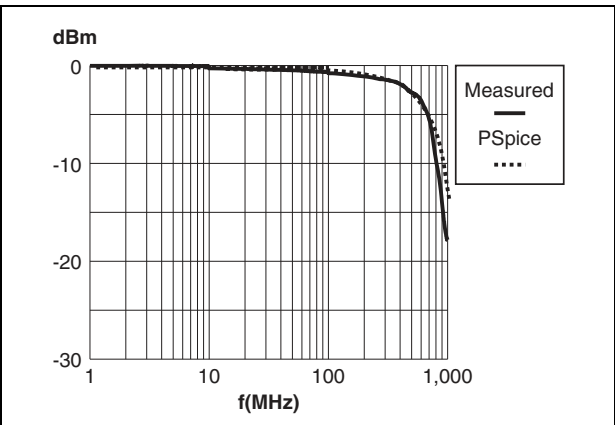

Table 4. PSpice parameter

Parameter	D _{POS}	D _{NEG}
BV	9	9
CJO	7p	7p
IBV	1u	1u
IKF	28.357E-3	1000
IS	118.78E-15	5.6524E-9
ISR	100E-12	472.3E-9
M	0.3333	0.3333
N	1.3334	2.413
NR	2	2
RS	0.68377	0.71677
VJ	0.6	0.6

6 Package information

- Epoxy meets UL94, V0

In order to meet environmental requirements, ST offers these devices in ECOPACK® packages. These packages have a lead-free second level interconnect. The category of second level interconnect is marked on the inner box label, in compliance with JEDEC Standard JESD97. The maximum ratings related to soldering conditions are also marked on the inner box label. ECOPACK is an ST trademark. ECOPACK specifications are available at www.st.com.

Table 5. SOT23-6L dimensions

Ref.	Dimensions					
	Millimeters			Inches		
	Min.	Typ.	Max.	Min.	Typ.	Max.
A	0.90		1.45	0.035		0.057
A1	0		0.10	0		0.004
A2	0.90		1.30	0.035		0.051
b	0.35		0.50	0.014		0.020
c	0.09		0.20	0.004		0.008
D	2.80		3.05	0.11		0.118
E	1.50		1.75	0.059		0.069
e		0.95			0.037	
H	2.60		3.00	0.102		0.118
L	0.10		0.60	0.004		0.024
θ	0°		10°	0°		10°

Figure 27. Footprint (dimensions in mm)

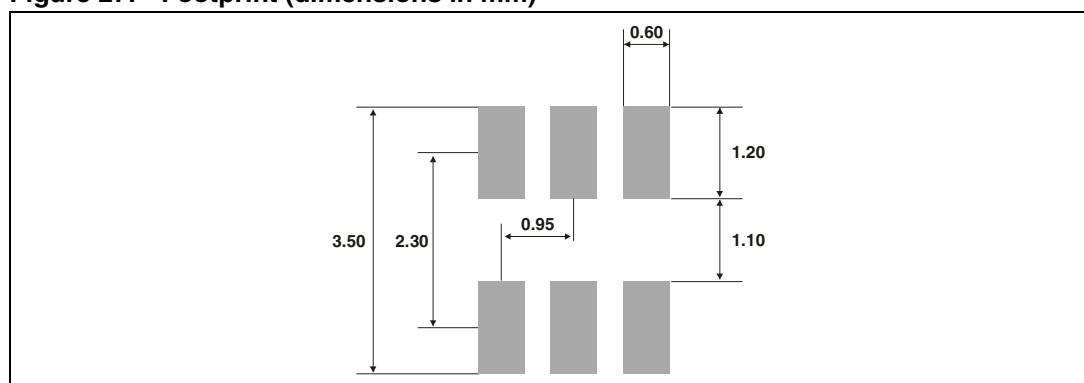

7 Ordering information

Table 6. Ordering information

Order code	Marking	Package	Weight	Base qty	Packing mode
DALC208SC6	DALC	SOT23-6L	16.7 mg	3000	Tape and reel

8 Revision history

Table 7. Document revision history

Date	Revision	Changes
Feb-2002	5C	Last update.
28-Oct-2004	6	SOT23-6L package dimensions change for reference "D" from 3.0 millimeters (0.118 inches) to 3.05 millimeters (0.120 inches).
20-Mar-2008	7	Reformatted to current standard. Added ECOPACK paragraph.

Please Read Carefully:

Information in this document is provided solely in connection with ST products. STMicroelectronics NV and its subsidiaries ("ST") reserve the right to make changes, corrections, modifications or improvements, to this document, and the products and services described herein at any time, without notice.

All ST products are sold pursuant to ST's terms and conditions of sale.

Purchasers are solely responsible for the choice, selection and use of the ST products and services described herein, and ST assumes no liability whatsoever relating to the choice, selection or use of the ST products and services described herein.

No license, express or implied, by estoppel or otherwise, to any intellectual property rights is granted under this document. If any part of this document refers to any third party products or services it shall not be deemed a license grant by ST for the use of such third party products or services, or any intellectual property contained therein or considered as a warranty covering the use in any manner whatsoever of such third party products or services or any intellectual property contained therein.

UNLESS OTHERWISE SET FORTH IN ST'S TERMS AND CONDITIONS OF SALE ST DISCLAIMS ANY EXPRESS OR IMPLIED WARRANTY WITH RESPECT TO THE USE AND/OR SALE OF ST PRODUCTS INCLUDING WITHOUT LIMITATION IMPLIED WARRANTIES OF MERCHANTABILITY, FITNESS FOR A PARTICULAR PURPOSE (AND THEIR EQUIVALENTS UNDER THE LAWS OF ANY JURISDICTION), OR INFRINGEMENT OF ANY PATENT, COPYRIGHT OR OTHER INTELLECTUAL PROPERTY RIGHT.

UNLESS EXPRESSLY APPROVED IN WRITING BY AN AUTHORIZED ST REPRESENTATIVE, ST PRODUCTS ARE NOT RECOMMENDED, AUTHORIZED OR WARRANTED FOR USE IN MILITARY, AIR CRAFT, SPACE, LIFE SAVING, OR LIFE SUSTAINING APPLICATIONS, NOR IN PRODUCTS OR SYSTEMS WHERE FAILURE OR MALFUNCTION MAY RESULT IN PERSONAL INJURY, DEATH, OR SEVERE PROPERTY OR ENVIRONMENTAL DAMAGE. ST PRODUCTS WHICH ARE NOT SPECIFIED AS "AUTOMOTIVE GRADE" MAY ONLY BE USED IN AUTOMOTIVE APPLICATIONS AT USER'S OWN RISK.

Resale of ST products with provisions different from the statements and/or technical features set forth in this document shall immediately void any warranty granted by ST for the ST product or service described herein and shall not create or extend in any manner whatsoever, any liability of ST.

ST and the ST logo are trademarks or registered trademarks of ST in various countries.

Information in this document supersedes and replaces all information previously supplied.

The ST logo is a registered trademark of STMicroelectronics. All other names are the property of their respective owners.

© 2008 STMicroelectronics - All rights reserved

STMicroelectronics group of companies

Australia - Belgium - Brazil - Canada - China - Czech Republic - Finland - France - Germany - Hong Kong - India - Israel - Italy - Japan - Malaysia - Malta - Morocco - Singapore - Spain - Sweden - Switzerland - United Kingdom - United States of America

www.st.com