

51526-58		REVISIONS	
LTR	DESCRIPTION	DATE	APPVD
C	(CL 11) SEE OBSOLETE RECORD DRAWING. REDESIGNED AND REDRAWN SAME SIZE SEE ECN: <b>84156</b>	1-10-98	GJO

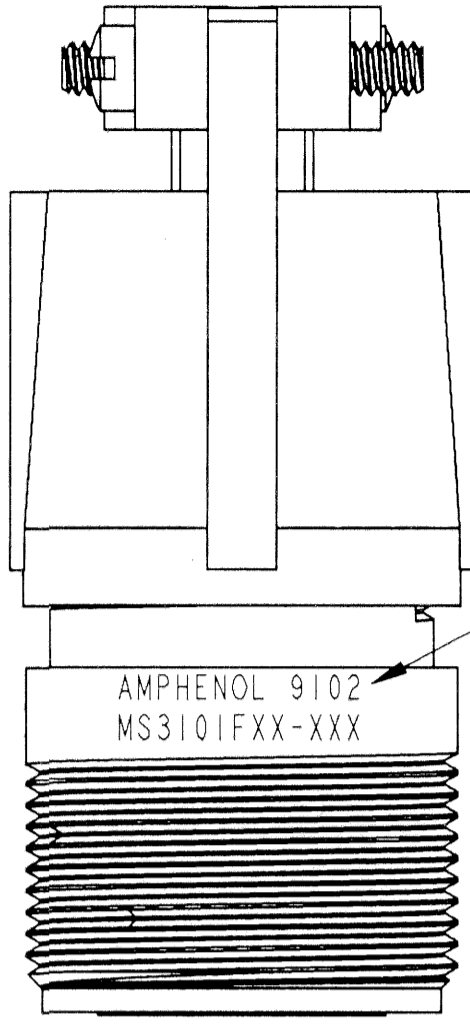

5  
BLACK INK STAMP "AMPHENOL",  
DATE CODE (PER 9-3895) & MS  
NUMBER APPROX .062 HIGH  
PER 9-2811.  
EXAMPLE:  
AMPHENOL 9102 MS3101F20-12P

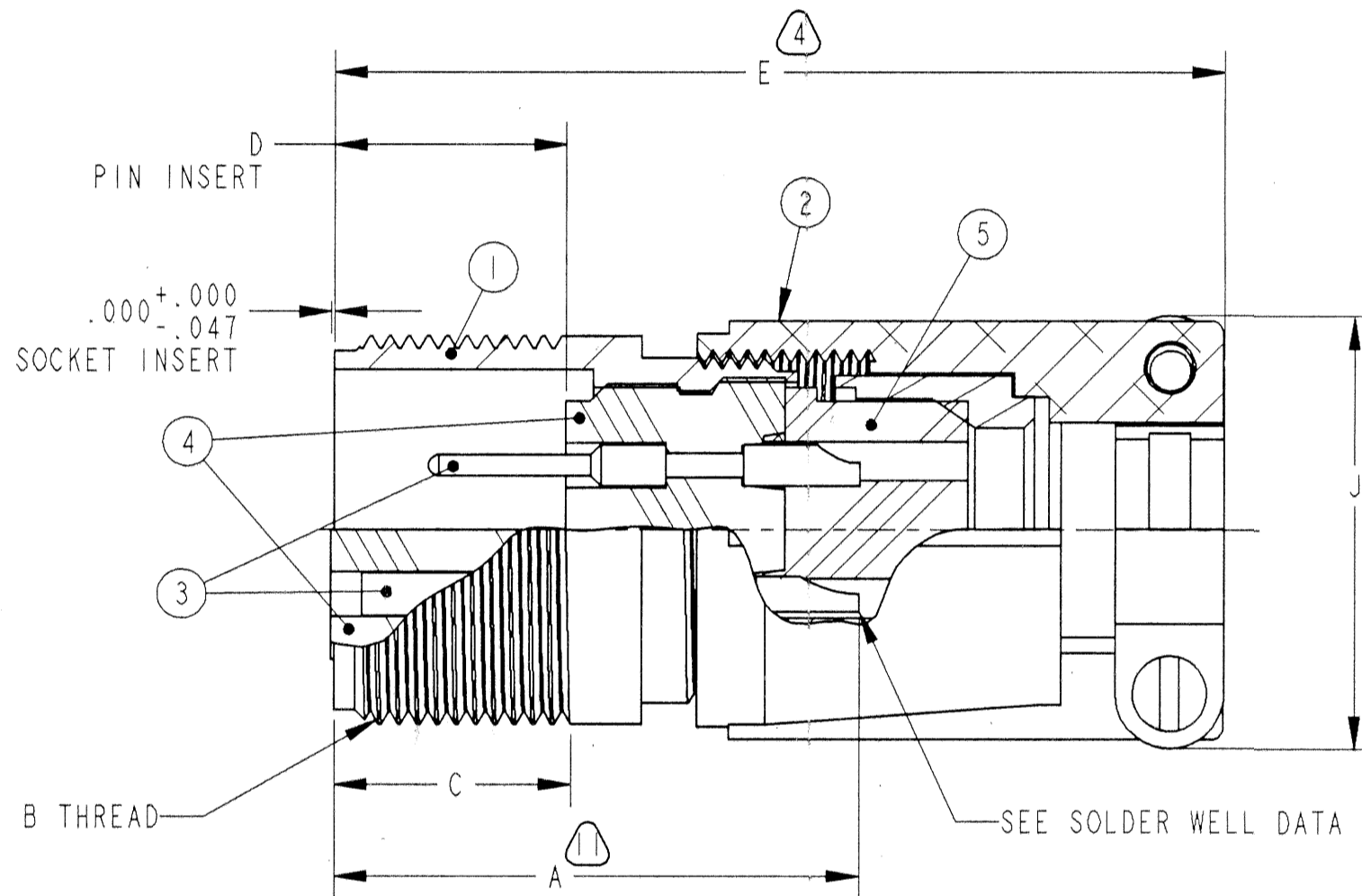
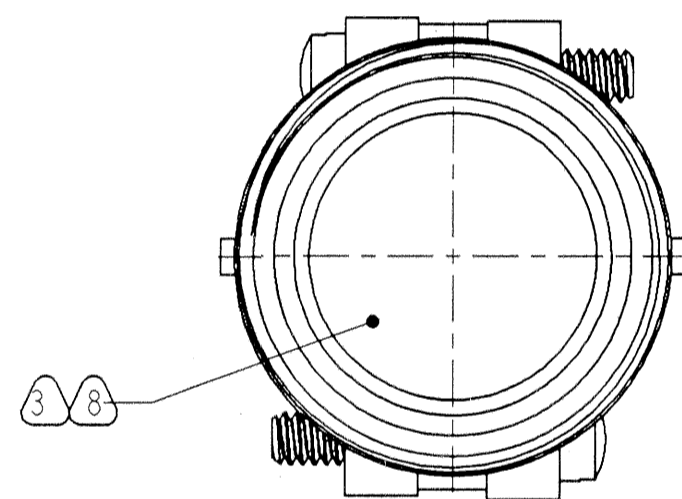

SOLDER WELL DATA						THERMOCOUPLE	
CONTACT SIZE	0	4	8	12	16	12	16
WELL DIA	.469 <sup>+</sup> .005 -.003	.332 <sup>+</sup> .005 -.003	.209 <sup>+</sup> .004 -.002	.116 <sup>+</sup> .004 -.002	.078 <sup>+</sup> .004 -.002	.125 <sup>+</sup> .004 -.002	.094 <sup>+</sup> .004 -.002
WELL DEPTH	.625	.625	.500	.375	.250	.250	.188

14

CONTACT DATA (WHERE APPLICABLE)	
THERMOCOUPLE	
MATERIAL	IDENTIFICATION
CHROMEL	WHITE
ALUMEL	GREEN
IRON	BLACK
CONSTANTAN	YELLOW
INSERT ARRANGEMENTS CONTAINING THERMOCOUPLE CONTACTS MUST HAVE SUCH CONTACTS ASSEMBLED INTO THE INSERT IN PROPER LOCATIONS AS SPECIFIED BY APPLICABLE DRAWINGS MIL-STD-1651	

SEE SHEET 2.

**NOTES:**

THE USE OF THIS DOCUMENT IS UNLIMITED. HOWEVER, DOCUMENTS REFERENCED HEREON MAY CONTAIN LIMITED RIGHTS DATA.

COMPANY ID: 4	CODED/MS/CUST: Y	N/A
INTERNAL: N	LOT NO: N	N/A
DATE CODE: 9-3895	SEE DRAW: N	N/A
STAMPING DATA		NEXT ASSEMBLY

UNLESS OTHERWISE SPECIFIED	SPECIFICATIONS	POS	QTY	PART NUMBER	DESCRIPTION	NOTE	
LINEAR DIMENSIONS ARE IN INCHES TOLERANCES: .XXXX = ±.0005 .XXX = ±.010 .XX = ±.03 .X = ±.1 ANGLES = ±2° OTHER STANDARDS PER 9-3800 AND DOD-D-1000 THIRD ANGLE PROJECTION	MATERIAL SPEC.	APPROVALS		DATE	<b>AMPHENOL CORPORATION</b> <small>SIDNEY, N.Y. 13838-1395</small>		
	N/A	PREPARED	WHITNEY	11-4-69			
	PROCESS SPEC.	CHECKED	MENDEOLA	11-18-69	CONNECTOR, ELECTRICAL RECEPTACLE, TYPE MS3101F		
	TEST: 9-3106-5	APPROVED	R. W. TYLER	11-6-69	SIZE	FSCM NO.	DOCUMENT NO.
	ASSY: 9-3103-1	APPROVED	M. HARRISON	11-19-69	C	77820	10-474108/150
PRO/ENG INFORMATION		SCALE: NONE		REF: 10-329820/839	SHEET 1 OF 2		
10-474108_150.ASSEM		10-474108_150					

5	1	SEE COLUMN	GROMMET
4	1	SEE COLUMN	INSERT
3		SEE NOTE 12	CONTACTS
2	1	SEE COLUMN	BACKSHELL KIT
1	1	SEE COLUMN	SHELL

ASSEMBLY NUMBER	MS NUMBER	INSERT	GROMMET	SHELL	BACKSHELL KIT	A +.050 -.060	B THREAD CLASS 2A (PLATED)	C MIN FULL THREAD	D ±.031	E MAX	J MAX
10-474108-( )	3101F-8S-( )	NOT AVAILABLE									
10-474110-( )	3101F-10S-( )	NOT AVAILABLE									
10-474111-( )	3101F-10SL-( )	10-74811-( )	10-60711-( )	10-37261-11	10-584182-113	1.094	.6250-24 UNEF	.406	.484	2.192	.896
10-474112-( )	3101F-12S-( )	10-74812-( )	10-60712-( )	10-37261-12	10-584182-113	1.094	.7500-20 UNEF	.422	.484	2.192	.896
10-474113-( )	3101F-12-( )	10-74813-( )	10-60713-( )	10-37261-13	10-584182-113	1.532	.7500-20 UNEF	.656	.672	2.536	.896
10-474114-( )	3101F-14S-( )	10-74814-( )	10-60714-( )	10-37261-14	10-584185-143	1.094	.8750-20 UNEF	.391	.484	2.192	1.021
10-474115-( )	3101F-14-( )	10-74815-( )	10-60715-( )	10-37261-15	10-584185-143	1.532	.8750-20 UNEF	.625	.672	2.536	1.021
10-474116-( )	3101F-16S-( )	10-74816-( )	10-60716-( )	10-37261-16	10-584187-163	1.094	1.0000-20 UNEF	.391	.484	2.192	1.151
10-474117-( )	3101F-16-( )	10-74817-( )	10-60717-( )	10-37261-17	10-584188-173	1.532	1.0000-20 UNEF	.625	.672	2.536	1.151
10-474118-( )	3101F-18-( )	10-74818-( )	10-60718-( )	10-37261-18	10-584189-183	1.532	1.1250-18 UNEF	.625	.672	2.661	1.242
10-474120-( )	3101F-20-( )	10-74820-( )	10-60720-( )	10-37261-20	10-584190-203	1.532	1.2500-18 UNEF	.625	.672	2.661	1.499
10-474122-( )	3101F-22-( )	10-74822-( )	10-60722-( )	10-37261-22	10-584191-223	1.532	1.3750-18 UNEF	.625	.672	2.661	1.499
10-474124-( )	3101F-24-( )	10-74824-( )	10-60724-( )	10-37261-24	10-584192-243	1.532	1.5000-18 UNEF	.625	.672	2.739	1.781
10-474128-( )	3101F-28-( )	10-74828-( )	10-60728-( )	10-37261-28	10-584193-283	1.532	1.7500-18 UNS	.625	.672	2.739	1.781
10-474132-( )	3101F-32-( )	10-74832-( )	10-60732-( )	10-37261-32	10-584194-323	1.532	2.0000-18 UNS	.625	.672	3.128	2.087
10-474136-( )	3101F-36-( )	10-74836-( )	10-60736-( )	10-37261-36	10-584195-363	1.532	2.2500-16 UN	.625	.672	3.128	2.281
10-474140-( )	3101F-40-( )	10-74840-( )	10-60740-( )	10-37261-40	10-584196-403	1.532	2.5000-16 UN	.625	.672	3.128	2.550
10-474141/50		NOT AVAILABLE									

6

- 6. TO COMPLETE ASSEMBLY NUMBER AND MS NUMBER, ADD APPLICABLE INSERT ARRANGEMENT SUFFIX TO BASE NUMBERS LISTED ABOVE. (FOR ALTERNATE ARRANGEMENTS, REFER TO 9-2437).
- 5. SEE WORK ORDER FOR PERMISSIBLE ADDITIONAL OR ALTERNATE STAMPING.
- 4. DIMENSION INDICATES FINAL INSTALLATION. FOR STORAGE AND SHIPPING, NUT, SLEEVE AND GROMMET MAY BE SHIPPED UNASSEMBLED.
- 3. FOR CONTACT SIZE, SPACING AND SERVICE RATING, SEE DRAWINGS, MIL-STD-1651.
- 2. PACKAGE PER PRODUCTION PROCESS SHEET.
- 1. ALL UNUSED GROMMET HOLES MUST BE FILLED WITH APPROPRIATE SIZE SEALING PLUGS.

- 15. SOME INSERTS AND GROMMETS ARE TOOLED UNDER A +50 PART NUMBER. CONSULT PARTS LIST FOR VERIFICATION.
- 14. INDICATED THERMOCOUPLE CONTACT DATA IS APPLICABLE ONLY TO 10-474117-13P/S, 10-474118-15P/S (AND THEIR ALTERNATE ARRANGEMENTS) WHICH ARE THE ONLY THERMOCOUPLE ARRANGEMENTS AVAILABLE IN THIS SERIES.
- 13. SHIP CONNECTOR WITH SEALING PLUGS UNASSEMBLED.
- 12. SEE SEPARATE PARTS LIST FOR COMPONENT PART NUMBERS AND QUANTITIES.
- 11. INCREASE "A" DIMENSION BY .312 FOR SIZE "0" CONTACT ONLY.
- 10. UNITS ILLUSTRATED MEET THE MATERIAL AND FINISH REQUIREMENTS OF MIL-C-5015.
- 9. ALL LOCKWIRE HOLES ARE .045 DIAMETER MINIMUM
- 8. INSERTS AND CONTACTS ARE REMOVABLE.
- 7. SEE DRAWING 10-474608/650 AND OTHERS FOR REQUIRED MATING PLUG ASSEMBLIES.

NOTES:

THE USE OF THIS DOCUMENT IS UNLIMITED. HOWEVER, DOCUMENTS REFERENCED HEREON MAY CONTAIN LIMITED RIGHTS DATA.

SIZE <b>C</b>	FSCW NO. <b>77820</b>	DOCUMENT NO. <b>10-474108/150</b>	REV. <b>C</b>
SCALE: NONE		REF: 10-329820/839	SHEET 2 OF 2

10-474108/150 2 OF 2