

REVISIONS

P	LTR	DESCRIPTION	DATE	DWN	APVD
	A	NEW RELEASE PER ECO-14-009839	07JUL2014	DM	DM
	A1	REVISED PER ECO-15-002760	20FEB2015	PS	DM
	A2	REVISED PER PCN E-18-006791	03MAY2018	SM	DM
	A3	REVISED PER PCN E-20-005917	22APR2020	AP	IG

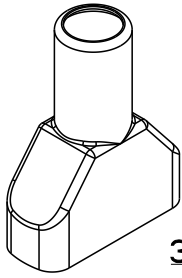

3D VIEW

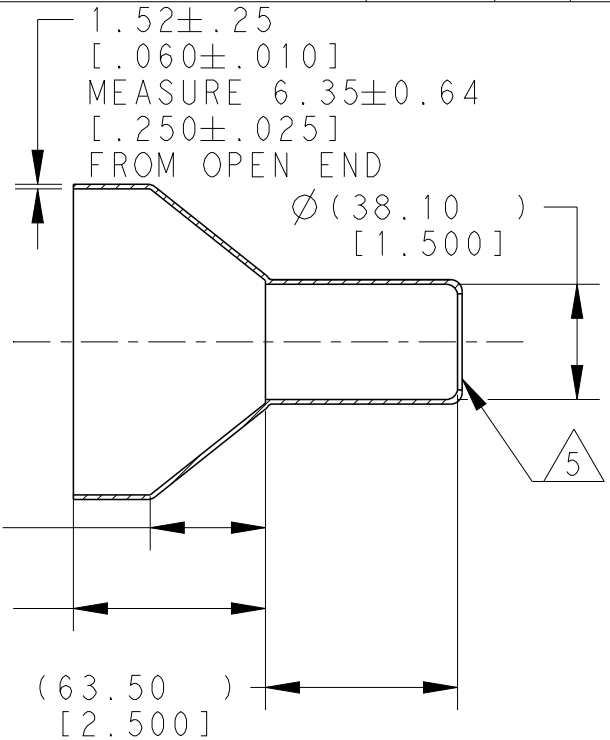
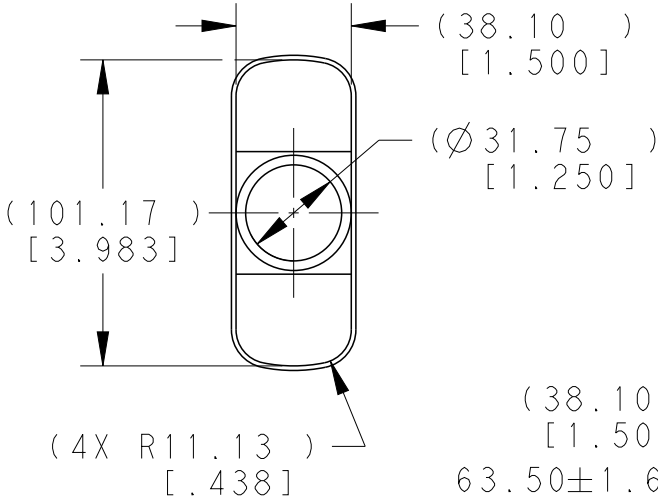

6. SMALL NON-FILLS ARE ACCEPTABLE INSIDE OF PART, INCLUDING SUPPLIER MARKING.
5. SMALL MATERIAL EXTENSION IS ACCEPTABLE ON THIS END ALL AROUND. WALL THICKNESS ON THIS END MAY VARY.
4. BOTTOM OF PART MOLDED OPEN.
3. THIS ACCESSORY PART IS PROVIDED WITHOUT TYPICAL TRANSPORTATION INDUSTRY PROCESS CONTROLS. NO VALIDATION TESTING HAS BEEN PERFORMED. CUSTOMER IS RESPONSIBLE FOR DETERMINING PRODUCT PERFORMANCE AND SUITABILITY FOR APPLICATION.
2. TEMPERATURE RATING: -29°C TO +100°C [-20°F TO +212°F]
1. THIS PART IS USED ON  
 DRC12-70PX(E)-XXXX RECEPTACLES  
 DRC14-70PX(E)-XXXX RECEPTACLES  
 DRC16-70SX(E)-XXXX PLUG  
 WHERE X=A,B,C,D KEYS AND XXXX=MODIFICATIONS

NOTES:

TE INTERNAL PN	DEUTSCH PN
DRC70-BT	DRC70-BT

2014

RELEASED FOR PUBLICATION

THIS DRAWING IS UNPUBLISHED.

ALL RIGHTS RESERVED.

BY TE CONNECTIVITY

© COPYRIGHT 2014

DIMENSIONS: mm [ INCHES ]	DWN D.MEYER	07JUL2014	MATERIAL PVC	FINISH BLACK
	CHK D.HASIBUAN	07JUL2014	TE Connectivity	
TOLERANCES UNLESS OTHERWISE SPECIFIED:	APVD D.MEYER	07JUL2014		
	0 PLC ±-	PRODUCT SPEC	SIZE A4	CAGE CODE 44AFU8
1 PLC ±-	APPLICATION SPEC	RESTRICTED TO		
2 PLC ±0.63 [.025]	WEIGHT 68.00 G			
3 PLC ±-	CUSTOMER DRAWING	SCALE 2:5	SHEET 1 OF 1	REV A3
4 PLC ±-				
ANGLES ±5°				

