

THIS DRAWING IS UNPUBLISHED. RELEASED FOR PUBLICATION - N/A .  
 © COPYRIGHT N/A BY TYCO ELECTRONICS CORPORATION. ALL RIGHTS RESERVED.

LOC	DIST	REVISIONS					
		P	LTR	DESCRIPTION	DATE	DWN	APVD
DF	S0	AC		REV PER ECO-05-002357	08-05	AA	DE

PART NO.	A <sup>1</sup>	B	C	D	REMARKS
848076-1	24.00 [609.6]	6.00 [152.4]	-	2.50 [63.5]	<sup>5</sup> OBSOLETE
848076-2	14.50 [368.3]	12.00 [304.8]	12.00 [304.8]	2.50 [63.5]	<sup>5</sup> OBSOLETE
848076-3	48.00 [1219.2]	6.00 [152.4]	-	2.50 [63.5]	<sup>5</sup> OBSOLETE
848076-4	144.00 [3657.6]	6.00 [152.4]	-	2.50 [63.5]	<sup>5</sup> OBSOLETE
848076-5	18.00 [457.2]	6.00 [152.4]	-	2.50 [63.5]	<sup>5</sup> OBSOLETE
848076-6	14.00 [355.6]	7.00 [177.8]	7.00 [177.8]	2.50 [63.5]	<sup>5</sup> OBSOLETE
848076-7	48.00 [1219.2]	7.00 [177.8]	7.00 [177.8]	2.50 [63.5]	<sup>5</sup> OBSOLETE
848076-8	36.00 [914.4]	7.00 [177.8]	7.00 [177.8]	2.50 [63.5]	<sup>5</sup> OBSOLETE
848076-9	72.00 [1828.8]	6.00 [152.4]	-	2.50 [63.5]	<sup>5</sup> OBSOLETE
1-848076-0	84.00 [2133.6]	6.00 [152.4]	-	2.50 [63.5]	<sup>5</sup> OBSOLETE
1-848076-1	12.00 [304.8]	6.00 [152.4]	-	2.50 [63.5]	<sup>5</sup> OBSOLETE
1-848076-2	300.00 [7620.0]	6.00 [152.4]	-	2.50 [63.5]	<sup>5</sup> OBSOLETE
1-848076-3	240.00 [6096.0]	6.00 [152.4]	-	2.50 [63.5]	<sup>5</sup> OBSOLETE
1-848076-4	60.00 [1524.0]	6.00 [152.4]	-	2.50 [63.5]	<sup>5</sup> OBSOLETE
1-848076-5	180.00 [4572.0]	6.00 [152.4]	-	2.50 [63.5]	<sup>5</sup> OBSOLETE
1-848076-6	120.00 [3048.0]	6.00 [152.4]	-	2.50 [63.5]	<sup>5</sup> OBSOLETE
1-848076-7	96.00 [2438.4]	6.00 [152.4]	-	2.50 [63.5]	<sup>5</sup> OBSOLETE
1-848076-8	75.00 [1905.0]	6.00 [152.4]	-	2.50 [63.5]	<sup>5</sup> OBSOLETE
1-848076-9	252.00 [6400.8]	6.00 [152.4]	-	2.50 [63.5]	<sup>5</sup> OBSOLETE
2-848076-0	300.00 [7620.0]	6.00 [152.4]	6.00 [152.4]	2.50 [63.5]	<sup>5</sup> OBSOLETE
2-848076-1	360.00 [9144.0]	6.00 [152.4]	12.00 [304.8]	2.50 [63.5]	<sup>5</sup> OBSOLETE
2-848076-2	16.25 [412.8]	-	6.00 [152.4]	6.00 [152.4]	<sup>5</sup> OBSOLETE
2-848076-3	29.75 [755.7]	-	6.00 [152.4]	6.00 [152.4]	<sup>5</sup> OBSOLETE
2-848076-4	20.25 [514.4]	-	6.00 [152.4]	9.00 [228.6]	<sup>5</sup> OBSOLETE
2-848076-5	21.75 [552.5]	-	6.00 [152.4]	6.00 [152.4]	<sup>5</sup> OBSOLETE
2-848076-6	16.25 [412.8]	-	6.00 [152.4]	7.00 [177.8]	<sup>5</sup> OBSOLETE
2-848076-7	21.00 [533.4]	-	6.00 [152.4]	8.00 [203.2]	<sup>5</sup> OBSOLETE
5-848076-3	48.00 [1219.2]	6.00 [152.4]	-	2.50 [63.5]	<sup>6</sup> OBSOLETE
7-848076-2	16.25 [412.8]	-	6.00 [152.4]	6.00 [152.4]	<sup>6</sup> OBSOLETE
7-848076-3	29.75 [755.7]	-	6.00 [152.4]	6.00 [152.4]	<sup>6</sup> OBSOLETE
7-848076-5	21.75 [552.5]	-	6.00 [152.4]	6.00 [152.4]	<sup>6</sup> OBSOLETE
7-848076-6	16.25 [412.8]	-	6.00 [152.4]	7.00 [177.8]	<sup>6</sup> OBSOLETE

- <sup>1</sup> TOLERANCE OF LEAD LENGTH:  
UP TO 24 INCHES [609.6] = ±.12 [±3.0]  
24 INCHES [609.6] & UP = ±1%
- 2. MARKED WITH BLACK INK PER MIL-STD-130.
- 3. TO MATE WITH AMP LGH-3  
RECEPTACLE WITH 1.81 [45.9] BARREL DEPTH.
- 4. OPERATING VOLTAGE: 40 KVDC AT 0 TO 70,000 FEET,  
-55°C TO 125°C.
- <sup>5</sup> PIGTAIL IS SOLDER DIPPED.
- <sup>6</sup> INSULATION CUT, BUT NOT REMOVED.

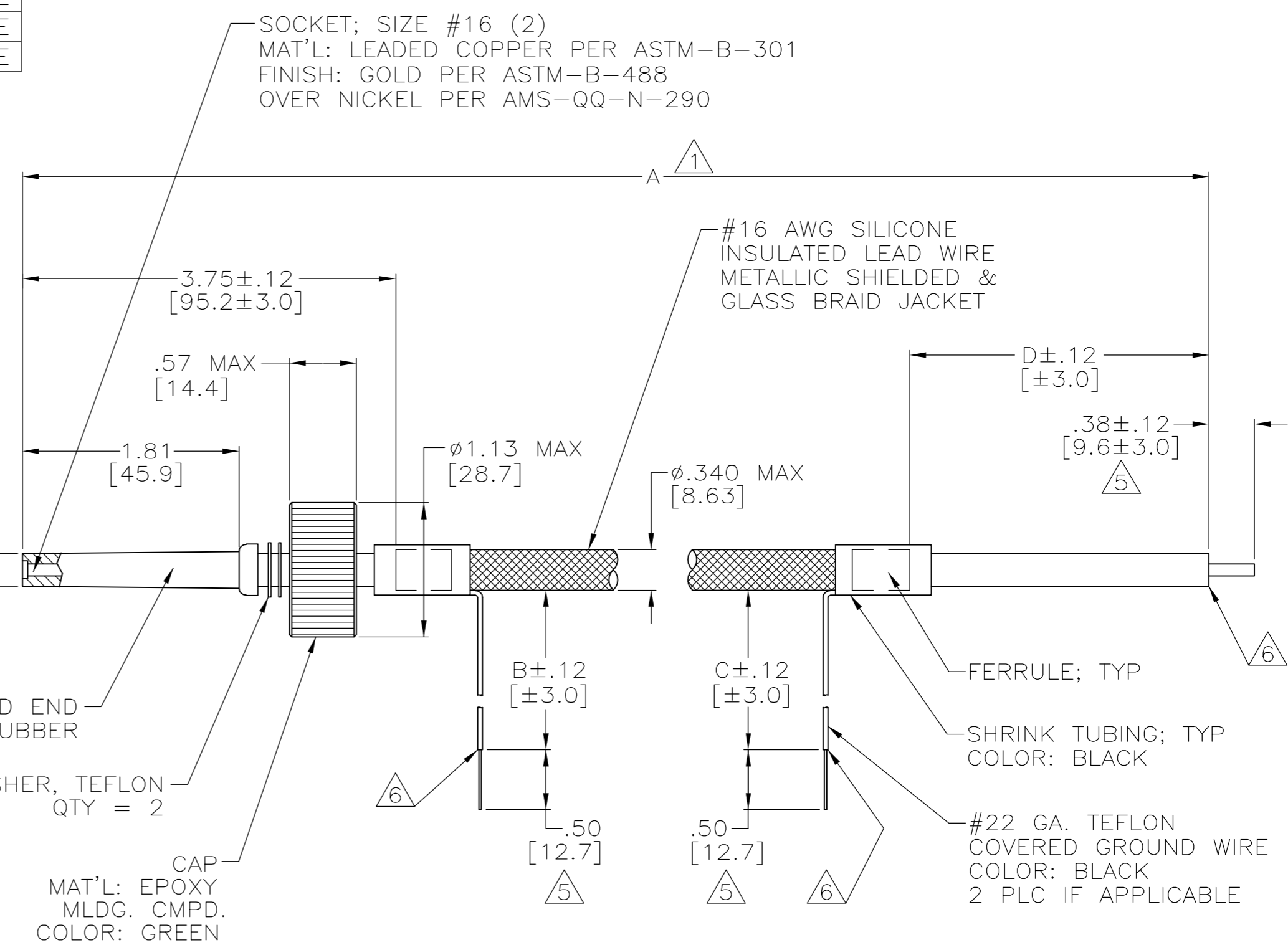

THIS DRAWING IS A CONTROLLED DOCUMENT.		DWN C.C.THOMAS 27-MAR-90	<b>tyco</b> Electronics	Tyco Electronics Corporation Harrisburg, Pa 17105-3608	
DIMENSIONS: INCHES [mm]		CHK D.OPPLINGER 09-APR-90		NAME LEAD ASSY, SGL END SHIELDED & GLASS BRAID COVERED LGH-3	
TOLERANCES UNLESS OTHERWISE SPECIFIED:		APVD D.OPPLINGER 09-APR-90	PRODUCT SPEC		
0 PLC ± -		APPLICATION SPEC			
1 PLC ± -		WEIGHT -			
2 PLC ± .02 [0.5]		SCALE 1:1			
3 PLC ± -		SHEET 1 OF 1			
4 PLC ± -		REV AC			
ANGLES ± -		CUSTOMER DRAWING			
FINISH SEE CALLOUTS		SIZE A2 CAGE CODE 00779 C=848076			