

RECOMMENDED PCB LAYOUT
COMPONENT SIDE

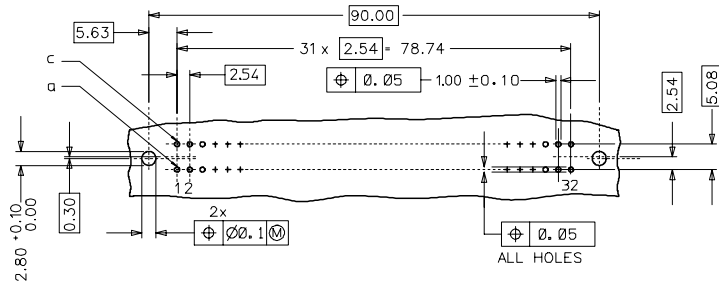

WITH MOUNTING CLIPS

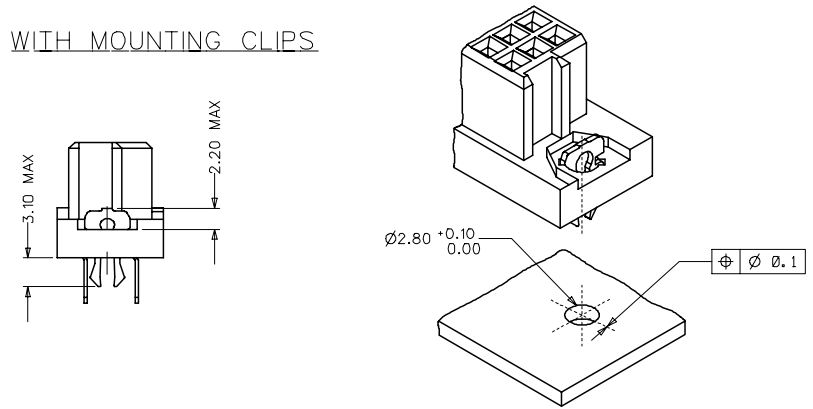

NOTES:

- 1) MATERIALS: THERMOPLASTIC POLYESTER, GLASS FILLED, UL94V-0. COLOUR: PEBBLE GREY RAL 7032
TERMINAL - PHOSPHOR BRONZE
MOUNTING CLIP: STEEL
- 2) FINISH: TERMINAL:-
CONTACT AREA
1. PERFORMANCE LEVEL 1: SELECTIVE GOLD (Au), THICKNESS - 1.1 MICROMETER
OVER NICKEL, THICKNESS - 1.5 MICROMETER
2. PERFORMANCE LEVEL 2: SELECTIVE GOLD (Au), THICKNESS - 0.6 MICROMETER
OVER NICKEL, THICKNESS - 1.5 MICROMETER
3. PERFORMANCE LEVEL 3: SELECTIVE GOLD (Au), THICKNESS - 0.3 MICROMETER
OVER NICKEL, THICKNESS - 1.5 MICROMETER
TERMINATION AREA:
SELECTIVE TIN, THICKNESS - 5 MICROMETER
OVER NICKEL, THICKNESS - 1.5 MICROMETER OVERALL
- 3) MOUNTING CLIP:-
TIN (Sn), THICKNESS - 5-10 MICROMETER,
OVER NICKEL (Ni), THICKNESS - 2.5 MICROMETER
- 4) FOR NON MOUNTING CLIP OPTION, CONNECTOR TO BE SECURED WITH
RIVETS: 2 TUBULAR RIVETS 2.5 x 0.3 ... DIN 7340
SCREWS: 2 CHEESEHEAD SCREWS M2.5 x ... DIN 84 AND 2 HEXAGONAL NUTS M2.5 DIN 934
- 5) MATERIAL No, BATCH CODE, UL AND CSA MARKING TO BE PRINTED ON THE CONNECTOR.
- 6) CUT FACES OF TIP WITHOUT PLATING PERMITTED.
- 7) PRODUCT SPECIFICATION PS:36500-001

RoHS COMPLIANT

ENTER DESCRIPTION E.C.N.C.12007.0044 DRAWING APPROVED 2006/10/10 CHKD:SSUDHIR 2006/10/11 APPROVED:SSUDHIR 2006/10/16	QUALITY SYMBOLS ▽=0 ▽=0	GENERAL TOLERANCES (UNLESS SPECIFIED)		DIMENSION STYLE MM ONLY		SCALE 2:1	DESIGN UNITS METRIC	THIRD ANGLE PROJECTION
		4 PLACES ±	mm	INCH	DRAWN BY SHANKAR	DATE 2006/03/29	TITLE ASSEMBLY DIN 41612 64POS C FEMALE A+C LOADED 1.0MM PCB DIA	
C1	DESCRIPTION	3 PLACES ± 0.05	±	±	CHECKED BY SSUDHIR	DATE 2006/03/29	MOLEX INCORPORATED	
		2 PLACES ± 0.1	±	±	APPROVED BY SSUDHIR	DATE 2006/03/29	MATERIAL NO. SD-36500-003	DOCUMENT NO. SD-36500-003
DRAFT WHERE APPLICABLE MUST REMAIN WITHIN DIMENSIONS		ANGULAR ± 2°		SEE SHEET 2		SHEET NO. 1 OF 2		
THIS DRAWING CONTAINS INFORMATION THAT IS PROPRIETARY TO MOLEX INCORPORATED AND SHOULD NOT BE USED WITHOUT WRITTEN PERMISSION								

	20	19	18	17	16	15	14	13	12	11	10	9	8	7	6	5	4	3	2	1
	MATERIAL No	MOLEX ENG No	PERF LEVEL	PLATING	CONTACT SEQUENCE/ROW	DIM "L" mm	MOUNTING CLIP	FLUX PROOF												
	36500-0097	MM-B2401-C963	1	Au+Ni	1.2.3....32 a+c	2.9	NO	NO												
	36500-0098	MM-B2501-C963	2	Au+Ni	1.2.3....32 a+c	2.9	NO	NO												
	36500-0099	MM-B2601-C963	3	Au+Ni	1.2.3....32 a+c	2.9	NO	NO												
L	36500-0103	MM-B2401-C913	1	Au+Ni	1.2.3....32 a+c	2.9	YES	NO												
	36500-0104	MM-B2501-C913	2	Au+Ni	1.2.3....32 a+c	2.9	YES	NO												
	36500-0105	MM-B2601-C913	3	Au+Ni	1.2.3....32 a+c	2.9	YES	NO												
	36500-0109	MM-B2401-C963-133	1	Au+Ni	1.2.3....32 a+c	2.9	NO	YES												
	36500-0110	MM-B2501-C963-133	2	Au+Ni	1.2.3....32 a+c	2.9	NO	YES												
K	36500-0111	MM-B2601-C963-133	3	Au+Ni	1.2.3....32 a+c	2.9	NO	YES												
	36500-0115	MM-B2401-C913-133	1	Au+Ni	1.2.3....32 a+c	2.9	YES	YES												
	36500-0116	MM-B2501-C913-133	2	Au+Ni	1.2.3....32 a+c	2.9	YES	YES												
	36500-0117	MM-B2601-C913-133	3	Au+Ni	1.2.3....32 a+c	2.9	YES	YES												
J	36500-0121	MM-B2402-C963	1	Au+Ni	1.2.3....32 a+c	4.5	NO	NO												
	36500-0122	MM-B2502-C963	2	Au+Ni	1.2.3....32 a+c	4.5	NO	NO												
	36500-0123	MM-B2602-C963	3	Au+Ni	1.2.3....32 a+c	4.5	NO	NO												
	36500-0127	MM-B2402-C913	1	Au+Ni	1.2.3....32 a+c	4.5	YES	NO												
	36500-0128	MM-B2502-C913	2	Au+Ni	1.2.3....32 a+c	4.5	YES	NO												
I	36500-0129	MM-B2602-C913	3	Au+Ni	1.2.3....32 a+c	4.5	YES	NO												
	36500-0133	MM-B2402-C963-133	1	Au+Ni	1.2.3....32 a+c	4.5	NO	YES												
	36500-0134	MM-B2502-C963-133	2	Au+Ni	1.2.3....32 a+c	4.5	NO	YES												
	36500-0135	MM-B2602-C963-133	3	Au+Ni	1.2.3....32 a+c	4.5	NO	YES												
H	36500-0139	MM-B2402-C913-133	1	Au+Ni	1.2.3....32 a+c	4.5	YES	YES												
	36500-0140	MM-B2502-C913-133	2	Au+Ni	1.2.3....32 a+c	4.5	YES	YES												
	36500-0141	MM-B2602-C913-133	3	Au+Ni	1.2.3....32 a+c	4.5	YES	YES												

RoHS COMPLIANT

ENTER DESCRIPTION ELC.NCL.12007.0044. 2006/10/10 DRWNGSATTI/MARAD 2006/10/10 CHKD/SSUDHIR 2006/10/11 APPR/SSUDHIR 2006/10/16	QUALITY SYMBOLS 	GENERAL TOLERANCES (UNLESS SPECIFIED)		DIMENSION STYLE MM ONLY		SCALE ---	DESIGN UNITS METRIC	THIRD ANGLE PROJECTION	
		4 PLACES ±---± 3 PLACES ±---± 2 PLACES ±---± 1 PLACE ±---±	mm INCH	DRAWN BY SHANKAR	DATE 2006/03/29	TITLE ASSEMBLY DIN 41612 64POS C FEMALE A+C LOADED 1.0MM PCB DIA			
		ANGULAR ±---°		CHECKED BY SSUDHIR	DATE 2006/03/29	MOLEX INCORPORATED			
		DRAFT WHERE APPLICABLE MUST REMAIN WITHIN DIMENSIONS		APPROVED BY SSUDHIR	DATE 2006/03/29	MATERIAL NO. SEE CHART	DOCUMENT NO. SD-36500-003	SHEET NO. 2 OF 2	THIS DRAWING CONTAINS INFORMATION THAT IS PROPRIETARY TO MOLEX INCORPORATED AND SHOULD NOT BE USED WITHOUT WRITTEN PERMISSION