

PART NUMBER	REVISION	DESCRIPTION	FEED TYPE
2266018-1	C	FINE CRIMP HEIGHT ADJUST	MECHANICAL
2266018-2	C	FINE CRIMP HEIGHT ADJUST	PNEUMATIC
7-2266018-1	C	MECHANICAL AND CRIMP TOOLING KIT	MECHANICAL
7-2266018-2	C	PNEUMATIC AND CRIMP TOOLING KIT	PNEUMATIC
7-2266018-7	A	CRIMP TOOLING KIT	-

ATLANTIC VERSION TERMINATOR INTERFACE ADAPTER

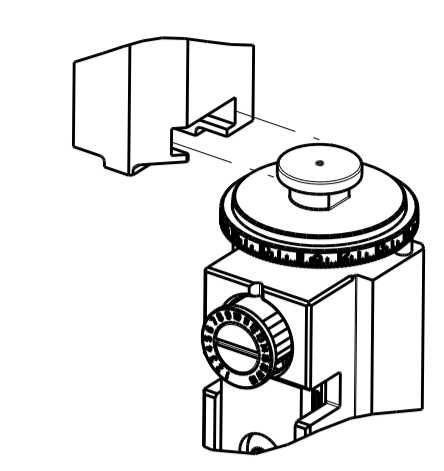

APPLICATOR DATA		
CRIMP	SIZE	TYPE
WIRE	3.30 mm [.130]	F
INSUL	3.30 mm [.130]	O

APPLICATOR INSTRUCTIONS
408-35042

TERMINAL DATA: TE TERMINAL		TE CRIMP SPECIFICATION	
TERMINAL NAME: RING TONGUE M4			
WIRE STRIP LENGTH		INSULATION DIAMETER RANGE	
4.30-5.10 mm [.169-.201 IN]		Ø1.55-2.10 mm [.061-.083 IN]	
TERMINAL APPLICATION SPECIFICATION	114-18022		
TERMINALS APPLIED			
TE TERMINAL	TE TERMINAL	TE TERMINAL	TE TERMINAL
1-1670969-1	1-1670969-2		

WIRE SIZE	CRIMP HEIGHT mm [INCH]	CRIMP HEIGHT REFERENCE SETTING
1.00mm2	2.24 +/- 0.05 [.088 +/- .002]	7.1
0.75mm2	2.18 +/- 0.05 [.086 +/- .002]	7.7

- 1. RECOMMENDED SPARE PARTS
- 2. REFER TO SUPPLIED INSTRUCTION SHEET FOR CLEANING, LUBRICATION AND STORAGE OF APPLICATOR.
- 3. APPLY PART NUMBER 2-23419-6 LOCTITE TO THREADS OF ITEM 242.
- 4. CRIMP HEIGHT REFERENCE SETTING WAS THE SETTING USED WHEN THE APPLICATOR WAS QUALIFIED AT THE FACTORY. ADJUSTMENT MAY BE NECESSARY WHEN RUNNING APPLICATOR IN THE FIELD.
- 5. UNLESS SPECIFIED OTHERWISE TORQUE VALUES SHALL BE USED PER DOCUMENT, 101-35000.

***WARNING**
ON INSTALLATION, SET WIRE DISC TO CRIMP HEIGHT REFERENCE SETTING FOR LARGEST WIRE SIZE. CRIMP HEIGHT REFERENCE SETTINGS GREATER THAN THE VALUE SHOWN MAY CAUSE DAMAGE TO THE CRIMP TOOLING, REFER TO THE INSTRUCTION SHEET FOR PROPER SETUP AND ADJUSTMENTS.

ATLANTIC VERSION
Shown on sheets 1 of 4 & 2 of 4
(Pacific version shown on sheets 3 of 4 & 4 of 4)

LOC	DIST	REVISIONS					
A	66	P	LTN	DESCRIPTION	DATE	OWN	APVD
		B		ECR-15-008732	09JUN2015	MR	JDG
		C		ECR-19-003186	28FEB2019	FZ	YY

-	1	-	1	-	2119640-1	PUSH ROD, AIR FEED	250	
-	1	-	1	-	1803259-1	BUSHING, FLANGED	249	
-	1	-	1	-	2119641-1	FEED CAM, AIR FEED	248	
-	1	1	1	1	2119082-9	CAM, SNAIL, INSULATION ADJUSTMENT	244	
-	1	1	1	1	2079764-1	WASHER, WAVE SPRING, CREST-TO-CREST	243	
-	1	1	1	1	2119083-1	RETAINER, INSULATION DIAL	242	
-	1	1	1	1	7-18023-7	SCR, SKT HD CAP M3 X 4.0	241	
-	-	1	-	1	2119580-1	MECHANICAL FEED ASSEMBLY	239	
-	1	-	1	-	2063440-1	AIR FEED MODULE	238	
-	2	-	2	-	21045-3	RING, RETAIN, EXTERN, 3/16 CRESCENT	172	
-	REF	REF	REF	REF	994970-2	COUNTER, MAGNETIC	164	
-	1	-	1	-	240638-1	SPRING, FEED FINGER	163	
-	1	-	1	-	3-23627-7	PIN, RETAIN, GRVD, 3/16 X .854	137	
-	1	-	1	-	2119799-1	HOLDER, FEED FINGER, AF	136	
-	1	1	1	1	1-18028-2	WASHER, FLAT, REG M4	119	
-	1	1	1	1	2844908-1	SCREW, LOCKING	99	
-	1	1	1	1	2844907-1	POST, LOCKING	98	
-	1	1	1	1	455888-4	SPACER, CRIMPER	82	
-	1	1	1	1	1803607-1	DOCUMENTATION PACKAGE	71	
-	1	1	1	1	2119740-1	TAG, IDENTIFICATION	67	
-	2	2	2	2	2168078-1	SCREW, DRIVE, RH, RoHS, 2 x .188	66	
-	1	1	1	1	2168083-2	SCR, SKT HD CAP, RoHS, M4 X 8.0	60	
-	1	1	1	1	5-18022-5	SCR, HEX HD CAP, M4 X 6.0	59	
-	1	1	1	1	1338685-1	PAWL, FEED	56	
-	4	4	4	4	2168083-3	SCR, SKT HD CAP, RoHS, M4 X 12.0	54	
-	2	2	2	2	2-2168083-5	SCR, SKT HD CAP, RoHS, M4 X 14	53	
-	1	1	1	1	5018030-1	NUT, HEX, REG, RoHS, M3	52	
-	1	1	1	1	811242-5	BUMPER, HOLD DOWN	51	
-	1	1	1	1	690753-2	SPACER, TONKER	50	
-	1	2	1	2	18023-9	SCR, SKT HD CAP M4 X 6.0	49	
-	-	1	-	1	2119652-1	FEED CAM, PRE FEED	48	
-	-	1	-	1	2119653-1	FEED CAM, POST FEED	47	
-	1	1	1	1	1803583-9	APPLICATOR BASIC ASSEMBLY, SF	46	
-	1	1	1	1	1803515-1	RAM ASSEMBLY, SF ATLANTIC	44	
-	1	1	1	1	1803602-1	SCR, BHSC, RoHS (M8 X 25)	41	
-	1	1	1	1	1752356-1	SUPPORT, TERMINAL	34	
-	2	2	2	2	2079383-5	SCR, BHSC, RoHS (M4 X 20)	33	
-	2	2	2	2	3-2844962-2	SPACER, CYLINDRICAL, STRIP GUIDE	30	
-	1	1	1	1	2844992-4	ASSEMBLY, STRIP GUIDE	29	
-	1	1	1	1	1-455888-0	SPACER, CRIMPER	28	
-	1	1	1	1	240792-1	DRAG, TERMINAL	25	
-	1	1	1	1	1320928-2	STRIP GUIDE	24	
-	1	1	1	1	2168083-2	SCR, SKT HD CAP, RoHS, M4 X 8.0	21	
-	1	1	1	1	1-18028-2	WASHER, FLAT, REG M4	20	
-	1	1	1	1	2119533-1	STRIPPER, SIDE FEED	19	
-	1	1	1	1	2119806-1	INSERT, SHEAR	13	
-	1	1	1	1	3-22280-3	SPRING, COMPRESSION	12	
-	1	1	1	1	1-356885-3	STOP, SHEAR	11	
-	1	1	1	1	2119805-1	SHEAR HOLDER, FRONT	10	
-	1	1	1	1	454276-5	FLOATING SHEAR, FRONT	9	
-	1	2	2	1	1	5-1633139-6	ANVIL, COMBINATION	8
-	1	1	1	1	240641-5	SPACER	7	
-	-	-	-	-	-	-	6	
-	1	1	1	1	2119757-8	DEPRESSOR, SHEAR	5	
-	1	1	1	1	4-238011-5	BLOCK, CRIMPER SPACER	4	
-	1	2	2	1	1	3-1803018-1	CRIMPER, INSULATION O	3
-	1	1	1	1	455888-6	SPACER, CRIMPER	2	
-	1	2	2	1	1	3-456410-7	CRIMPER, WIRE PREMIUM	1
-	77	-72	-71	-2	-1	PART NO	DESCRIPTION	ITEM NO

DIMENSIONS:		TOLERANCES UNLESS OTHERWISE SPECIFIED:		OWN	15AUG2013	TE Connectivity	
mm	0 PLC ±	1 PLC ±	2 PLC ±	CHK	15AUG2013	Harrisburg, PA 17105-3608	
	3 PLC ±	4 PLC ±	ANGLES ±	APVD	15AUG2013	NAME	
	FINISH					Ocean Side Feed Applicator	
MATERIAL		WEIGHT		SIZE	CAGE CODE	DRAWING NO	RESTRICTED TO
				A1	00779	2266018	
Customer Accessible Production Drawing				SCALE	1:2	SHEET	1 OF 4
				REV	C		

LOC		DIST		REVISIONS			
REV	DATE	BY	CHK	DESCRIPTION	DATE	DWN	APVD
A	66			SEE SHEET 1			

FEED TYPE MECHANICAL



PNEUMATIC

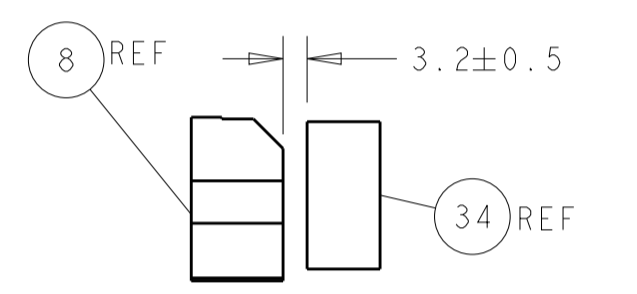
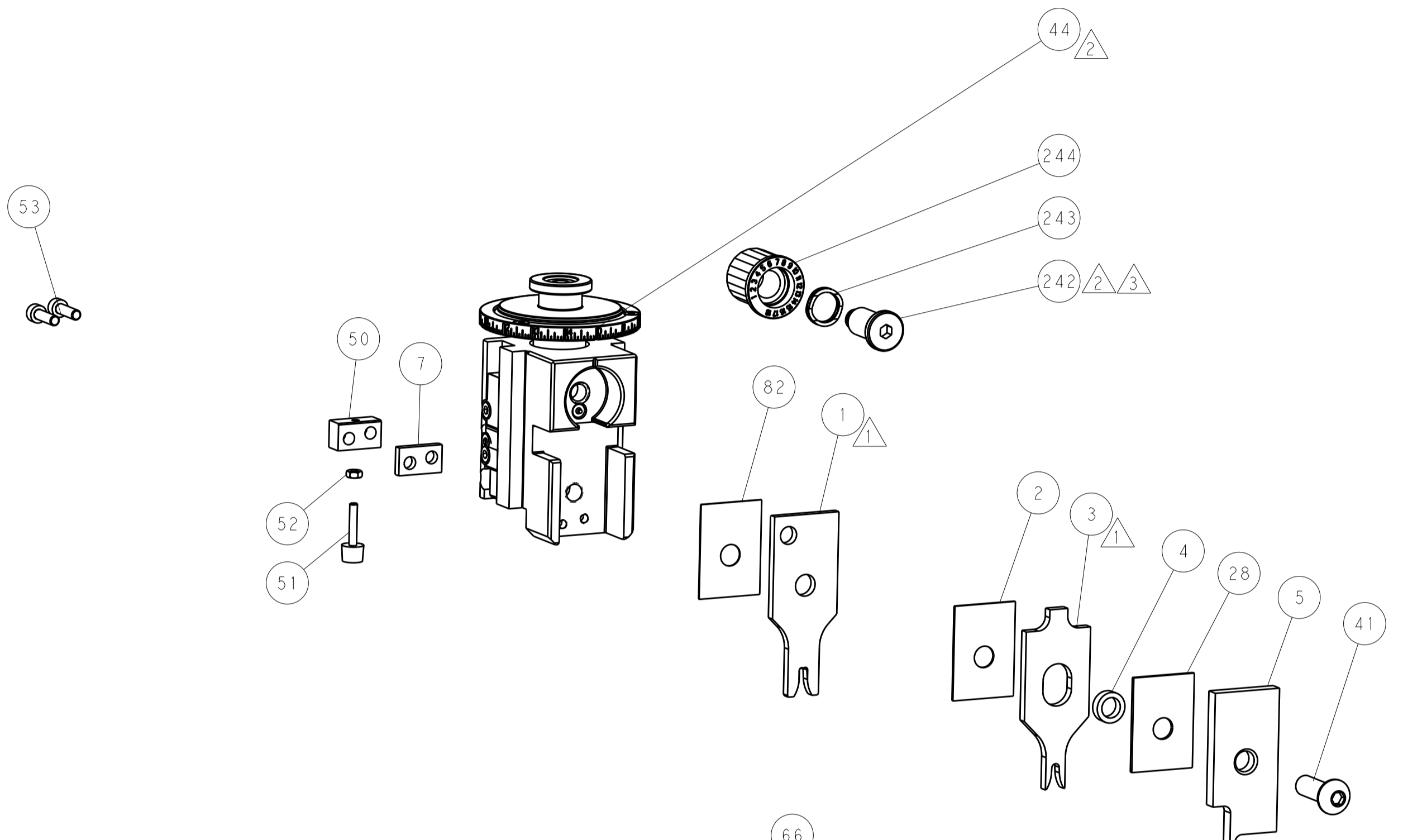
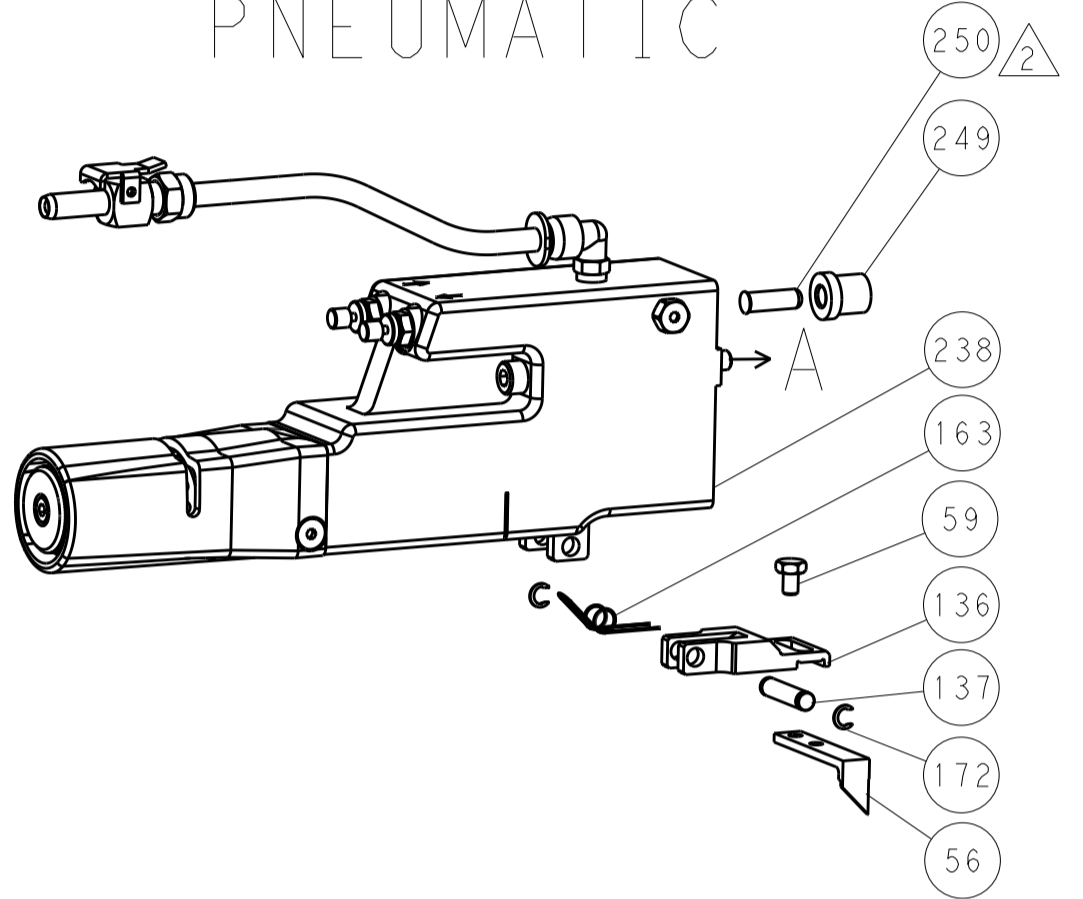

TERMINAL SUPPORT LOCATION

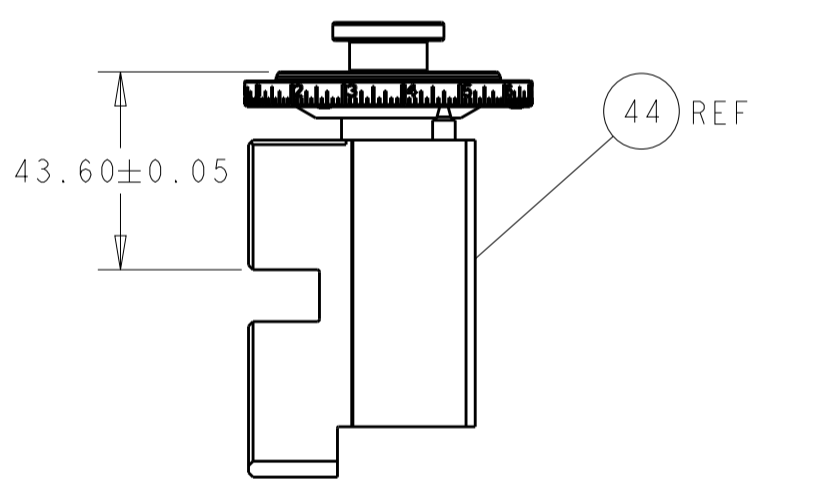

RAM SET-UP

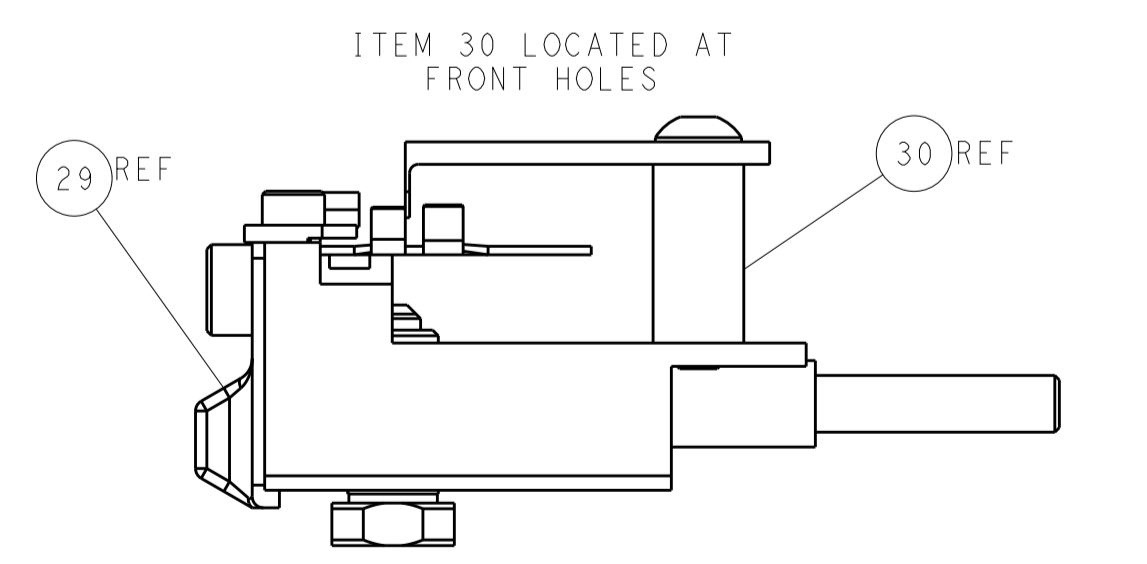

FEED TRACK POSITION GUIDE BY INSULATION BARREL

CAM POSITIONS

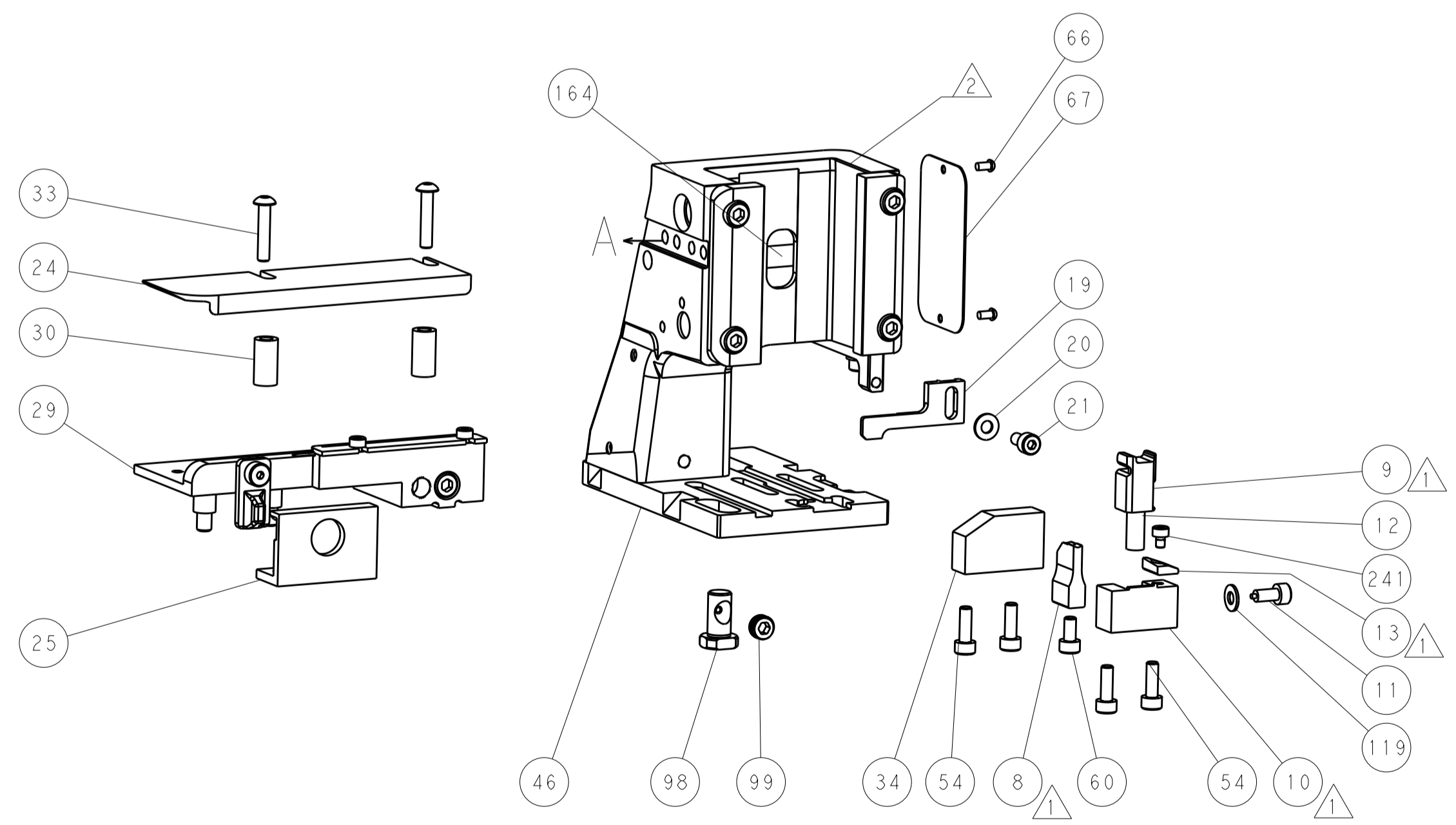
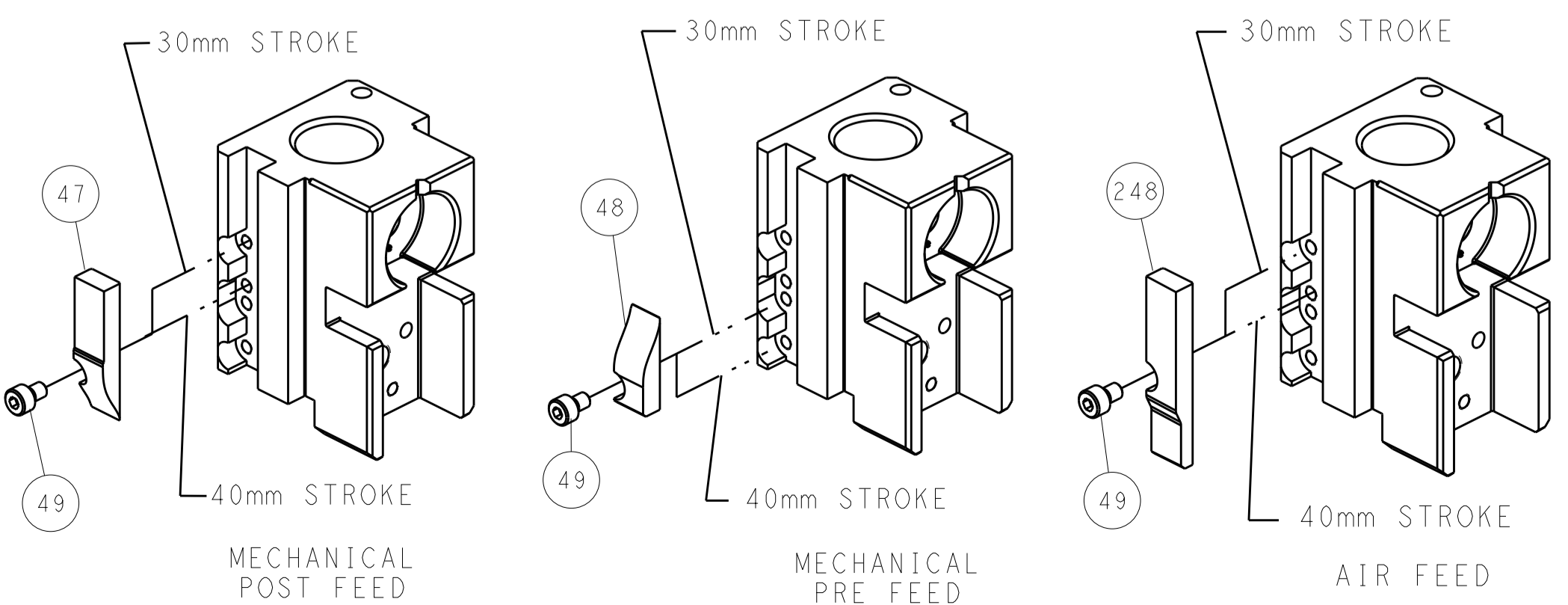

ATLANTIC VERSION
 Shown on sheets 1 of 4 & 2 of 4
 (Pacific version shown on sheets 3 of 4 & 4 of 4)

DIMENSIONS:		TOLERANCES UNLESS OTHERWISE SPECIFIED:		DWN: C. CHEN 15AUG2013		TE Connectivity	
mm	0 PLC ±	1 PLC ±	2 PLC ±	3 PLC ±	4 PLC ±	5 PLC ±	Harrisburg, PA 17105-3608
MATERIAL:		FINISH:		CHK: U. GUO 15AUG2013		NAME: Ocean Side Feed Applicator	
				APVD: J. CRUZ 15AUG2013		SIZE: CAGE CODE: DRAWING NO: RESTRICTED TO	
				PRODUCT SPEC:		A1 00779 ©=2266018	
				APPLICATION SPEC:		Customer Accessible Production Drawing	
				WEIGHT:		SCALE: 1:2 SHEET 2 OF 4 REV C	

PART NUMBER	REVISION	DESCRIPTION	FEED TYPE
2-2266018-1	C	FINE CRIMP HEIGHT ADJUST	MECHANICAL
2-2266018-2	C	FINE CRIMP HEIGHT ADJUST	PNEUMATIC
7-2266018-7	A	CRIMP TOOLING KIT	-

PACIFIC VERSION TERMINATOR
 INTERFACE ADAPTER

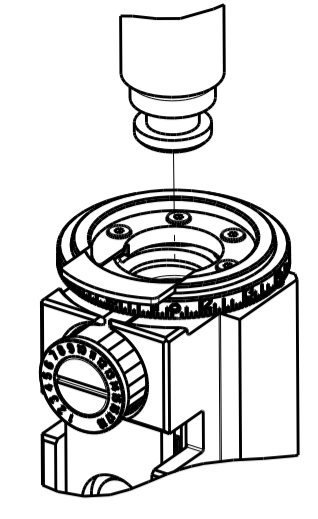

APPLICATOR DATA		
CRIMP	SIZE	TYPE
WIRE	3.30 mm [.130]	F
INSUL	3.30 mm [.130]	O

APPLICATOR INSTRUCTIONS
 408-35042

TERMINAL DATA: TE TERMINAL		TE CRIMP SPECIFICATION	
TERMINAL NAME: RING TONGUE M4			
WIRE STRIP LENGTH 4.30-5.10 mm [1.69-.201 IN]		INSULATION DIAMETER RANGE Ø1.55-2.10 mm [1.061-.083 IN]	
TERMINAL APPLICATION SPECIFICATION 114-18022			
TERMINALS APPLIED			
TE TERMINAL	TE TERMINAL	TE TERMINAL	TE TERMINAL
1-1670969-1	1-1670969-2		

WIRE SIZE	CRIMP HEIGHT mm [INCH]	CRIMP HEIGHT REFERENCE SETTING
1.00mm2	2.24+/-0.05 [1.088+/-0.002]	7.1
0.75mm2	2.18+/-0.05 [1.086+/-0.002]	7.7



- 1 RECOMMENDED SPARE PARTS
- 2 REFER TO SUPPLIED INSTRUCTION SHEET FOR CLEANING, LUBRICATION AND STORAGE OF APPLICATOR.
- 3 APPLY PART NUMBER 2-23419-6 LOCTITE TO THREADS OF ITEM 242.
- 4 CRIMP HEIGHT REFERENCE SETTING WAS THE SETTING USED WHEN THE APPLICATOR WAS QUALIFIED AT THE FACTORY. ADJUSTMENT MAY BE NECESSARY WHEN RUNNING APPLICATOR IN THE FIELD.
- 5. UNLESS SPECIFIED OTHERWISE TORQUE VALUES SHALL BE USED PER DOCUMENT, 101-35000.

***WARNING**
 ON INSTALLATION, SET WIRE DISC TO CRIMP HEIGHT REFERENCE SETTING FOR LARGEST WIRE SIZE. CRIMP HEIGHT REFERENCE SETTINGS GREATER THAN THE VALUE SHOWN MAY CAUSE DAMAGE TO THE CRIMP TOOLING, REFER TO THE INSTRUCTION SHEET FOR PROPER SETUP AND ADJUSTMENTS.

PACIFIC VERSION
 Shown on sheets 3 of 4 & 4 of 4
 (Atlantic version shown on sheets 1 of 4 & 2 of 4)

LOC	DIST	REVISIONS					
A	66	P	LTN	DESCRIPTION	DATE	OWN	APVD
		-	-	SEE SHEET 1			

-	1	-	2119640-1	PUSH ROD, AIR FEED	250	
-	1	-	1803259-1	BUSHING, FLANGED	249	
-	1	1	2119082-9	CAM, SNAIL, INSULATION ADJUSTMENT	244	
-	1	1	2079764-1	WASHER, WAVE SPRING, CREST-TO-CREST	243	
3	-	1	1	2119083-1	RETAINER, INSULATION DIAL	242
-	1	1	7-18023-7	SCR, SKT HD CAP M3 X 4.0	241	
-	-	1	2119580-1	MECHANICAL FEED ASSEMBLY	239	
-	1	-	2063440-1	AIR FEED MODULE	238	
-	2	-	21045-3	RING, RETAIN, EXTERN, 3/16 CRESCENT	172	
-	REF	REF	994970-2	COUNTER, MAGNETIC	164	
-	1	-	240638-1	SPRING, FEED FINGER	163	
-	1	-	2119641-2	FEED CAM, AIR FEED	151	
-	1	1	2168083-8	SCR, SKT HD CAP, RoHS, M4 X 16	144	
-	4	4	2168083-9	SCR, SKT HD CAP, RoHS, M4 X 20	143	
-	-	1	2119653-2	FEED CAM, POST FEED	142	
-	1	1	1-1803583-0	APPLICATOR BASIC ASSEMBLY, SF	141	
-	1	1	1803516-1	RAM ASSEMBLY, SF PACIFIC	140	
-	1	-	3-23627-7	PIN, RETAIN, GRVD, 3/16 X .854	137	
-	1	-	2119799-1	HOLDER, FEED FINGER, AF	136	
-	1	1	1-18028-2	WASHER, FLAT, REG M4	119	
-	1	1	2844908-1	SCREW, LOCKING	99	
-	1	1	2844907-1	POST, LOCKING	98	
-	1	1	455888-4	SPACER, CRIMPER	82	
-	1	1	1803607-1	DOCUMENTATION PACKAGE	71	
-	1	1	2119740-1	TAG, IDENTIFICATION	67	
-	2	2	2168078-1	SCREW, DRIVE, RH, RoHS, 2 x .188	66	
-	1	1	5-18022-5	SCR, HEX HD CAP, M4 X 6.0	59	
-	1	1	1338685-1	PAWL, FEED	56	
-	2	2	2-2168083-5	SCR, SKT HD CAP, RoHS, M4 X 14	53	
-	1	1	5018030-1	NUT, HEX, REG, RoHS, M3	52	
-	1	1	811242-5	BUMPER, HOLD DOWN	51	
-	1	1	690753-2	SPACER, TONKER	50	
-	1	2	18023-9	SCR, SKT HD CAP M4 X 6.0	49	
-	-	1	2119652-1	FEED CAM, PRE FEED	48	
-	1	1	1803602-1	SCR, BHSC, RoHS (M8 X 25)	41	
-	1	1	1752356-1	SUPPORT, TERMINAL	34	
-	2	2	2079383-5	SCR, BHSC, RoHS (M4 X 20)	33	
-	2	2	3-2844962-2	SPACER, CYLINDRICAL, STRIP GUIDE	30	
-	1	1	2844992-4	ASSEMBLY, STRIP GUIDE	29	
-	1	1	1-455888-0	SPACER, CRIMPER	28	
-	1	1	240792-1	DRAG, TERMINAL	25	
-	1	1	1320928-2	STRIP GUIDE	24	
-	1	1	2168083-2	SCR, SKT HD CAP, RoHS, M4 X 8.0	21	
-	1	1	1-18028-2	WASHER, FLAT, REG M4	20	
-	1	1	2119533-1	STRIPPER, SIDE FEED	19	
-	1	1	2119806-1	INSERT, SHEAR	13	
-	1	1	3-22280-3	SPRING, COMPRESSION	12	
-	1	1	1-356885-3	STOP, SHEAR	11	
-	1	1	2119805-1	SHEAR HOLDER, FRONT	10	
-	1	1	454276-5	FLOATING SHEAR, FRONT	9	
-	1	1	1	5-1633139-6	ANVIL, COMBINATION	8
-	1	1	240641-5	SPACER	7	
-	-	-	-	-	6	
-	1	1	2119757-8	DEPRESSOR, SHEAR	5	
-	1	1	4-238011-5	BLOCK, CRIMPER SPACER	4	
1	1	1	3-1803018-1	CRIMPER, INSULATION O	3	
-	1	1	455888-6	SPACER, CRIMPER	2	
1	1	1	3-456410-7	CRIMPER, WIRE PREMIUM	1	

DIMENSIONS:		TOLERANCES UNLESS OTHERWISE SPECIFIED:		MATERIAL:		FINISH:	
mm	0 PLC ±	1 PLC ±	2 PLC ±	3 PLC ±	4 PLC ±	ANGLES ±	

OWN	C. CHEN	15AUG2013
CHK	U. GUO	15AUG2013
APVD	J. CRUZ	15AUG2013
PRODUCT SPEC		
APPLICATION SPEC		
SIZE	CAGE CODE	DRAWING NO
A1	00779	2266018
Customer Accessible Production Drawing		
SCALE	1:2	SHEET 3 OF 4

LOC		DIST		REVISIONS			
A	66	P	LTM	DESCRIPTION	DATE	OWN	APVD
		-		SEE SHEET 1			

FEED TYPE MECHANICAL



PNEUMATIC

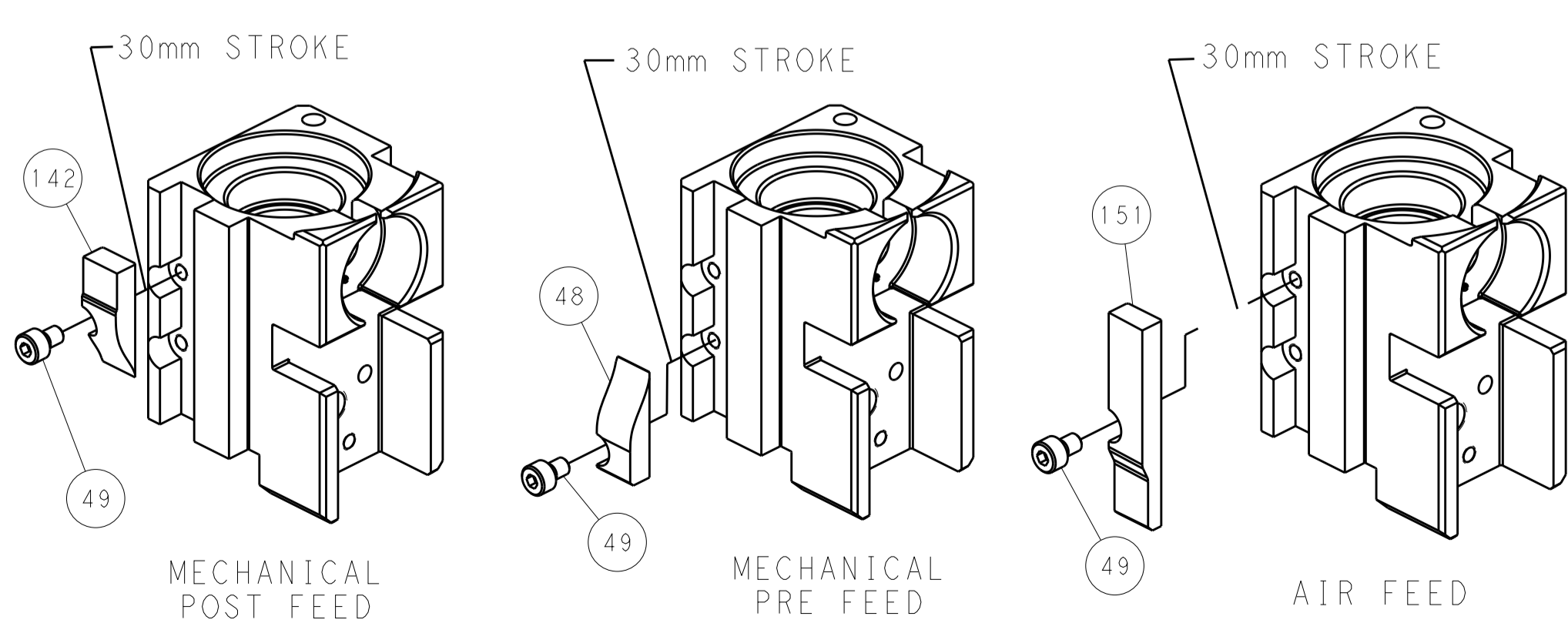
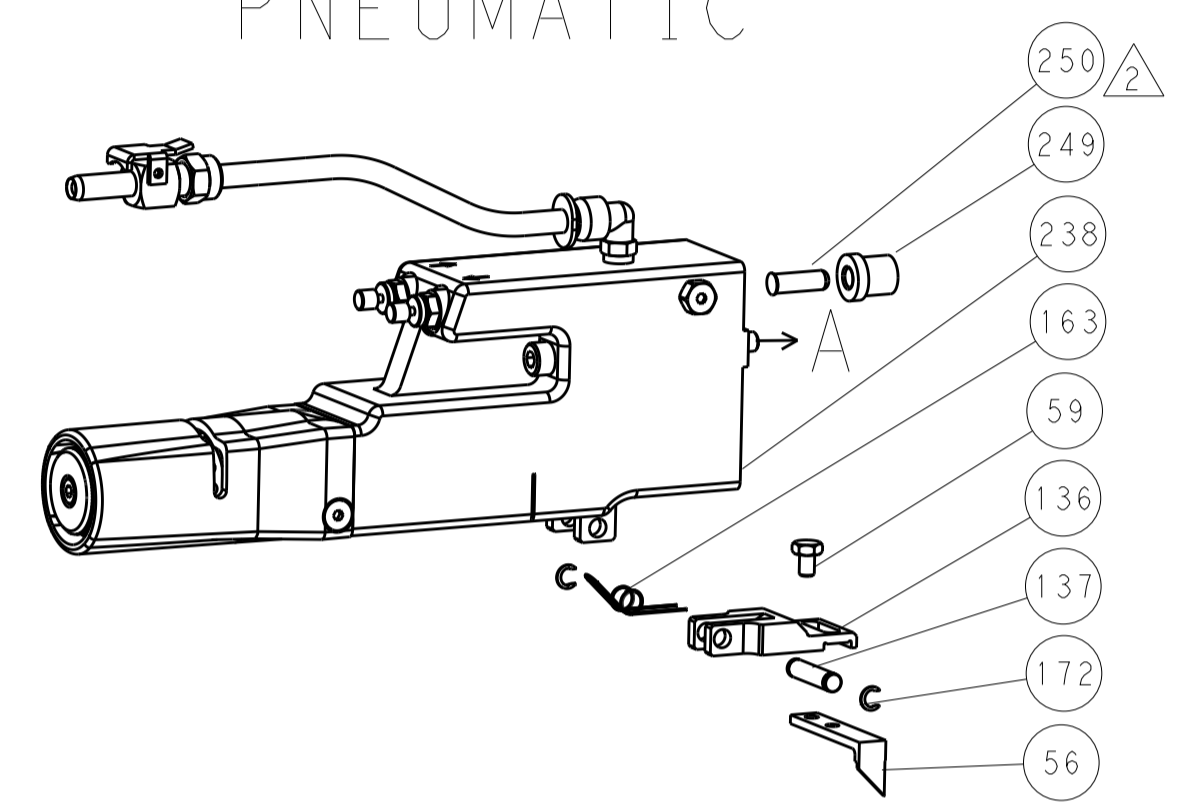

CAM POSITIONS

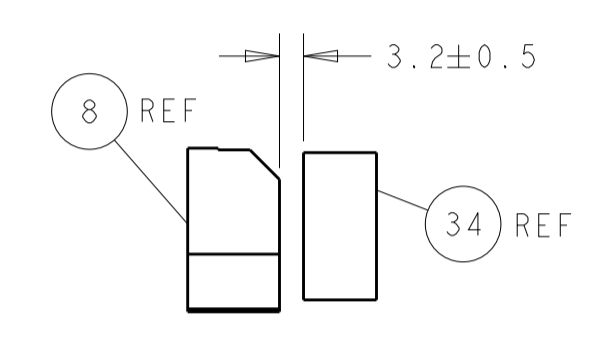
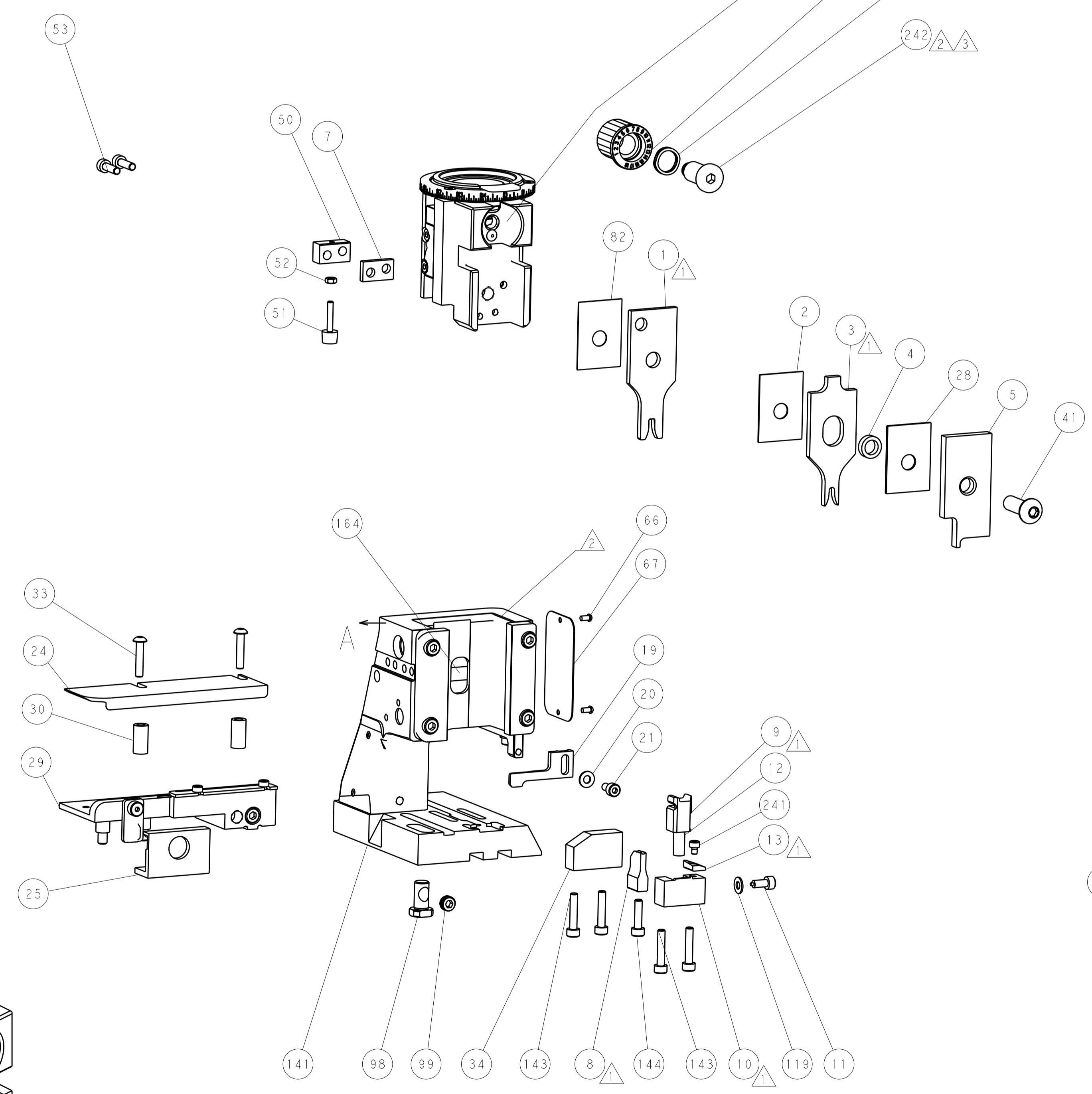

TERMINAL SUPPORT LOCATION

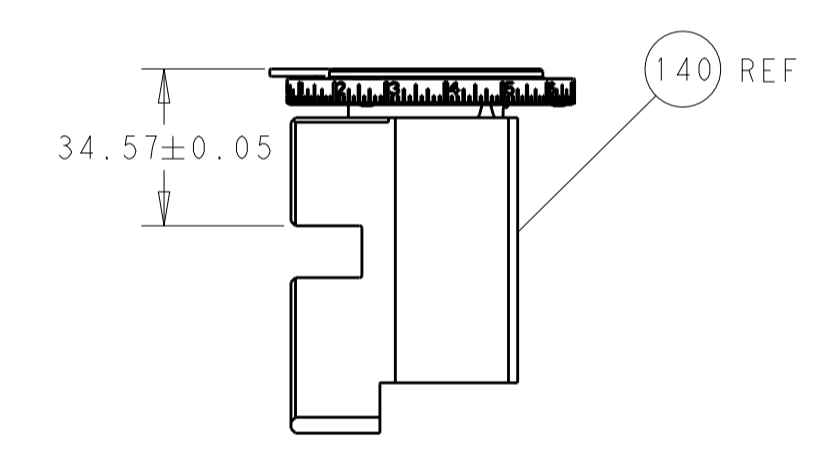

RAM SET-UP

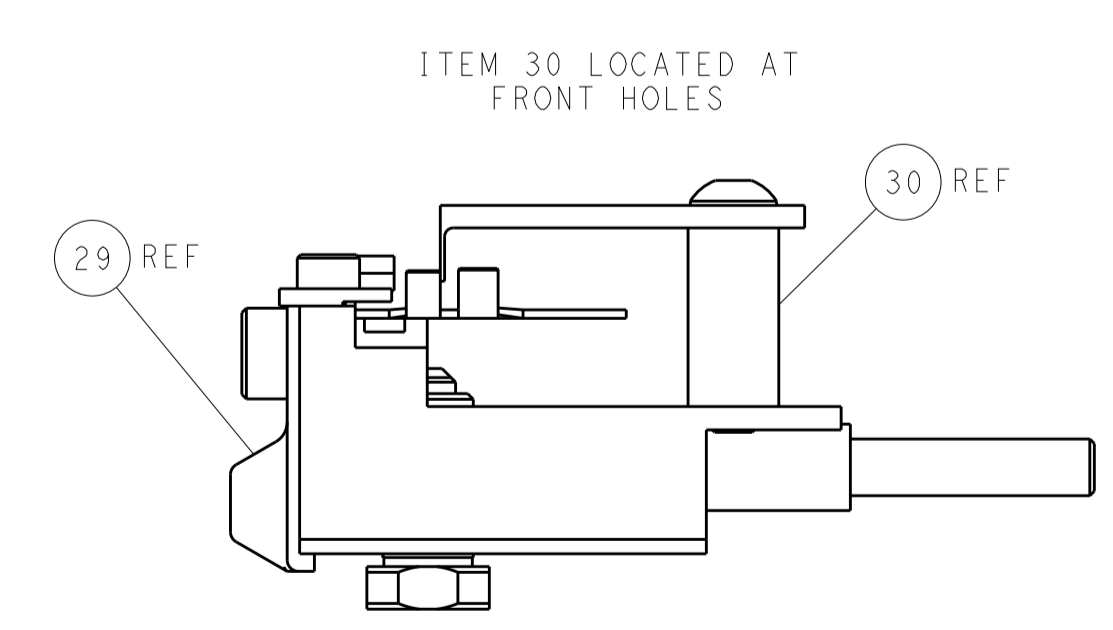

FEED TRACK POSITION GUIDE BY INSULATION BARREL

PACIFIC VERSION
 Shown on sheets 3 of 4 & 4 of 4
 (Atlantic version shown on sheets 1 of 4 & 2 of 4)

DIMENSIONS:		TOLERANCES UNLESS OTHERWISE SPECIFIED:		DWN: C. CHEN 15AUG2013		CHK: U. GUO 15AUG2013		APVD: J. CRUZ 15AUG2013		NAME: Ocean Side Feed Applicator	
mm	0 PLC	±		SIZE	CAGE CODE	DRAWING NO	RESTRICTED TO	STE TE Connectivity Harrisburg, PA 17105-3608			
	1 PLC	±		SCALE	00779	©=2266018		Customer Accessible Production Drawing			
	2 PLC	±		SCALE	1:2			SHEET 4 OF 4 REV C			
	3 PLC	±		SHEETS 1 & 2 ARE NOT REQUIRED FOR PACIFIC VERSION							
	4 PLC	±									
	ANGLES	±									
MATERIAL	FINISH										