

REVISIONS			
REV.	DESCRIPTION	DATE	APPROVED
A	INITIAL RELEASE	01/10/11	D.N.

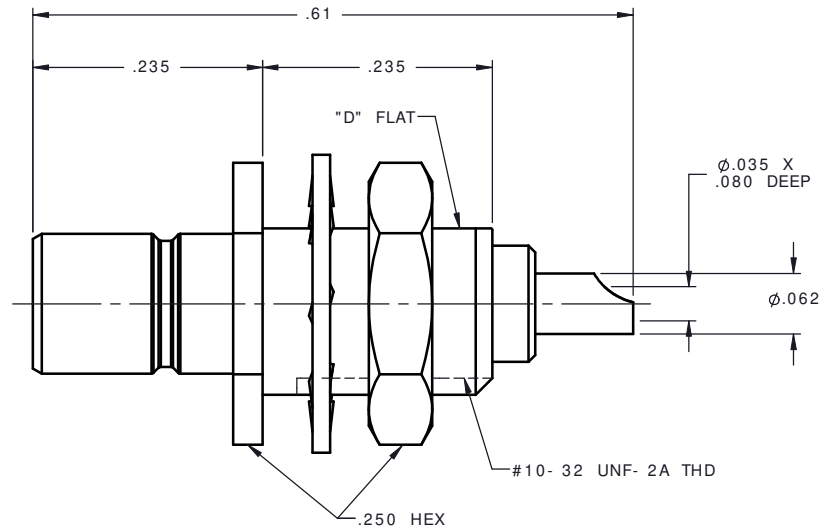



NOTES:

MATERIALS:

1. INSULATOR = VIRGIN WHITE TEFLON PER ASTM D1710, GRADE 1, TYPE I, CLASS "B".
2. LOCKWASHER = PHOSPHOR BRONZE PER ASTM B139, COPPER ALLOY C53400, TEMPER H04.
3. ALL OTHER METAL PARTS = BRASS PER ASTM B16, ALLOY C36000, TEMPER H02.

FINISHES:

1. CONTACT = GOLD PLATE PER MIL- G- 45204, TYPE II, CLASS 1, GRADE C, OVER .00010 TO .00020 STRESS FREE SULFAMATE NICKEL PER QQ- N- 290.
2. ALL OTHER METAL PARTS = GOLD PLATE PER MIL- G- 45204, TYPE II, CLASS 0, GRADE C, OVER .00010 TO .00020 COPPER STRIKE PER MIL- C- 14550.

UNLESS OTHERWISE SPECIFIED DIMENSIONS ARE IN INCHES TOLERANCES ON		DWN: DATE D.N. 01/10/11	 Property of Radiall This document cannot be reproduced or communicated to a third party without prior written permission of RADIALL.	
DECIMAL	ANGLE	CHKD: DATE A.D.M. 01/10/11		
		APVD: DATE J.M. 01/10/11	<b>SMB STRAIGHT MALE JACK          BULKHEAD FRONT MOUNT          SOLDER POT RECEPTACLE</b>	
REFERENCE:		MATERIALS & FINISHES: SEE NOTES		
ORIGINATED: D.N. DATE: 01/10/11			DWG NO. <b>2019-1511-000</b>	REV A
			SCALE 7:1	THIRD ANGLE PROJECTION 
			SHEET 1 OF 1	

2019-1511-000