

# MCT6, MCT61, MCT62 Dual Phototransistor Optocouplers

## Features

- Two isolated channels per package
- Two packages fit into a 16 lead DIP socket
- Choice of three current transfer ratios
- Underwriters Laboratory (U.L.) recognized File E90700
- VDE approved for IEC60747-5-2

## Applications

- AC line/digital logic – isolate high voltage transients
- Digital logic/digital logic – eliminate spurious grounds
- Digital logic/AC triac control – isolate high voltage transients
- Twisted pair line receiver – eliminate ground loop feedthrough
- Telephone/telegraph line receiver – isolate high voltage transients
- High frequency power supply feedback control – maintain floating grounds and transients
- Relay contact monitor – isolate floating grounds and transients
- Power supply monitor – isolate transients

## Description

The MCT6X Optocouplers have two channels for density applications. For four channel applications, two-packages fit into a standard 16-pin DIP socket. Each channel is an NPN silicon planar phototransistor optically coupled to a gallium arsenide infrared emitting diode.

## Schematic

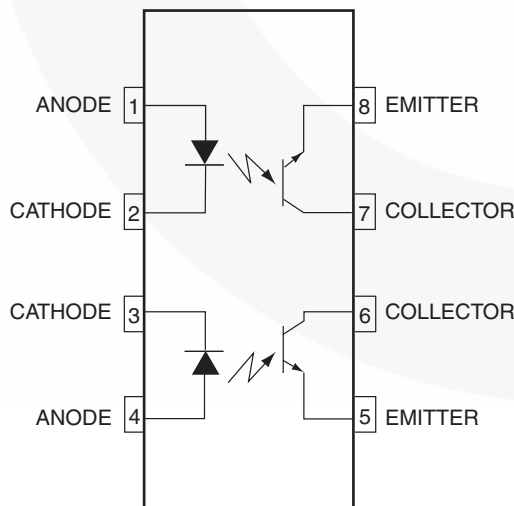

Equivalent Circuit

## Package Outlines

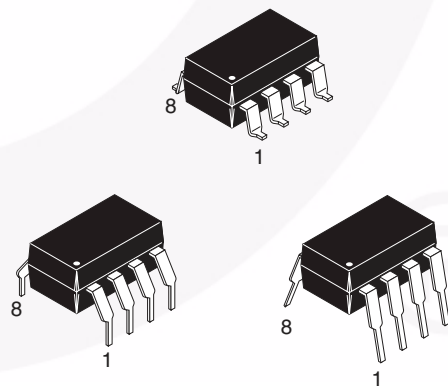

## Absolute Maximum Ratings

Stresses exceeding the absolute maximum ratings may damage the device. The device may not function or be operable above the recommended operating conditions and stressing the parts to these levels is not recommended. In addition, extended exposure to stresses above the recommended operating conditions may affect device reliability. The absolute maximum ratings are stress ratings only.

Symbol	Rating	Value	Unit
<b>TOTAL DEVICE</b>			
$T_{STG}$	Storage Temperature	-55 to +150	°C
$T_{OPR}$	Operating Temperature	-55 to +100	°C
$T_{SOL}$	Lead Solder Temperature (Refer to Reflow Temperature Profile)	260 for 10 sec	°C
$P_D$	Total Device Power Dissipation @ $T_A = 25^\circ\text{C}$	400	mW
	Derate above $25^\circ\text{C}$	5.33	mW/°C
<b>EMITTER (Each channel)</b>			
$I_F$	Forward Current – Continuous	60	mA
$I_F(pk)$	Forward Current – Peak (PW = 1 $\mu$ s, 300pps)	3	A
$V_R$	Reverse Voltage	3.0	V
$P_D$	LED Power Dissipation @ $T_A = 25^\circ\text{C}$	100	mW
	Derate above $25^\circ\text{C}$ (Total Input)	1.3	mW/°C
<b>DETECTOR (Each channel)</b>			
$I_C$	Collector Current – Continuous	30	mA
$P_D$	Detector Power Dissipation @ $T_A = 25^\circ\text{C}$	150	mW
	Derate above $25^\circ\text{C}$	2.0	mW/°C

**Electrical Characteristics** ( $T_A = 25^\circ\text{C}$  unless otherwise specified)**Individual Component Characteristics**

Symbol	Parameter	Test Conditions	Min.	Typ.*	Max.	Units
<b>EMITTER</b>						
$V_F$	Input Forward Voltage	$I_F = 20\text{mA}$		1.2	1.5	V
$V_R$	Reverse Voltage	$I_R = 10\mu\text{A}$	3.0	25		V
$I_R$	Reverse Current	$V_R = 5\text{V}$		0.001	10	$\mu\text{A}$
$C_J$	Junction Capacitance	$V_F = 0\text{V}$ , $f = 1\text{MHz}$		50		pF
<b>DETECTOR</b>						
$BV_{CEO}$	Collector-Emitter Breakdown Voltage	$I_C = 1.0\text{mA}$ , $I_F = 0$	30	85		V
$BV_{ECO}$	Emitter-Collector Breakdown Voltage	$I_E = 100\mu\text{A}$ , $I_F = 0$	6	13		V
$I_{CEO}$	Collector-Emitter Dark Current	$V_{CE} = 10\text{V}$ , $I_F = 0$		5	100	nA
$C_{CE}$	Capacitance	$V_{CE} = 0\text{V}$ , $f = 1\text{MHz}$		8		pF

**Transfer Characteristics**

Symbol	Characteristic	Test Conditions	Min.	Typ.*	Max.	Units
<b>SWITCHING CHARACTERISTICS (AC)</b>						
$t_{on}$	Non-Saturated Turn-on Time	$R_L = 100\Omega$ , $I_C = 2\text{mA}$ , $V_{CC} = 10\text{V}$		2.4		$\mu\text{s}$
$t_{off}$	Non-Saturated Turn-off Time			2.4		$\mu\text{s}$
<b>CURRENT TRANSFER RATIO, COLLECTOR-EMITTER (DC)</b>						
CTR	MCT6	$I_F = 10\text{mA}$ , $V_{CE} = 10\text{V}$	20			%
	MCT61	$I_F = 5\text{mA}$ , $V_{CE} = 5\text{V}$	50			
	MCT62		100			
$V_{CE(sat)}$	Saturation Voltage	$I_F = 16\text{mA}$ , $I_C = 2\text{mA}$		0.15	0.40	V

**Isolation Characteristics**

Symbol	Characteristic	Test Conditions	Min.	Typ.*	Max.	Units
$V_{ISO}$	Input-Output Isolation Voltage	$I_{I-O} \leq 10\mu\text{A}$ , $t = 1\text{min.}$	5000			Vac(rms)
$R_{ISO}$	Isolation Resistance	$V_{I-O} = 500\text{VDC}$	$10^{11}$			$\Omega$
$C_{ISO}$	Isolation Capacitance	$f = 1\text{MHz}$		0.5		pF

\*All typicals at  $T_A = 25^\circ\text{C}$

## Typical Performance Curves

Fig. 1 Normalized CTR vs. Forward Current

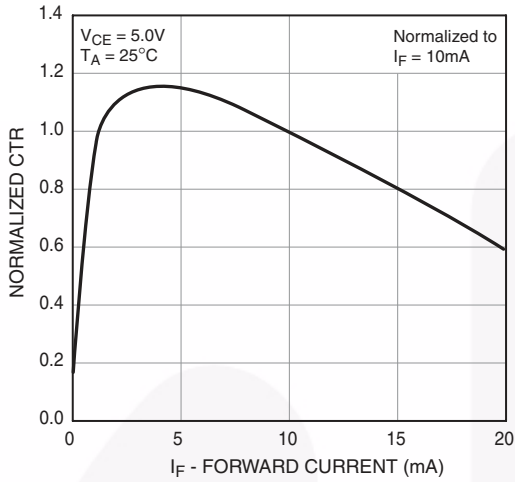

Fig. 2 Normalized CTR vs. Ambient Temperature

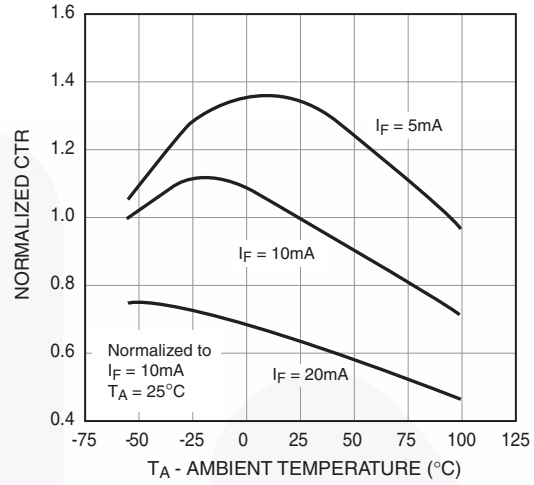

Fig. 3 Dark Current vs. Ambient Temperature

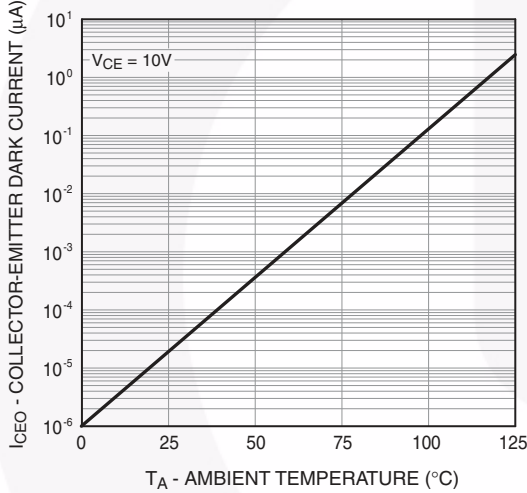

Fig. 4 Switching Speed vs. Load Resistor

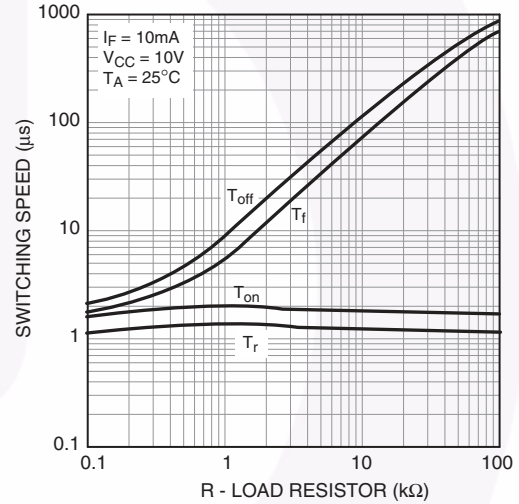

Fig. 5 LED Forward Voltage vs. Forward Current

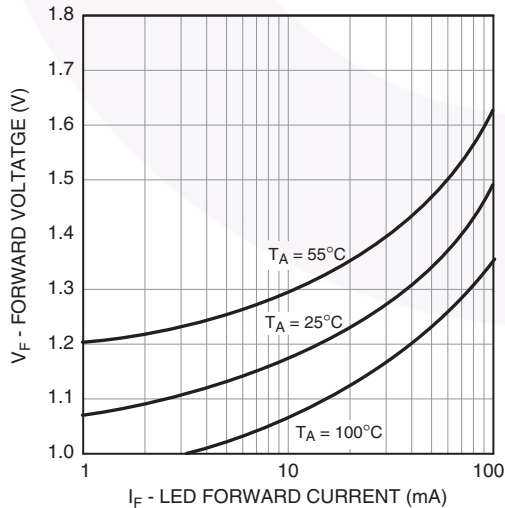
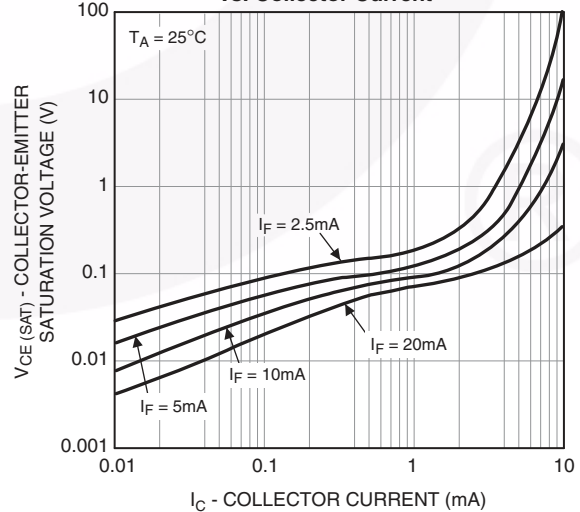
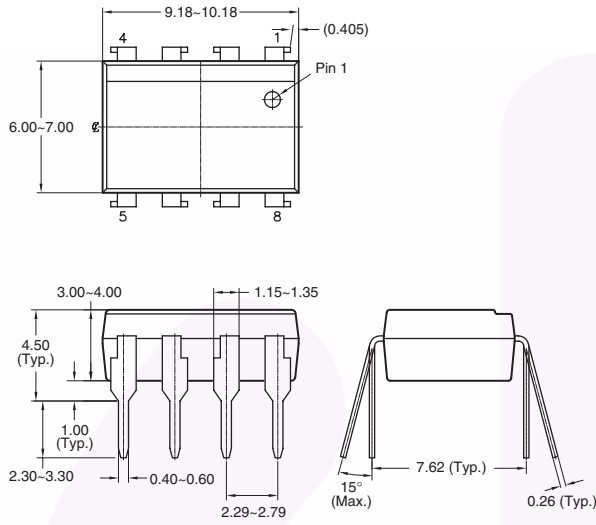

Fig. 6 Collector-Emitter Saturation Voltage vs. Collector Current



## Package Dimensions

### Through Hole



### Surface Mount

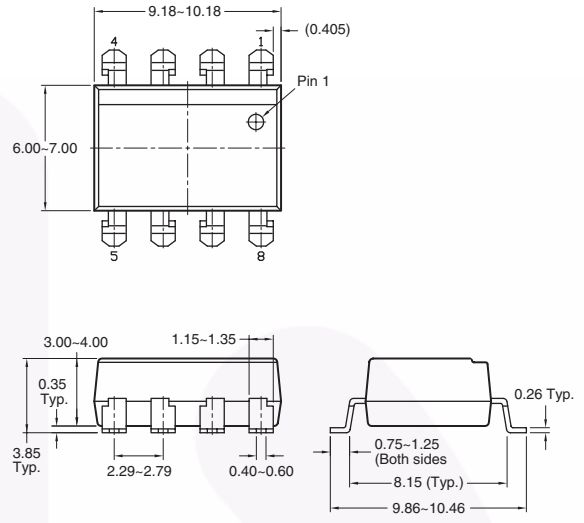

### 0.4" Lead Spacing

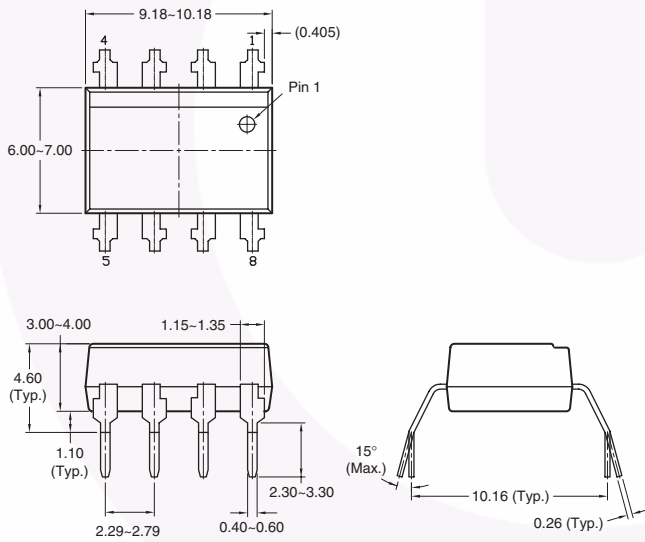

### Recommend Pad Layout for Surface Mount Leadform

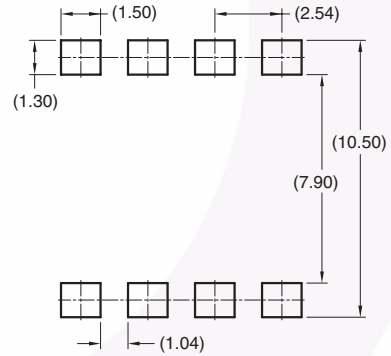

**Note:**

All dimensions are in millimeters.

### Ordering Information

Option	Example Part Number	Description
No Option	MTC6	Standard Through Hole
S	MTC6S	Surface Mount Lead Bend
SD	MTC6SD	Surface Mount; Tape and Reel
300	MCT6300	VDE Approved
3S	MCT63S	Surface Mount Lead Bend; VDE Approved
3SD	MCT63SD	Surface Mount; Tape and Reel; VDE Approved
300W	MTC6300W	0.4" Lead Spacing; VDE Approved

### Marking Information

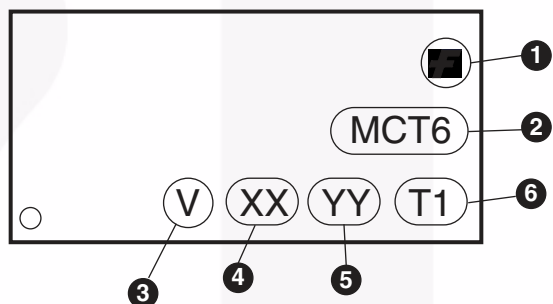

Definitions	
1	Fairchild logo
2	Device number
3	VDE mark (Note: Only appears on parts ordered with VDE option – See order entry table)
4	Two digit year code, e.g., '03'
5	Two digit work week ranging from '01' to '53'
6	Assembly package code

### Carrier Tape Specifications

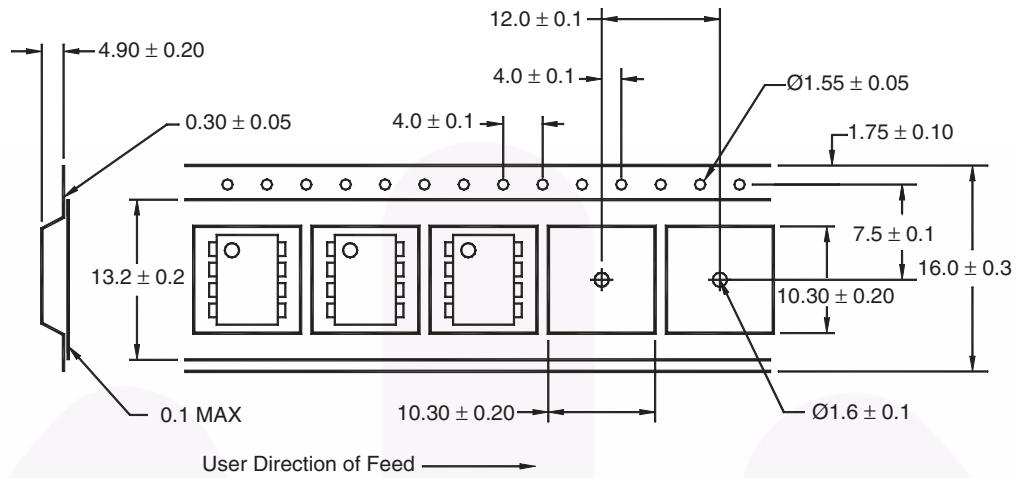

**Note:**  
All dimensions are in inches (millimeters)

### Reflow Profile

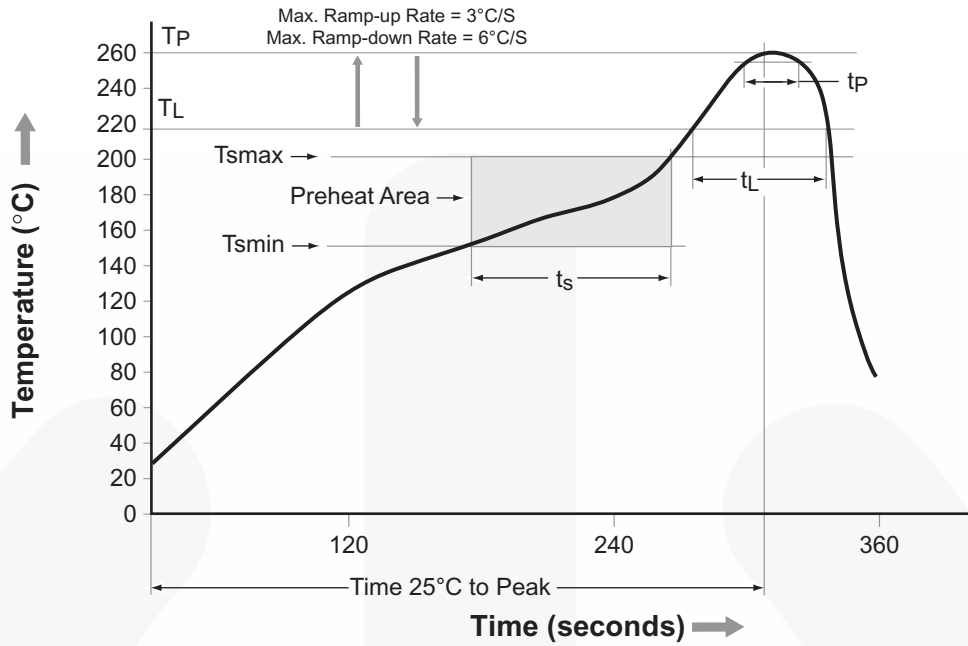



Profile Feature	Pb-Free Assembly Profile
Temperature Min. ( $T_{smin}$ )	150°C
Temperature Max. ( $T_{smax}$ )	200°C
Time ( $t_s$ ) from ( $T_{smin}$ to $T_{smax}$ )	60–120 seconds
Ramp-up Rate ( $t_L$ to $t_p$ )	3°C/second max.
Liquidous Temperature ( $T_L$ )	217°C
Time ( $t_L$ ) Maintained Above ( $T_L$ )	60–150 seconds
Peak Body Package Temperature	260°C +0°C / -5°C
Time ( $t_p$ ) within 5°C of 260°C	30 seconds
Ramp-down Rate ( $T_P$ to $T_L$ )	6°C/second max.
Time 25°C to Peak Temperature	8 minutes max.





Auto-SPM™  
 Build it Now™  
 CorePLUS™  
 CorePOWER™  
 CROSSVOLT™  
 CTL™  
 Current Transfer Logic™  
 DEUXPEED®  
 Dual Cool™  
 EcoSPARK®  
 EfficientMax™  
 F®  
 Fairchild®  
 Fairchild Semiconductor®  
 FACT Quiet Series™  
 FACT®  
 FAST®  
 FastvCore™  
 FETBench™  
 FlashWriter®\*  
 FPS™  
 F-PFS™

Global Power Resource™  
 Green FPS™  
 Green FPS™ e-Series™  
 Gmax™  
 GTO™  
 IntelliMAX™  
 ISOPLANAR™  
 MegaBuck™  
 MICROCOUPLER™  
 MicroFET™  
 MicroPak™  
 MicroPak2™  
 MillerDrive™  
 MotionMax™  
 Motion-SPM™  
 OptoHiT™  
 OPTOLOGIC®  
 OPTOPLANAR®  
 PDP SPM™  
 Power-SPM™

PowerXS™  
 Programmable Active Droop™  
 QFET®  
 QS™  
 Quiet Series™  
 RapidConfigure™  
  
 Saving our world, 1mW/W/kW at a time™  
 SignalWise™  
 SmartMax™  
 SMART START™  
 SPM®  
 STEALTH™  
 SuperFET™  
 SuperSOT™-3  
 SuperSOT™-6  
 SuperSOT™-8  
 SupreMOS™  
 SyncFET™  
 Sync-Lock™  

power franchise™  
 TinyBoost™  
 TinyBuck™  
 TinyCalc™  
 TinyLogic®  
 TINYOPTO™  
 TinyPower™  
 TinyPWM™  
 TinyWire™  
 TriFault Detect™  
 TRUECURRENT™\*  
 μSerDes™  
  
 UHC®  
 Ultra FRFET™  
 UniFET™  
 VCX™  
 VisualMax™  
 XS™

\* Trademarks of System General Corporation, used under license by Fairchild Semiconductor.

**DISCLAIMER**

FAIRCHILD SEMICONDUCTOR RESERVES THE RIGHT TO MAKE CHANGES WITHOUT FURTHER NOTICE TO ANY PRODUCTS HEREIN TO IMPROVE RELIABILITY, FUNCTION, OR DESIGN. FAIRCHILD DOES NOT ASSUME ANY LIABILITY ARISING OUT OF THE APPLICATION OR USE OF ANY PRODUCT OR CIRCUIT DESCRIBED HEREIN; NEITHER DOES IT CONVEY ANY LICENSE UNDER ITS PATENT RIGHTS, NOR THE RIGHTS OF OTHERS. THESE SPECIFICATIONS DO NOT EXPAND THE TERMS OF FAIRCHILD'S WORLDWIDE TERMS AND CONDITIONS, SPECIFICALLY THE WARRANTY THEREIN, WHICH COVERS THESE PRODUCTS.

**LIFE SUPPORT POLICY**

FAIRCHILD'S PRODUCTS ARE NOT AUTHORIZED FOR USE AS CRITICAL COMPONENTS IN LIFE SUPPORT DEVICES OR SYSTEMS WITHOUT THE EXPRESS WRITTEN APPROVAL OF FAIRCHILD SEMICONDUCTOR CORPORATION.

As used herein:

1. Life support devices or systems are devices or systems which, (a) are intended for surgical implant into the body or (b) support or sustain life, and (c) whose failure to perform when properly used in accordance with instructions for use provided in the labeling, can be reasonably expected to result in a significant injury of the user.
2. A critical component in any component of a life support, device, or system whose failure to perform can be reasonably expected to cause the failure of the life support device or system, or to affect its safety or effectiveness.

**ANTI-COUNTERFEITING POLICY**

Fairchild Semiconductor Corporation's Anti-Counterfeiting Policy. Fairchild's Anti-Counterfeiting Policy is also stated on our external website, [www.fairchildsemi.com](http://www.fairchildsemi.com), under Sales Support.

Counterfeiting of semiconductor parts is a growing problem in the industry. All manufacturers of semiconductor products are experiencing counterfeiting of their parts. Customers who inadvertently purchase counterfeit parts experience many problems such as loss of brand reputation, substandard performance, failed applications, and increased cost of production and manufacturing delays. Fairchild is taking strong measures to protect ourselves and our customers from the proliferation of counterfeit parts. Fairchild strongly encourages customers to purchase Fairchild parts either directly from Fairchild or from Authorized Fairchild Distributors who are listed by country on our web page cited above. Products customers buy either from Fairchild directly or from Authorized Fairchild Distributors are genuine parts, have full traceability, meet Fairchild's quality standards for handling and storage and provide access to Fairchild's full range of up-to-date technical and product information. Fairchild and our Authorized Distributors will stand behind all warranties and will appropriately address any warranty issues that may arise. Fairchild will not provide any warranty coverage or other assistance for parts bought from Unauthorized Sources. Fairchild is committed to combat this global problem and encourage our customers to do their part in stopping this practice by buying direct or from authorized distributors.

**PRODUCT STATUS DEFINITIONS**

**Definition of Terms**

Product Definition	Product Status	Product Definition
--------------------	----------------	--------------------