

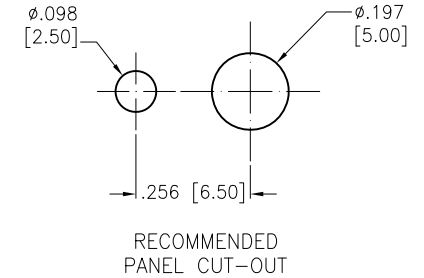

APPROVED: _____
 DATE: _____ TITLE: _____

Rev	AWO #	Description	Date	Appr
-		RELEASED	11/19/20	
A		UPDATED SPEC.	5/27/22	JJ/MC
B		UPDATED SPEC.	11/22/22	WX/AC1

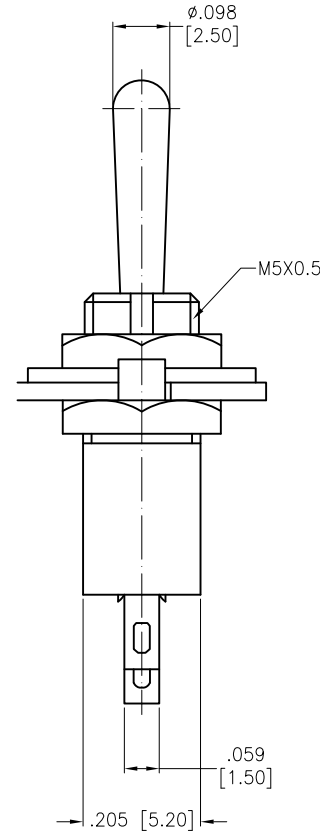
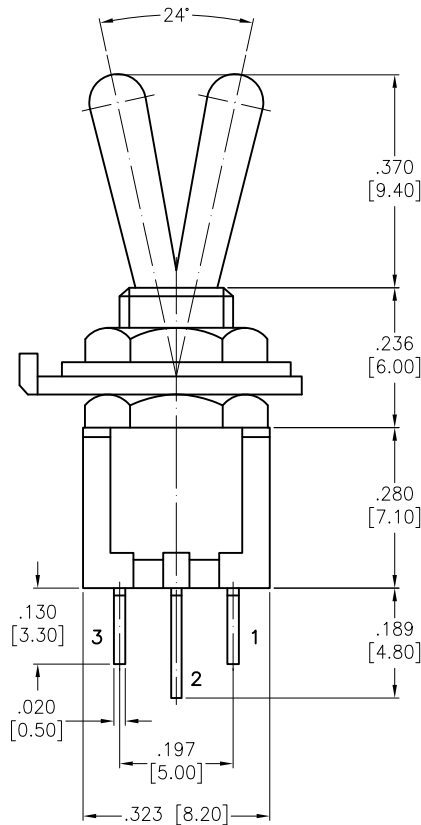

POSITION		
TERMINALS	2-1	2-3

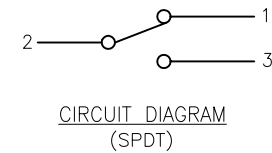

SPECIFICATIONS:

Material:
 Body: PA66, Color: Blue 
 Lever: Brass, Nickel plated
 Terminal: Brass, Silver plated
 Electrical:

Rating: 1.5A @ 250V AC
 3A @ 125V AC

Contact resistance: 20 mΩ max

Insulation resistance: 1000 MΩ min (500VDC)

Dielectric withstanding voltage: 1000V AC for 1 minute

Electrical Life: 10,000 cycles

Temperature Rating:

Operating temperature: -25°C to +85°C

Environmental:

Lead free, RoHS compliant



UNLESS OTHERWISE SPECIFIED ALL DIMENSIONS ARE INCHES [MM]. TOLERANCES: EXCEPT AS NOTED

INCHES	HOLES
.X ± .10	ØX ± .10
.XX ± .020	ØXX ± .015
.XXX ± .015	ØXXX ± .010

DRAWN	OW	11/19/20
CHECKED	AC	11/19/20
APPROVED		

THIS DRAWING CONTAINS INFORMATION THAT IS PROPRIETARY AND SHOULD NOT BE USED WITHOUT PRIOR WRITTEN PERMISSION FROM ADAM TECH

**ADAM
 TECH**

909 Rahway Avenue,
 Union, NJ 07083
 Phone: 908-687-5000
 Fax: 908-687-5710

TITLE SWITCH, TOGGLE SUB-MINIATURE, SPDT, ON-ON, SOLDER TYPE

SIZE X	PART NO. SW-T3-2B-A-A3-S1	REV. B
REF: S00206C	SCALE: NTS	SHEET 1 OF 1