

THIS DRAWING IS UNPUBLISHED. RELEASED FOR PUBLICATION
 © COPYRIGHT BY

REVISIONS						
P	F	ZONE	LTR	DESCRIPTION	DATE	APPROVED
		P1		REVISED PER ECO-11-005294	08APR11	HMR

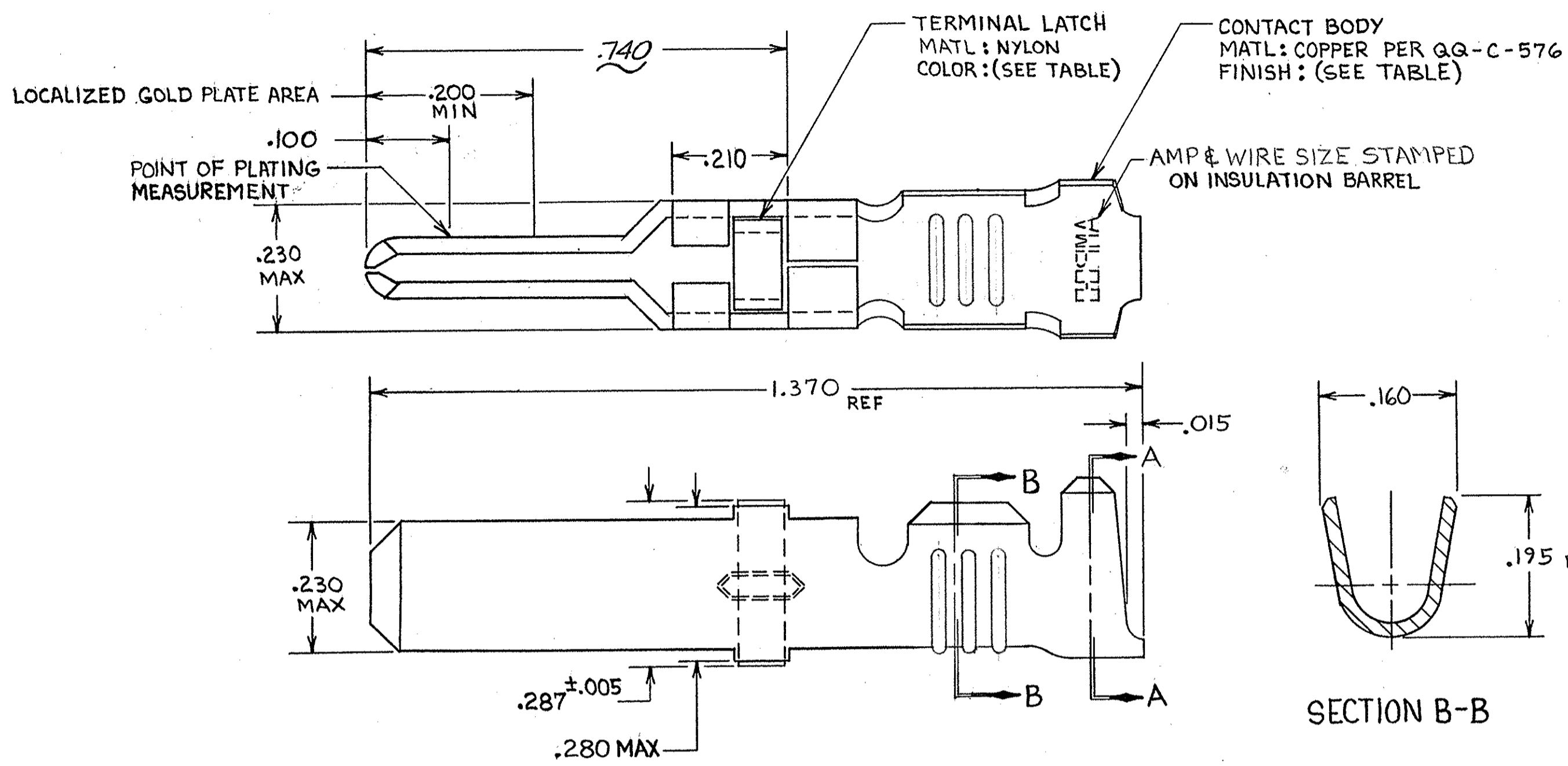

- 1. REELED FOR USE WITH STANDARD APPLICATORS.
- 2. REELED FOR USE WITH HEAVY DUTY MINI-APPLICATORS.
- 3. PLATED WITH .000100 MIN SILVER PER QQ-S-365.
- 4. PLATED WITH .000015 MIN GOLD PER MIL-G-45204 IN THE LOCALIZED GOLD PLATE AREA; GOLD FLASH ON THE REMAINDER, OVER .000030 MIN NICKEL PER QQ-N-290.
- 5. PLATED WITH .000030 MIN GOLD PER MIL-G-45204 IN THE LOCALIZED GOLD PLATE AREA, GOLD FLASH ON THE REMAINDER, OVER .000030 MIN NICKEL PER QQ-N-290.
- 6. PLATED WITH .000050 MIN 93-7% TIN-LEAD ALLOY OVER .000030 MIN NICKEL PER QQ-N-290.
- 7. WIRE RANGE = 12-16 AWG.
- 8. INSULATION RANGE = .140-.165 DIA.
- 9. PLATED TIN (NOLEAD). 0.000050 MIN THK PER ASTM-B-545 OVER NICKEL. 0.000030 MIN THK PER QQ-N-290.

TERMINAL LATCH COLOR	FINISH	STRIP ASS'Y P/N REF	STRIP ASS'Y P/N REF	LOOSE PIECE P/N REF
BLACK	4	66256-9/2	66256-8	66262-5
NATURAL	3		66256-6	66262-4
BLACK	4		66256-7	66262-3
BLACK	5	66256-4	66256-2	66262-2
BLACK	6	66256-5	66256-1	66262-1

UNLESS OTHERWISE SPECIFIED DIMENSIONS ARE IN INCHES. TOLERANCES ON: DECIMALS ±.010 ANGLES ±.010	CONTRACT NO		TE Connectivity NAME MALE TYPE XII GROUND CONTACT LOOSE PIECE ASS'Y	
	MATERIAL SEE CALLOUT	DR <i>Rick Rolbaugh</i> 9-27-85		
FINISH SEE DASH NO	APPD <i>S. J. Boland</i> 10-25-85	APPD <i>James E. Smith</i> 10-28-85	SIZE C	FSCM NO 00779
	OTHER APPD		DRAWING NO 66262	SHEET
			SCALE NTS	

66262