

1. INTRODUCTION

This instruction sheet covers the installation and operation of the AGASTAT* 7000 Series 2-Pole Timing Relays (Models 7012, 7022, and 7032). Read these instructions thoroughly before installing the relay.



Dimensions in this instruction sheet are in millimeters [with inches in brackets]. Figures are not drawn to scale.

2. DESCRIPTION (Figure 1)

Each relay is a precise timing instrument which balances pneumatic, electrical, and mechanical forces using a minimum of moving parts.

3. MOUNTING INSTRUCTIONS (Figure 2)

3.1. Vertical Mounting

Normal mounting of the relay is in a vertical position, from the back of the panel. Four No. 8-32 tapped holes are provided in the back plate.



Mounting screws should not project more than 3.63 mm [5/32 in.] into the back of the unit, to prevent internal damage.

A bracket and required screws are supplied with each unit for mounting the unit from the front. The bracket extends approximately 9.52 mm [3/8 in.] from each side of the unit.

3.2. Horizontal Mounting

For horizontal operation, order the X or Y1 option.

4. AUXILIARY SWITCH ADJUSTMENT (Figure 3)

4.1. Model 7012

A. Instant Transfer (Code L or Code LL)

The switch should transfer immediately when relay coil is energized and should reset shortly before solenoid core returns to its normal position, following de-energization. Switch travel is set at the factory.

B. Two Step (Code T)

The switch contacts should transfer following first delay period after coil energization and should reset shortly before core returns to its normal position, following coil de-energization. Switch travel is set at the factory.

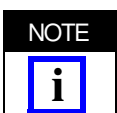

First delay is independently adjustable, but must be no more than 30% of overall delay. Recommended maximum is 100 seconds.

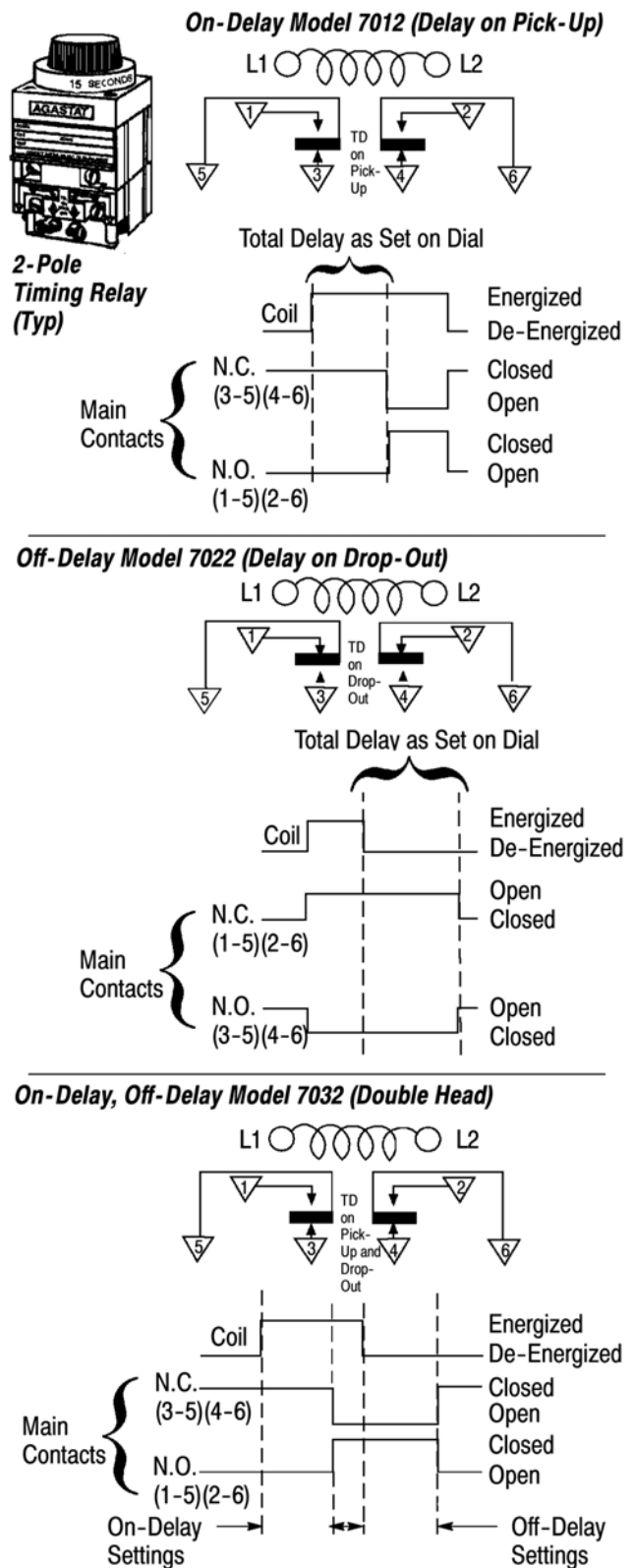

Figure 1 (Cont'd)

LINEAR TIMING RANGES		
TIME RANGE CODE	MODELS 7012 AND 7022	MODEL 7032†
A	0.1 to 1 Second	0.2 to 2 Seconds
B	0.5 to 5 Seconds	0.7 to 7 Seconds
C	1.5 to 15 Seconds	2 to 20 Seconds
D	5 to 50 Seconds	10 to 100 Seconds
E	20 to 200 Seconds	30 to 300 Seconds
F	1 to 10 Minutes	1.5 to 15 Minutes
H	3 to 30 Minutes	3 to 30 Minutes
I	6 to 60 Minutes	Not Available
J	3 to 120 Cycles	Not Available
K	1 to 300 Cycles	Not Available

Basic models are furnished with dials calibrated in linear increments covering the range selected. In addition, time-calibrated ranged B through K provide non-linear adjustment from .2 second to the beginning of the linear zone. For easiest adjustment and lowest cost, the shortest time range suitable for the application should be selected.

† Model 7032 is available with letter calibrated dials only. The upper end of the time ranges in this model may be twice the values shown.

AC COIL UNITS				
CODE LETTER	AT 60 Hz		AT 50 Hz	
	RATED VOLTAGE	VOLTAGE RANGE (Operating)	RATED VOLTAGE	VOLTAGE RANGE (Operating)
A	120	102 - 132	110	93.5 - 121
B	240	204 - 264	220	187 - 242
C	480	408 - 528	--	--
D	550	468 - 605	--	--
E	24	20.5 - 26.5	--	--
F	--	--	127	108 - 140
G	--	--	240	204 - 264
H	12	10.2 - 13.2	--	--
I	6	5.1 - 6.6	--	--
J	208	178 - 229	--	--
K	Dual Voltage Coil (Combines A and B)			

DC COIL UNITS		
CODE LETTER	RATED VOLTAGE	VOLTAGE RANGE (Operating)
M	28	22.5 - 33.5
N	48	38.5 - 57.5
O	24	19.2 - 28.8
P	125	100 - 150
Q	12	9.6 - 14.4
R	60	48 - 74
S	250	200 - 300
T	550	440 - 660
U	16	12.8 - 19.2
V	32	25.6 - 38.4
W	96	76.8 - 115
Y	6	4.8 - 7.2
Z	220	176 - 264

AC Specials L1, L2, etc. DC Specials X1, X2, etc.

All units draw approximately 8 watts power at rated voltage.

Minimum operating voltages are based on vertically mounted Model 7012 (on-delay) units. Model 7012 horizontally mounted or Model 7022 (off-delay) vertically or horizontally mounted units will operate satisfactorily at minimum voltages approximately 5% lower than those listed.

AC units drop out at approximately 50% of rated voltage. DC units drop out at approximately 10% of rated voltage.

All units may be operated on intermittent duty cycle at voltages 10% above the listed maximums. (Intermittent duty - maximum 50% duty cycle and 30 minutes "on" time.)

CONTACT RATINGS (Contact Capacity in Amperes - Resistive Loads)		
CONTACT VOLTAGE	MINIMUM 100,000 OPERATIONS	MINIMUM 1,000,000 OPERATIONS
30 Vdc	15.0	7.0
110 Vdc	1.0	0.5
120 Vac 60 Hz	20.0	15.0
240 Vac 60 Hz	20.0	15.0
480 Vac 60 Hz	12.0	10.0

Contact ratings are listed under the Underwriters Laboratories Inc. Component Recognition Program for 100,000 operations:

- 10 A Resistive, 240 Vac (per pole)
- 1/4 Horsepower, 120 Vac/240Vac (per pole)
- 15 A, 30 Vdc (per pole)
- 5 A, General Purpose, 600 Vac

Figure 1 (End)

Models 7012 and 7022 (Mounting Dimensions)

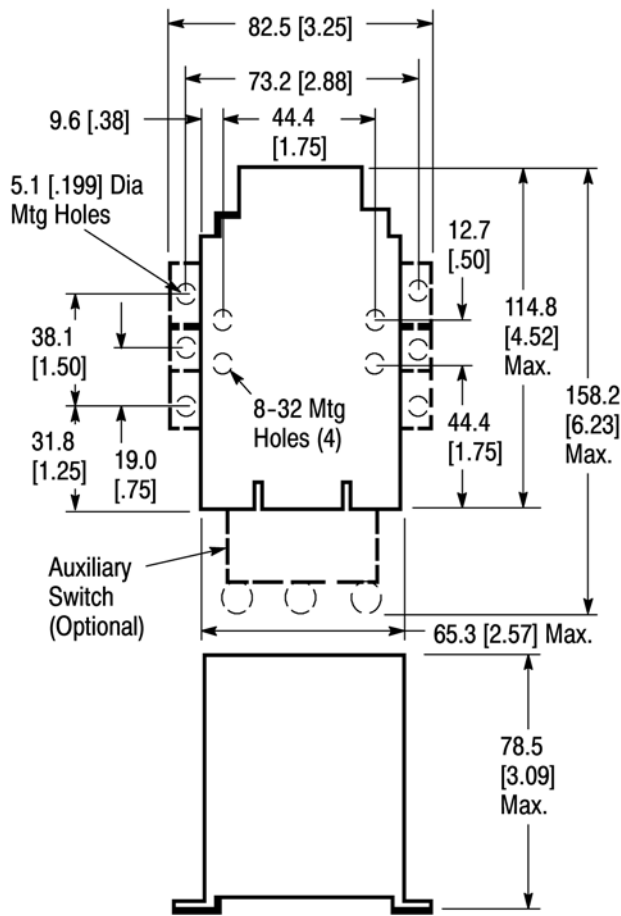

Model 7032 (Mounting Dimensions)

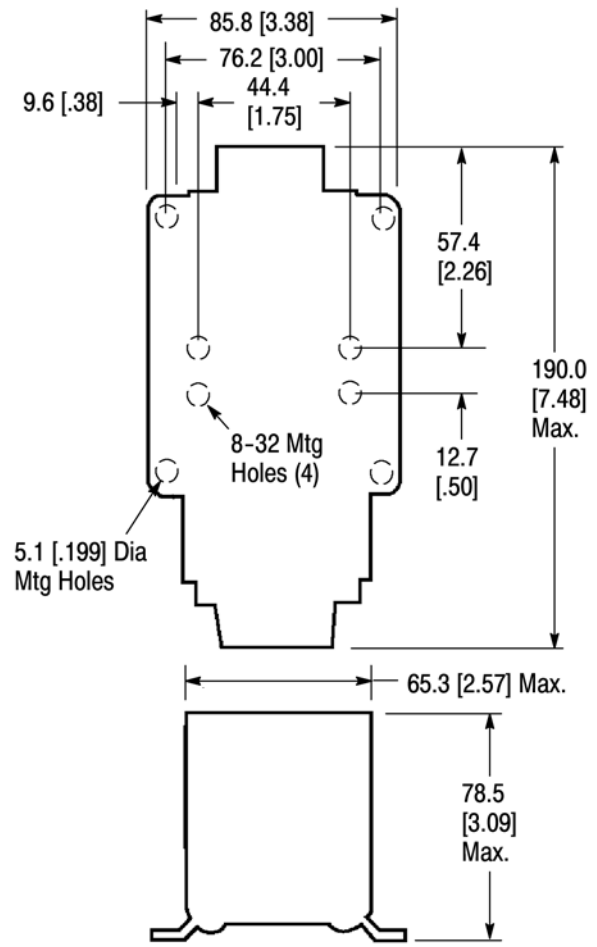
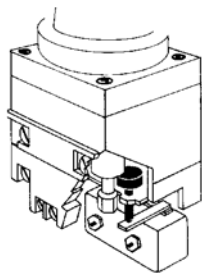
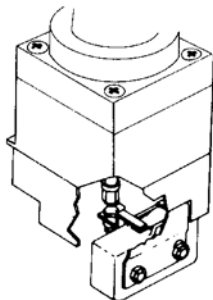

Figure 2



Auxiliary Switch Code L or Code LL



Auxiliary Switch Code T

Figure 3

4.2. Model 7022 Instant Transfer (Code T)

The switch should transfer immediately when relay coil is energized, and should reset shortly before spindle returns to its normal position, following de-energization. The switch transfer is set at the factory.

5. QUALIFICATIONS

The 7000 Series Timing Relays are listed by Underwriters Laboratories Inc. (UL) under File No. E15631. and certified to the Canadian Standards Association (CSA) in File No. LR29186.

6. REVISION SUMMARY

Since the previous version of this document, the following changes were made:

- Removed sentence from Section 2.
- Updated document to corporate requirements.