

RT1710S E-marked Evaluation Board

Purpose

The RT1710S is a type-C E-marked IC. It can request cable current, speed limit and cable type. This document explains the function and use of the RT1710S evaluation board (EVB).

Table of Contents

Purpose	1
Introduction.....	2
Bench Test Setup Conditions	3
Schematic, Bill of Materials & Board Layout	5
More Information.....	7
Important Notice for Richtek Evaluation Board	7

Introduction

General Product Information

The RT1710S is a Type-C cable ID for active and passive cables. All USB Full-Featured Type-C cables shall be electronically marked. Electronically marked cables shall support USB Power Delivery Structured VDM Discover Identity command directed to SOP'. This provides a method to determine the characteristics of the cable, e.g. its current carrying capability, its performance, vendor identification, etc. This may be referred to as the USB Type-C Cable ID function. RT1710S is available in a WDFN-8L 2x2 package.

Product Feature

- Support SOP' and SOP'' Communication
- Integrated Transceiver (BMC PHY)
- Embedded RA Resistor
- Embedded ISO Diode
- Embedded MTP
- Support Multi-Time Writable Memory to Store VDM Data
- Support 4V to 5.5V Operation on VCON1 / VCON2 Pin
- Built-In Slew Rate Control for BMC Signal to Reduce the Effect of EMI
- Support Custom Structured VDM Writing Through CCIN Pin
- Support I²C Bus for Programming VDM Data

Key Performance Summary Table

Key Features	Evaluation Board Number: PCB076_V1
Default Input Voltage	5V
Default Marking & Package Type	RT1710SGQW, WDFN-8L 2x2

Bench Test Setup Conditions

Headers Description and Placement



Carefully inspect all the components used in the EVB according to the following Bill of Materials table, and then make sure all the components are undamaged and correctly installed. If there is any missing or damaged component, which may occur during transportation, please contact our distributors or e-mail us at evb_service@richtek.com.

Test Points

The EVB is provided with the test points and pin names listed in the table below.

Test point/ Pin name	Signal	Comment (expected waveforms or voltage levels on test points)
VCON1	VCONN1 pin	This pin is E-marked power pin. If it is no power, you can measure 1kΩ.
VCON2	VCONN2 pin	This pin is E-marked power pin. If it is no power, you can measure 1kΩ.
GND	Ground	Ground.

Write and read e-marked

RT1710S can write and read to use E-marked writer board (This is other EVB).

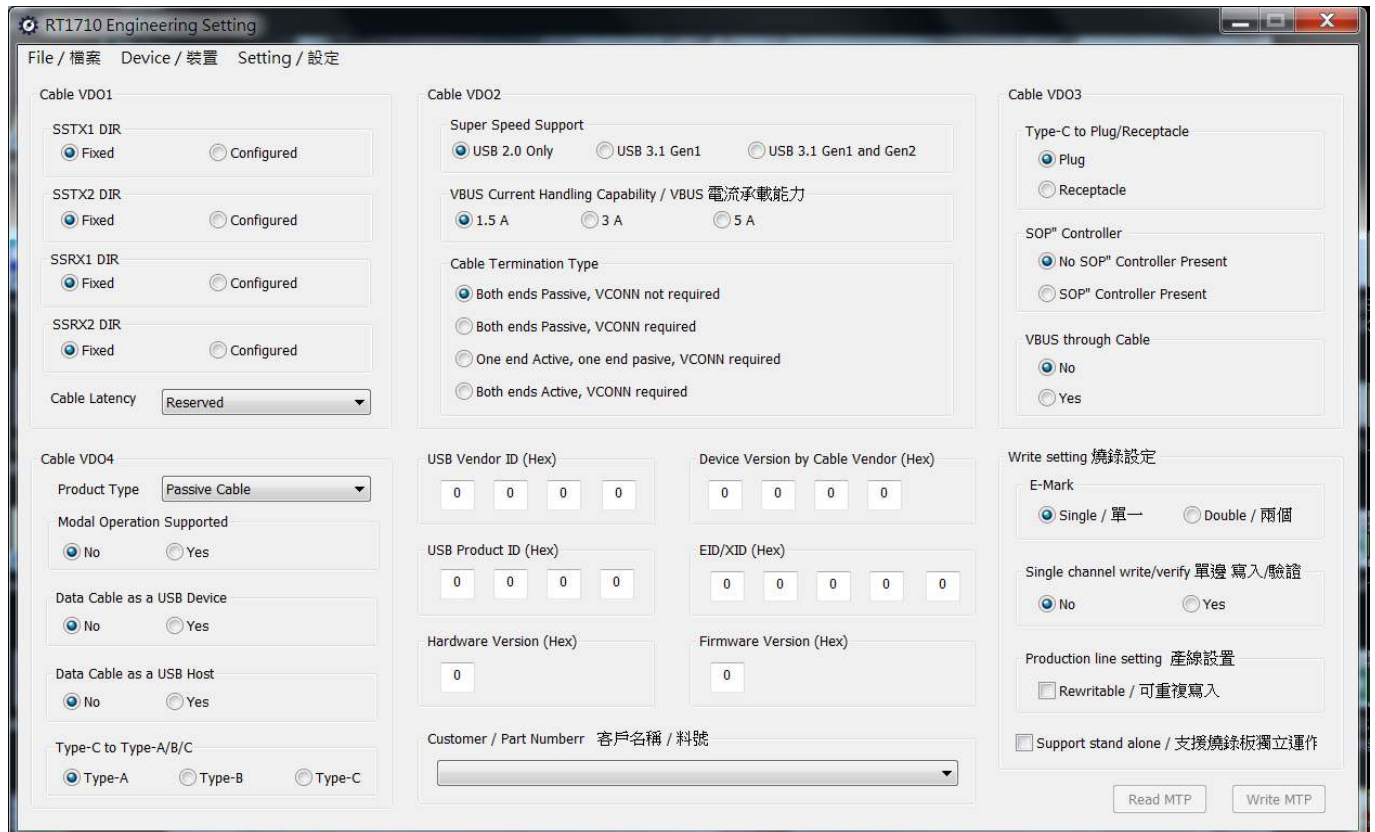

Schematic, Bill of Materials & Board Layout

EVB Schematic Diagram

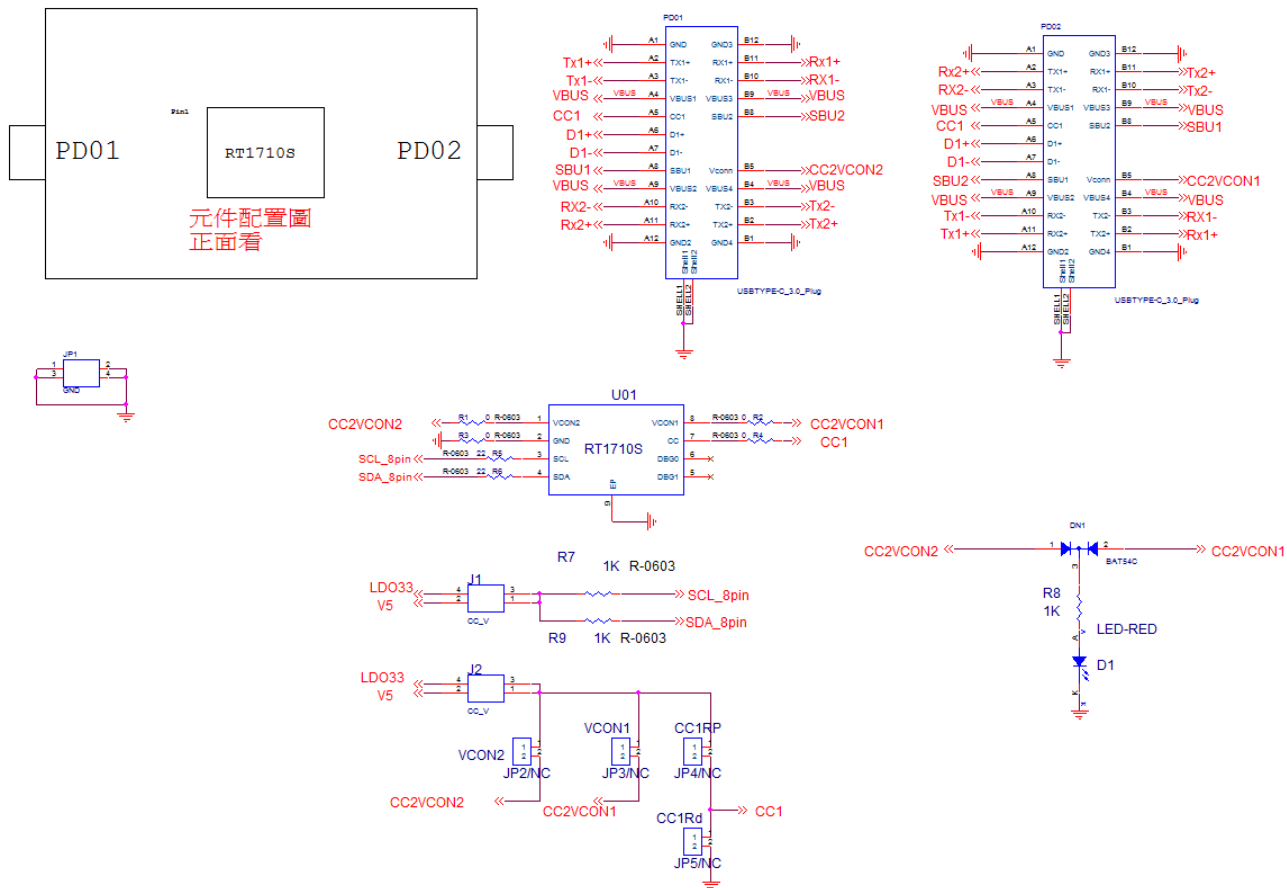

Bill of Materials

Reference	Qty	Part number	Description	Package	Manufacture
U01	1	RT1710SGQW	Cable ID for type-C cables	WDFN2x2-8	Richtek
DN1	1	BAT54C	BAT54C	SOT-23_132	PANJIT
PD01, PD02	2	USBTYPE-C_22P_PLUG	USBTYPE-C	USBTYPE-C_22P_PLUG	JEM
R1, R2, R3, R4	4	WR06X000 PTL	0/0603/±1%	R-0603	WALSIN
R5, R6	2	WR06X22R0FTL	22/0603/±1%	R-0603	WALSIN
R7, R8, R9	3	WR06X1001FTL	1K/0603/±1%	R-0603	WALSIN
D1	1	LNL-302RD000A1	Red LED	RED LED DIP	光楠

PCB Layout

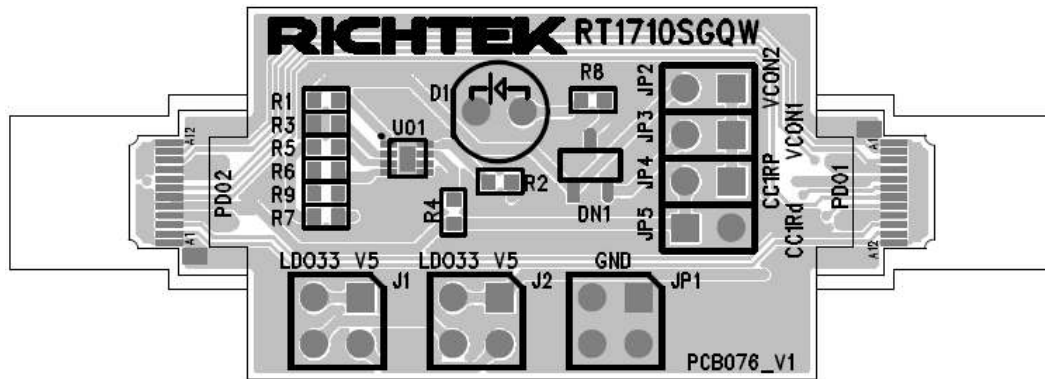

Top View (1st layer)

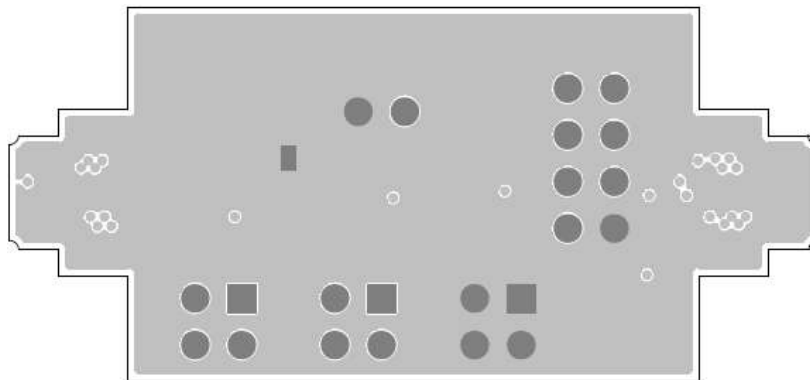

Bottom View (4th Layer)

More Information

For more information, please find the related datasheet or application notes from Richtek website <http://www.richtek.com>.

Important Notice for Richtek Evaluation Board

THIS DOCUMENT IS FOR REFERENCE ONLY, NOTHING CONTAINED IN THIS DOCUMENT SHALL BE CONSTRUED AS RICHTEK'S WARRANTY, EXPRESS OR IMPLIED, UNDER CONTRACT, TORT OR STATUTORY, WITH RESPECT TO THE PRESENTATION HEREIN. IN NO EVENT SHALL RICHTEK BE LIABLE TO BUYER OR USER FOR ANY AND ALL DAMAGES INCLUDING WITHOUT LIMITATION TO DIRECT, INDIRECT, SPECIAL, PUNITIVE OR CONSEQUENTIAL DAMAGES.