

Digital Power Factor Correction IC

Features

- ❑ Digital EMI Noise Shaping
- ❑ Excellent Efficiency Under All Load Conditions
- ❑ Minimal External Devices Required
- ❑ Optimized Digital Loop Compensation
- ❑ Comprehensive Safety Features
 - Undervoltage Lockout (UVLO)
 - Output Overvoltage Protection
 - Input Current Limiting
 - Open/short Loop Protection for IAC & IFB Pins
 - Thermal Shutdown

Applications

- ❑ LCD and LED TVs
- ❑ Monitor Supplies
- ❑ Battery Chargers

Description

The CS1500 is a high-performance power factor correction (PFC) controller for universal AC input, which uses a proprietary digital algorithm for discontinuous conduction mode (DCM) with variable on-time and variable frequency control, ensuring unity power factor.

The CS1500 incorporates all the safety features necessary for robust and compact PFC stages. In addition, it has burst mode control to lower the light-load/standby losses to a minimum. Protection features such as overvoltage, open- and short-circuit protection, and overtemperature help protect the device during abnormal transient conditions.

The digital controller optimizes the system stability and transient performance, simplifies the PFC design, reduces the external component count and BOM costs. The simple design and minimum cost makes CS1500 the ideal choice for PFC up to 300 watts.

Ordering Information

See [page 13](#).

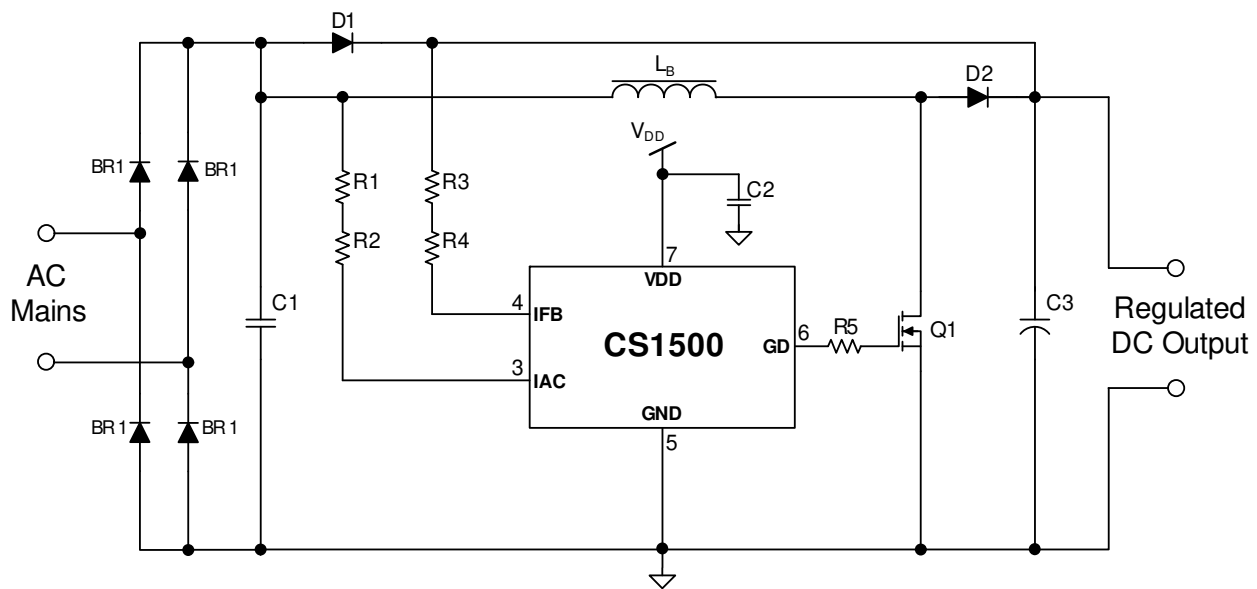

1. INTRODUCTION

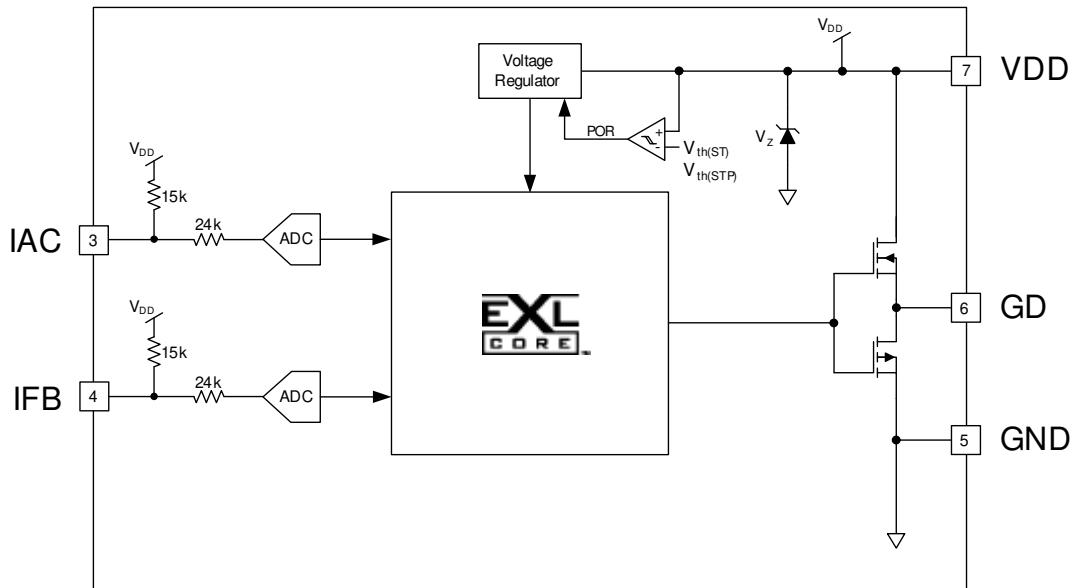

Figure 1. CS1500 Block Diagram

The CS1500 digital power factor controller operates in variable on-time, variable frequency, discontinuous conduction mode (DCM). The CS1500 uses a proprietary digital algorithm to maximize the efficiency and reduce the conductive EMI.

The analog-to-digital converter (ADC) shown in the CS1500 block diagram in Figure 9 is used to sense the PFC output voltage (V_{link}) and the rectified AC line voltage (V_{rect}) by measuring currents through their respective resistors. The magnitudes of these currents are measured as a proportion of a reference current (I_{REF}) that functions as the reference for the ADCs. The digital signal is then processed in a control algorithm which determines the behavior of the CS1500 during start-up, normal operation, and under fault conditions, such as overvoltage, and over-temperature conditions.

The CS1500 PFC switching frequency varies with the V_{rect} on a cycle-by-cycle basis, and its digital algorithm calculates the on-time accordingly for unity power factor. Unlike traditional Critical Conduction Mode (CRM) PFC controller, CS1500 operates at its low switching frequency near the zero-crossing point of the AC input voltage, and it operates at its high switching frequency at the peak of its AC input voltage (this is the opposite of the switching frequency profile for a CRM PFC controller), thus CS1500 reduces switching losses especially under light-load conditions, spreads conducted EMI energy peaks over a wide frequency band and increases overall system efficiency.

The proprietary digital control engine optimizes the feedback error signal using an adaptive control algorithm, improves

system stability and transient response. No external feedback error signal compensation components are required.

The CS1500s digital controller algorithm limits the ON time of the Power MOSFET by the following equation:

$$T_{on} \leq \frac{0.001587V_{\mu S}}{V_{rect}}$$

Where T_{on} is the max time that the power MOSFET is turned on and V_{rect} is the rectified line voltage. In the event of a sudden line surge or sporadic, high dv/dt line voltages, this equation may not limit the ON time appropriately. For this type of line disturbance, additional protection mechanisms such as fusible resistors, fast-blow fuses, or other current-limiting devices are recommended.

Under steady-state conditions, the voltage loop keeps PFC output voltage close to its nominal value. Under light load startup or feedback loop open conditions, the output voltage may pass the overvoltage protection threshold. The digital control engine initiates a fast response loop to shut down gate driving signal to reduce the energy delivered to the output for PFC capacitor protection. When the link voltage drop below $V_{OVP} - V_{OVP(Hy)}$, PFC resumes normal operation.

2. PIN DESCRIPTION

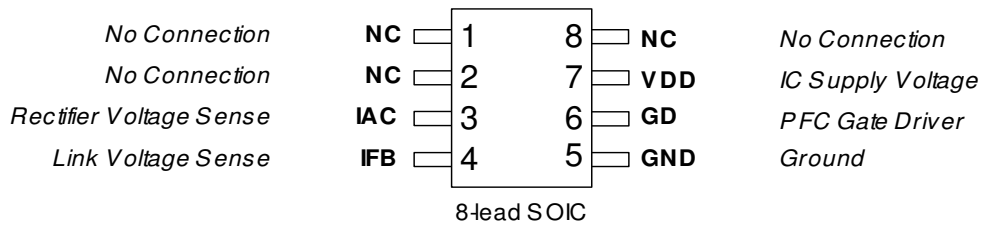

Figure 2. CS1500 Pin Assignments

Table 1. Pin Descriptions

Pin Name	Pin #	I/O	Description
NC	1,2,8	-	NC — No connections
IAC	3	IN	Rectifier Voltage Sense — A current proportional to the rectified line voltage (V_{rect}) is fed into this pin. The current is measured with an A/D converter.
IFB	4	IN	Link Voltage Sense — A current proportional to the output link voltage (V_{link}) of the PFC is fed into this pin. The current is measured with an A/D converter.
GND	5	PWR	Ground — Current return for both the input signal portion of the IC and the gate driver.
GD	6	OUT	Gate Driver Output — The totem pole stage is able to drive the power MOSFET with a peak current of 0.5 A source and 1.0 A sink. The high-level voltage of this pin is clamped at V_Z to avoid excessive gate voltages.
VDD	7	PWR	IC Supply Voltage — Supply voltage of both the input signal portion of the IC and the gate driver.

3. CHARACTERISTICS AND SPECIFICATIONS

3.1 Electrical Characteristics

Typical characteristics conditions:

$$T_A = 25^\circ \text{C}, V_{DD} = 13 \text{V}, \text{GND} = 0 \text{V}$$

All voltages are measured with respect to GND.

Unless otherwise specified, all currents are positive when flowing into the IC.

Minimum/Maximum characteristics conditions:

$$T_J = -40^\circ \text{ to } +125^\circ \text{C}, V_{DD} = 10 \text{V to } 15 \text{V}, \text{GND} = 0 \text{V}$$

Parameter	Condition	Symbol	Min	Typ	Max	Unit
VDD Supply Voltage						
Turn-on Threshold Voltage	V_{DD} Increasing	$V_{DD(on)}$	8.4	8.8	9.3	V
Turn-off Threshold Voltage (UVLO)	V_{DD} Decreasing	$V_{DD(off)}$	7.1	7.4	7.9	V
UVLO Hysteresis		V_{Hys}	-	1.4	-	V
Zener Voltage	$I_{DD} = 20 \text{mA}$	V_Z	17.0	17.9	18.5	V
VDD Supply Current						
Start-up Supply Current	$V_{DD} = V_{DD(on)}$	I_{ST}	-	68	80	μA
Operating Supply Current	$C_L = 1\text{nF}, f_{sw} = 70\text{kHz}$	I_{DD}	-	1.7	1.9	mA
PFC Gate Drive						
Output Source Resistance	$I_{GD} = 100\text{mA}, V_{DD} = 13\text{V}$	R_{OH}	-	9	-	Ω
Output Sink Resistance	$I_{GD} = -200\text{mA}, V_{DD} = 13\text{V}$	R_{OL}	-	6	-	Ω
Rising Time	$C_L = 1\text{nF}, V_{DD} = 13\text{V}$	t_r	-	32	60	ns
Falling Time	$C_L = 1\text{nF}, V_{DD} = 13\text{V}$	t_f	-	15	30	ns
Output Voltage Low State	$I_{GD} = -200\text{mA}, V_{DD} = 13\text{V}$	V_{ol}	-	0.9	1.3	V
Output Voltage High State	$I_{GD} = 100\text{mA}, V_{DD} = 13\text{V}$	V_{oh}	11.3	11.8	-	V
Overvoltage Protection (OVP)²						
Output Voltage at Startup Mode		$V_{O(startup)}$	-	360	-	V
Output Voltage at Normal Mode		$V_{O(nom)}$	-	400	-	V
OVP Threshold		V_{OVP}	-	418	-	V
OVP Hysteresis		$V_{OVP(Hy)}$	-	4	-	V
Thermal Protection¹						
Thermal Shutdown Threshold		T_{SD}	130	143	155	$^\circ\text{C}$
Thermal Shutdown Hysteresis		$T_{SD(Hy)}$	-	9	-	$^\circ\text{C}$

- Notes:
- Specifications guaranteed by design and are characterized and correlated using statistical process methods.
 - Specification are based upon a PFC system configured for AC input of 90-265 VAC (Sine), 45/65 Hz, $V_{link} = 400 \text{V}$, $R_{IAC} = 3.0 \text{M}\Omega$, $R_{IFB} = 3.0 \text{M}\Omega$, $C_3 = 180 \mu\text{F}$, $L_B = 360 \mu\text{H}$, 90 W.
 - Overpower protection is scaled to rated power.
 - Normal operation mode, see [5.2 Start-up vs. Normal Operation Mode](#) on page 8.

3.2 Absolute Maximum Ratings

Pin	Symbol	Parameter	Value	Unit	
7	V _{DD}	IC Supply Voltage	V _Z	V	
1,3,4,5	-	Analog Input Maximum Voltage	-0.5 to V _Z	V	
1,3,4,5	-	Analog Input Maximum Current	50	mA	
7	V _{GD}	Gate Drive Output Voltage	-0.3 to V _Z	V	
7	I _{GD}	Gate Drive Output Current	-1.0 / +0.5	A	
-	P _D	Total Power Dissipation @ T _A =50° C	600	mW	
-	θ _{JA}	Junction-to-Ambient Thermal Impedance	107	°C / W	
-	T _A	Operating Ambient Temperature Range ¹	-40 to +125	°C	
-	T _J	Junction Temperature Operating Range	-40 to +125	°C	
-	T _{Stg}	Storage Temperature Range	-65 to +150	°C	
All Pins	ESD	Electrostatic Discharge Capability	Human Body Model Machine Model Charged Device Model	2000 200 500	V

- Notes: 5. The CS1501 has an internal shunt regulator that controls the voltage on the VDD pin. V_Z, the shunt regulation voltage, can be a maximum of 20 V but may also be as low as 10 V.
6. Long term operation at the maximum junction temperature will result in reduced product life. Derate internal power dissipation at the rate of 50 mW / °C for variation over temperature.

WARNING:

Operation at or beyond these limits may result in permanent damage to the device.
Normal operation is not guaranteed at these extremes.

4. TYPICAL ELECTRICAL PERFORMANCE

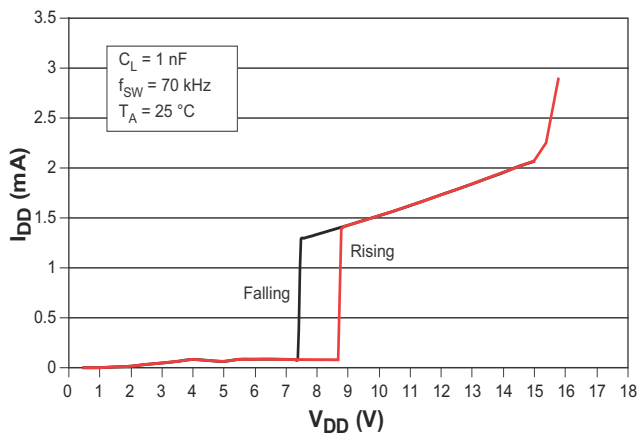

Figure 3. Supply Current vs. Supply Voltage

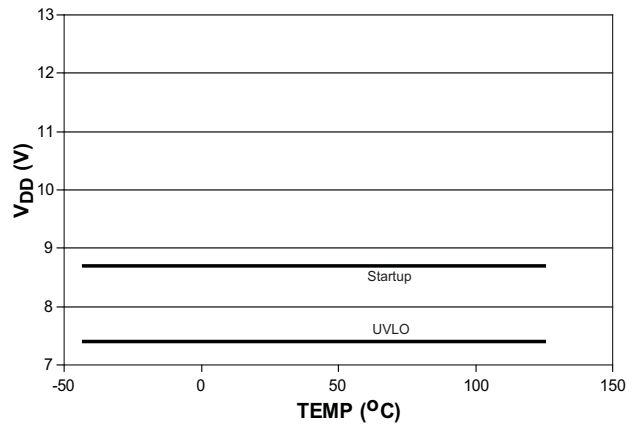

Figure 4. Start-up & UVLO vs. Temp

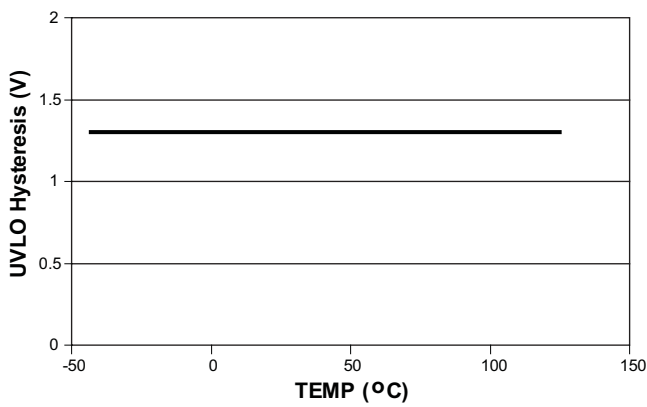

Figure 5. UVLO Hysteresis vs. Temp

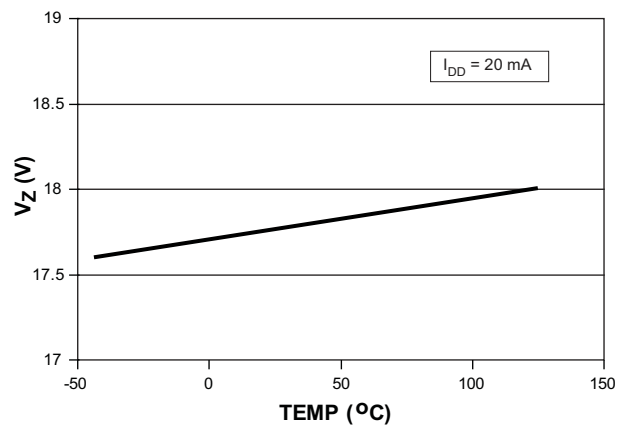
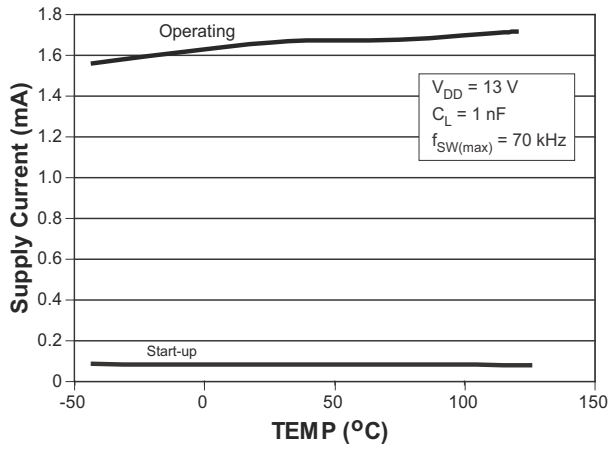
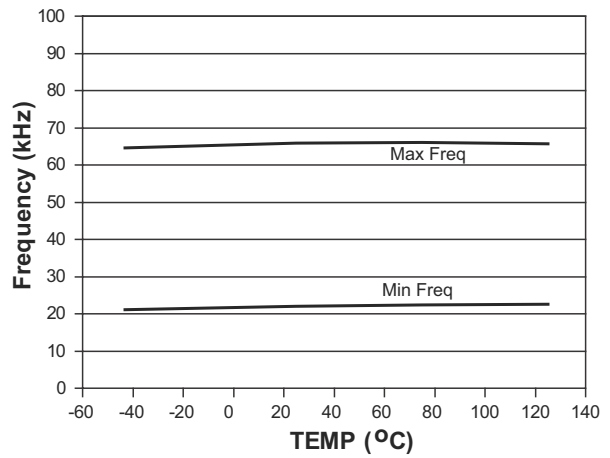
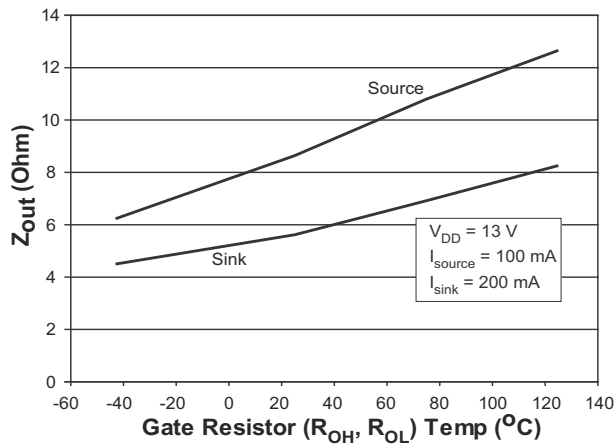
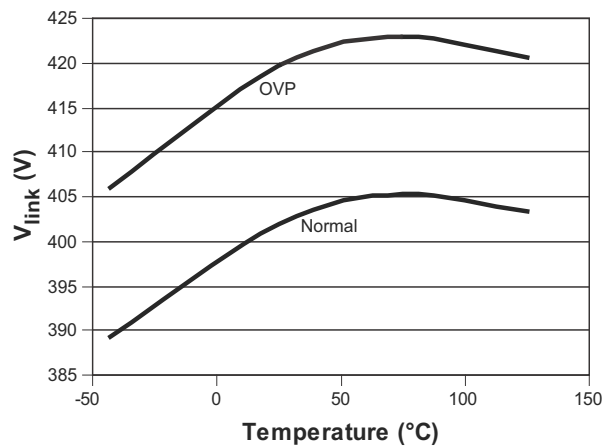

Figure 6. V_DD Zener Voltage vs. Temp

Figure 7. Supply Current (I_{SB} , I_{ST} , I_{DD}) vs. Temp

Figure 8. Min/Max Operating Frequency vs. Temp

Figure 9. Gate Resistance (R_{OH} , R_{OL}) vs. Temp

Figure 10. OVP vs. Temp

5. GENERAL DESCRIPTION

The CS1500 offers numerous features, options, and functional capabilities to the designer of switching power converters. This digital PFC control IC is designed to replace legacy analog PFC controllers with minimal design effort.

5.1 PFC Operation

One key feature of the CS1500 is its operating frequency profile. Figure 11 illustrates how the frequency varies over half cycle of the line voltage in steady-state operation. When power is first applied to the CS1500, it examines the line voltage and adapts its operating frequency to the line voltage as shown in Figure 11. The operating frequency is varied from the peak to the trough of the AC input. During start-up the control algorithm's goal is to generate maximum power while maintaining DCM operation, providing an approximate square-wave envelop current within every half line cycle by adjusting the operating frequency for fast startup behavior.

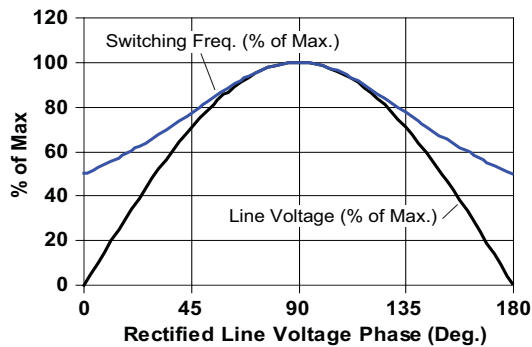

Figure 11. Switching Frequency vs. Phase Angle

Figure 12 illustrates how the operating frequency (as a percentage of maximum frequency) changes with output power and the peak of the line voltage.

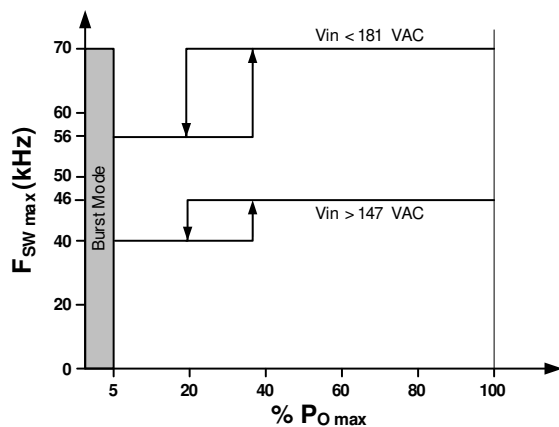

Figure 12. Max Switching Frequency vs. Output Power

When P_o falls below 5% the CS1500 changes to Burst Mode (See 5.3 *Burst Mode* on page 8).

5.2 Start-up vs. Normal Operation Mode

CS1500 has two discrete operation modes: Start-up and Normal. Start-up mode will be activated when V_{link} is less than 90% of nominal value and remains active until V_{link} reaches 100% of nominal value, as shown in Figure 13. Startup mode is activated during initial system power-up. Any V_{link} drop to less than 90% of nominal value, such as load change, can cause the system to enter Start-up mode until V_{link} is brought back into regulation.

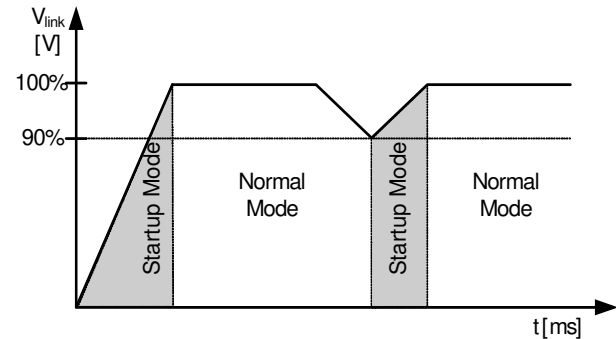

Figure 13. Start-up and Normal Modes

Startup mode is defined as a surge of current delivering maximum power to the output regardless of the load. During every active switch cycle, the 'ON' time is calculated to drive a constant peak current over the entire line cycle. However, the 'OFF' time is calculated based on the DCM/CCM boundary equation.

5.3 Burst Mode

Burst mode is utilized to improve system efficiency when the system output power (P_o) is $< 5\%$ of nominal. Burst mode is implemented by intermittently disabling the PFC over a full half-line period cycle under light load conditions, as shown in Figure 14.

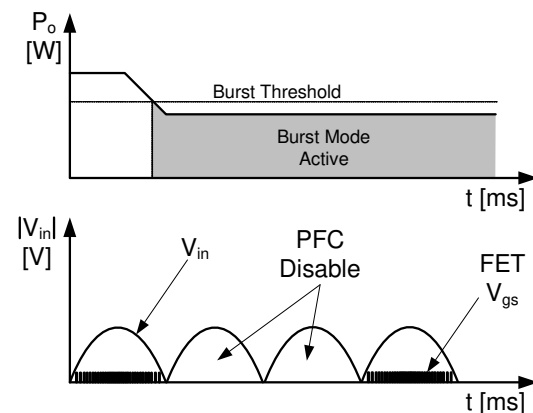

Figure 14. Burst Modes

5.4 Output Power and PFC Boost Inductor

In normal operating mode, the nominal output power is estimated by the following equation.

$$P_o = \alpha \times \eta \times (V_{in(min)})^2 \times \frac{V_{link} - (V_{in(min)} \times \sqrt{2})}{2 \times f_{max} \times L_B \times V_{link}} \quad [\text{Eq.1}]$$

where:

- P_o rated output power of the system
- η efficiency of the boost converter (estimated as 100% by the PFC algorithm)
- $V_{in(min)}$ minimum RMS line voltage is 90V, measured after the rectifier and EMI filter
- V_{link} nominal PFC output voltage must be 400V
- f_{max} maximum switching frequency is 70 kHz
- L_B boost inductor specified by rated power requirement
- α margin factor to guarantee rated output power (P_o) against boost inductor tolerances.

Equation 1 is provided for explanation purposes only. Using substituted required design values for V_{link} and f_{max} gives the following equation.

$$P_o = \alpha \times \eta \times (90V)^2 \times \frac{400V - (90V \times \sqrt{2})}{2 \times 70kHz \times L_B \times 400V} \quad [\text{Eq.2}]$$

Changing values for application-specific devices such as the boost inductor or V_{link} voltage is not recommended and requires changing internal register values.

Solving Equation 2 for the PFC boost inductor L_B gives the following equation.:

$$L_B = \alpha \times \eta \times (90V)^2 \times \frac{400V - (90V \times \sqrt{2})}{2 \times 70kHz \times P_o \times 400V} \quad [\text{Eq.3}]$$

If a value of the boost inductor other than that obtained from Equation 3 above is used, the total output power capability as well as the minimum input voltage threshold will differ according to Equation 2.

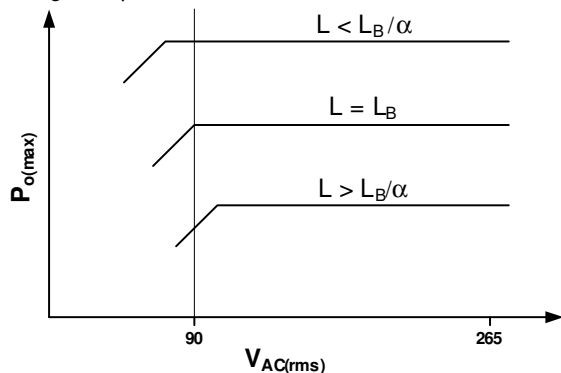

Figure 15. Relative Effects of Varying Boost Inductance

5.5 PFC Output Capacitor

The value of the PFC output capacitor should be chosen based upon voltage ripple and hold-up requirements. To ensure system stability with the digital controller, the recommended value of the capacitor is within the range of 0.5 μF / watt to 2.0 μF / watt.

5.6 Output IFB Sense & Input IAC Sense

A current proportional to the PFC output voltage, V_{link} , is supplied to the IC on pin IFB and is used as a feedback control signal. This current is compared against an internal fixed-value current.

The ADC is used to measure the magnitude of the I_{FB} current through resistor R_{IFB} . The magnitude of the I_{FB} current is then compared to an internal fixed-value current.

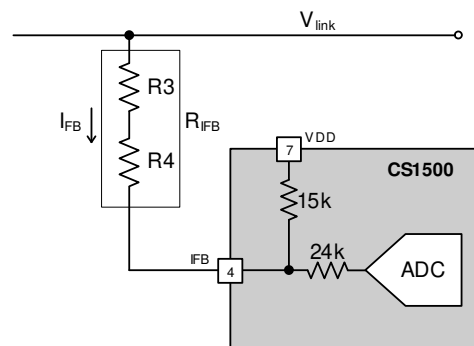

Figure 16. Feedback Input Pin Model

Resistor R_{IFB} sets the feedback current and is calculated as follows:

$$R_{IFB} = \frac{V_{link} - V_{dd}}{I_{fixed}} = \frac{400V - V_{dd}}{129\mu A} \quad [\text{Eq.4}]$$

By using digital loop compensation, the voltage feedback signal does not require an external compensation network.

A current proportional to the AC input voltage is supplied to the IC on pin IAC and is used by the PFC control algorithm.

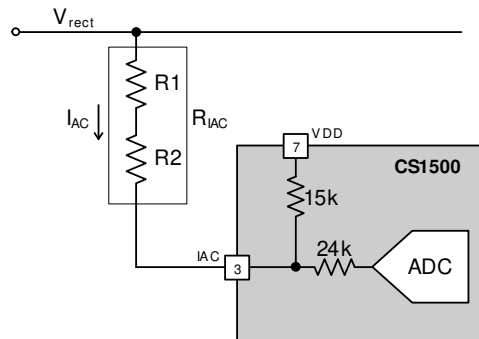

Figure 17. IAC Input Pin Model

Resistor R_{IAC} sets the IAC current and is derived as follows:

$$R_{IAC} = R_{IFB} \quad [\text{Eq.5}]$$

For optimal performance, resistors R_{IAC} & R_{IFB} should use 1% tolerance or better resistors.

5.7 Brownout Protection

As an added protection to the PFC boost stage, the CS1500 includes a failure mechanism that detects high average currents that occur under abnormal brownout conditions. The brownout protection feature monitors the V_{rect} input signal and suspends the gate-drive switching when a brownout threshold breach is detected. Under normal conditions, the CS1500 will never reach the brownout threshold, as the PFC stage is automatically protected by the power limitation of Equation 2, see section 5.4 *Output Power and PFC Boost Inductor* on page 9. In the event that the boost inductor is significantly less than the target value of L_B , the brownout protection threshold may be breached. However, under normal operating conditions with proper boost inductance, this will not occur.

If a brownout event is detected, the CS1500 enters standby, and upon recovery from brownout enters normal operation mode. In order to avoid an erroneous brownout detection, hysteresis and minimum detection time is implemented to avoid brownout detection during input transients. Figure 5.8 illustrates the brownout entry and exit timing. If the input line voltage is lower than the threshold for a fixed period of time, a brownout is declared. The measured voltage decreases at a rate of 5 V / half-line-cycle (~8 ms for 60 Hz line frequency). The CS1500 triggers a timer when the measured voltage falls below the lower brownout threshold. The IC asserts the brownout protection and stops the gate-drive switching only if the timer reaches more than 56 ms, which is determined by the minimum line frequency.

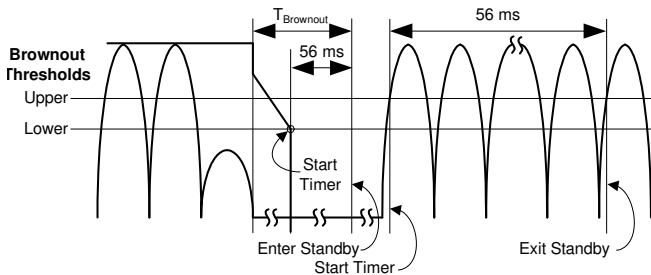

Figure 18. Brownout Sequence

During the brownout state, the device continues monitoring the input line voltage. The device exits the brownout state when the input voltage peak value exceeds the brownout upper threshold for at least 56 ms.

The maximum response time of the brownout protection normally happens at light-load conditions. It can be calculated by the following equation:

$$\begin{aligned}
 T_{\text{Brownout}} &= 8 \text{ ms} + \frac{8 \text{ ms}}{5 \text{ V}}(128 \text{ V} - V_{\text{BP(th)}}) + 56 \text{ ms} \quad [\text{Eq.6}] \\
 &= 8 + \frac{8}{5}(128 - 95) + 56 \\
 &= 116.8 \text{ ms}
 \end{aligned}$$

5.8 Overvoltage Protection

The overvoltage protection (OVP) will trigger immediately and stop the gate drive when the current into the IFB pin (I_{OVP}) exceeds 105% of the reference current value (I_{ref}). The IC resumes gate drive switching when the link voltage drops below $V_{\text{OVP}} - V_{\text{OVP(HY)}}$.

5.9 Open/Short Loop Protection

If the PFC output sense resistor R_{IFB} fails (open or short to GND), the measured output voltage decreases at a slow rate of about 2V / μs , which is determined by ADC sampling rate. The IC stops the gate drive when the measured output voltage is lower than the measured line voltage. The IC resumes gate drive switching when the current into the IFB pin becomes larger than or equal to the current into the IAC pin and V_{link} is greater than the peak of the line voltage ($V_{\text{rect(pk)}}$). The maximum response time of open/short loop protection for R_{IFB} is about 150 μs in the CS1500.

If the PFC input sense resistor R_{IAC} fails (open or short to GND), the current reference signal supplied to the IC on pin IAC falls to zero.

6. SUMMARY OF EQUATIONS

Eq. #	Equation	Variables/Recommended Values
1	Output Power (page 9) $P_o = \alpha \times \eta \times (V_{in(min)})^2 \times \frac{V_{link} - (V_{in(min)} \times \sqrt{2})}{2 \times f_{max} \times L_B \times V_{link}}$	P_o rated output power of the system η efficiency of the boost converter (estimated as 100% by the PFC algorithm)
2	Output Power w/ required values (page 9) $P_o = \alpha \times \eta \times (V_{in(min)})^2 \times \frac{400V - (V_{in(min)} \times \sqrt{2})}{2 \times 70kHz \times L_B \times 400V}$	$V_{in(min)}$ minimum RMS line voltage is 90V, measured after the rectifier and EMI filter V_{link} nominal PFC output voltage must be 400 V f_{max} maximum switching frequency is 70 kHz L_B boost inductor specified by rated power requirement
3	Boost Inductor (page 9) $L_B = \alpha \times \eta \times (V_{in(min)})^2 \times \frac{400V - (V_{in(min)} \times \sqrt{2})}{2 \times 70kHz \times P_o \times 400V}$	α margin factor to guarantee rated output power (P_o) against boost inductor tolerances.
4	Output IFB Sense Resistor (page 9) $R_{IFB} = \frac{V_{link} - V_{dd}}{I_{fixed}} = \frac{400V - V_{dd}}{129\mu A}$	
5	Input IAC Sense Resistor (page 9) $R_{IAC} = R_{IFB}$	
6	Boost Inductor Peak Current $I_{LB(pk)} = \frac{4 \times P_o}{\eta \times V_{in(min)} \times \sqrt{2}}$	
7	Boost Inductor RMS Current $I_{LB(rms)} = \frac{P_o}{V_{in(min)} \times \eta}$	
8	V_{link} Voltage Ripple $\Delta V_{link(rip)} = \frac{P_o}{2\pi \times f_{line(min)} \times 400 \times C_{out}}$	C_{out} Value of the output capacitor in microfarads. $f_{line(min)}$ Minimum line frequency.

7. SUMMARY OF TERMS

Variable	Definition
η	The efficiency factor.
α	A margin factor to guarantee rated power against tolerances and transients.
$f_{\text{line(min)}}$	The minimum AC line frequency.
I_{AC}	The current generated by V_{rect} that flows into the IAC pin.
I_{FB}	The current generated by V_{link} that flows into the IFB pin.
$I_{\text{FET(pk)}}$	The PFC MOSFET peak current, which is equal to the peak current in the PFC boost inductor.
I_{rms}	The magnitude of the RMS current.
I_{sat}	The boost inductor L_{B} saturation current.
I_{st}	The sum of the current into the IAC and IFB pins.
I_{ST}	The startup current of the chip.
L_{B}	The PFC boost inductor.
P_{o}	The nominal output power from the CS1500 PFC circuit.
$P_{\text{o(max)}}$	The maximum value of the output power from the CS1500 PFC circuit.
R_{IAC}	The sense resistor used to measure current into the IAC pin.
R_{IFB}	The sense resistor used to measure current into the IFB pin.
$V_{\text{in(min)}}$	The minimum specified line voltage for proper operation (volts RMS).
V_{link}	The magnitude of the output voltage from the PFC.
$V_{\text{link(min)}}$	The magnitude of the output voltage from the PFC.
$\Delta V_{\text{link(rip)}}$	$\Delta V_{\text{link(rip)}}$, is the output voltage ripple requirement in volts peak-to-peak
V_{rect}	The instantaneous value of the rectified line voltage (volts).

8. PACKAGE DRAWING

8L SOIC (150 MIL BODY) PACKAGE DRAWING

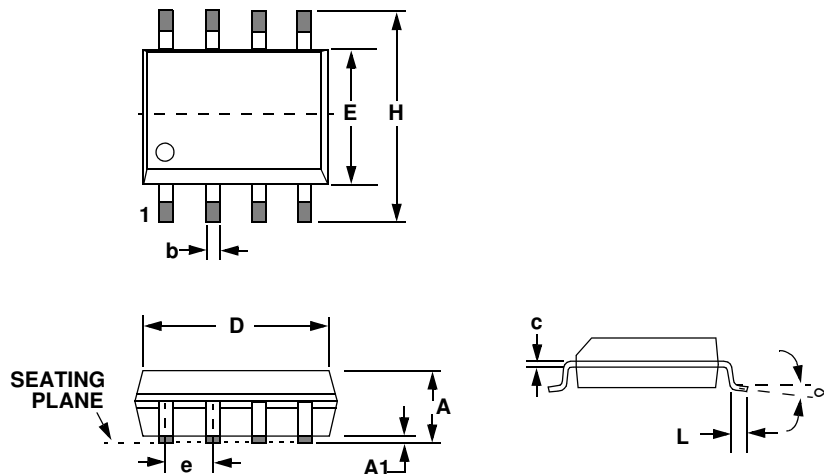

DIM	INCHES		MILLIMETERS	
	MIN	MAX	MIN	MAX
A	0.053	0.069	1.35	1.75
A1	0.004	0.010	0.10	0.25
B	0.013	0.020	0.33	0.51
C	0.007	0.010	0.19	0.25
D	0.189	0.197	4.80	5.00
E	0.150	0.157	3.80	4.00
e	0.040	0.060	1.02	1.52
H	0.228	0.244	5.80	6.20
L	0.016	0.050	0.40	1.27
∞	0°	8°	0°	8°

JEDEC # MS-012

9. ORDERING INFORMATION

Part #	Temperature Range	Package Description
CS1500-FSZ	-40 °C to +125 °C	8-lead SOIC, Lead (Pb) Free

10. ENVIRONMENTAL, MANUFACTURING, & HANDLING INFORMATION

Model Number	Peak Reflow Temp	MSL Rating ^a	Max Floor Life ^b
CS1500-FSZ	260 °C	2	365 Days

a. MSL (Moisture Sensitivity Level) as specified by IPC/JEDEC J-STD-020.

b. Stored at 30 °C, 60% relative humidity.

11. REVISION HISTORY

Revision	Date	Changes
A7	JUL 2010	Initial public advance data release.
F1	NOV 2010	Revised Brownout section. Finalized data sheet for QPL 1.

Contacting Cirrus Logic Support

For all product questions and inquiries contact a Cirrus Logic Sales Representative.
To find one nearest you go to <http://www.cirrus.com>

IMPORTANT NOTICE

Cirrus Logic, Inc. and its subsidiaries ("Cirrus") believe that the information contained in this document is accurate and reliable. However, the information is subject to change without notice and is provided "AS IS" without warranty of any kind (express or implied). Customers are advised to obtain the latest version of relevant information to verify, before placing orders, that information being relied on is current and complete. All products are sold subject to the terms and conditions of sale supplied at the time of order acknowledgment, including those pertaining to warranty, indemnification, and limitation of liability. No responsibility is assumed by Cirrus for the use of this information, including use of this information as the basis for manufacture or sale of any items, or for infringement of patents or other rights of third parties. This document is the property of Cirrus and by furnishing this information, Cirrus grants no license, express or implied under any patents, mask work rights, copyrights, trademarks, trade secrets or other intellectual property rights. Cirrus owns the copyrights associated with the information contained herein and gives consent for copies to be made of the information only for use within your organization with respect to Cirrus integrated circuits or other products of Cirrus. This consent does not extend to other copying such as copying for general distribution, advertising or promotional purposes, or for creating any work for resale.

CERTAIN APPLICATIONS USING SEMICONDUCTOR PRODUCTS MAY INVOLVE POTENTIAL RISKS OF DEATH, PERSONAL INJURY, OR SEVERE PROPERTY OR ENVIRONMENTAL DAMAGE ("CRITICAL APPLICATIONS"). CIRRUS PRODUCTS ARE NOT DESIGNED, AUTHORIZED OR WARRANTED FOR USE IN PRODUCTS SURGICALLY IMPLANTED INTO THE BODY, AUTOMOTIVE SAFETY OR SECURITY DEVICES, LIFE SUPPORT PRODUCTS OR OTHER CRITICAL APPLICATIONS. INCLUSION OF CIRRUS PRODUCTS IN SUCH APPLICATIONS IS UNDERSTOOD TO BE FULLY AT THE CUSTOMER'S RISK AND CIRRUS DISCLAIMS AND MAKES NO WARRANTY, EXPRESS, STATUTORY OR IMPLIED, INCLUDING THE IMPLIED WARRANTIES OF MERCHANTABILITY AND FITNESS FOR PARTICULAR PURPOSE, WITH REGARD TO ANY CIRRUS PRODUCT THAT IS USED IN SUCH A MANNER. IF THE CUSTOMER OR CUSTOMER'S CUSTOMER USES OR PERMITS THE USE OF CIRRUS PRODUCTS IN CRITICAL APPLICATIONS, CUSTOMER AGREES, BY SUCH USE, TO FULLY INDEMNIFY CIRRUS, ITS OFFICERS, DIRECTORS, EMPLOYEES, DISTRIBUTORS AND OTHER AGENTS FROM ANY AND ALL LIABILITY, INCLUDING ATTORNEYS' FEES AND COSTS, THAT MAY RESULT FROM OR ARISE IN CONNECTION WITH THESE USES.

Cirrus Logic, Cirrus, the Cirrus Logic logo designs, EXL CORE, and the EXL CORE logo designs are trademarks of Cirrus Logic, Inc. All other brand and product names in this document may be trademarks or service marks of their respective owners.